

GRAM



Operating- and servicemanual Gram Eco / Superior



Content

MPC 46 and the menus.	3
When servicing the product.	4
Start-up sequence	4
Defrosting	7
Temperature control and regulation:	7
Keylock	8
Error codes	8
User menu	9
Visual and acoustic settings	11
Settings for running cycle	12
Test program for relays and electrical components	14
Display of current sensor inputs	15
Reset the controller to factory setting	15
Parameter settings in commercial program variants	16
Changing door hinge side.	17
Plug connections onboard the controller	20

MPC 46 and the menus.

The menus are divided up in two main menus.

A menu for presentations of values in the display and settings for alarms parameters, and another menu for technical, practical or physical settings to a normal refrigerator or freezer.

In each main menu there exist smaller submenus. These submenus are divided up in specific menu for kind of cycles as defrosting or the settings for running the evaporator fan.

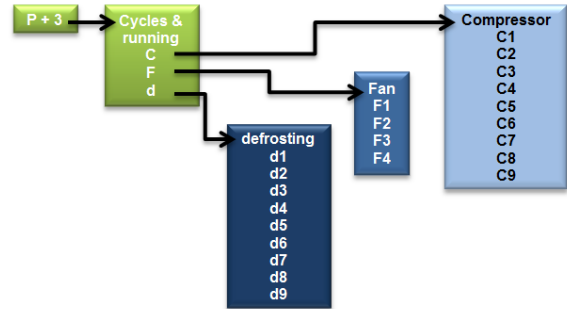



When servicing the product.

Make sure the appliance is switched off at the socket before service is performed on electrical parts. It is not sufficient to switch off the cabinet by the START/STOP key as there will still be voltage to some electrical parts of the cabinet.

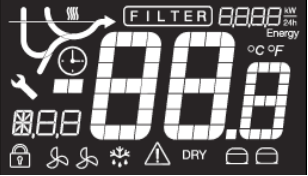
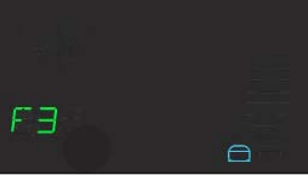

Start-up sequence

When the product switches ON, the software is loaded into the MPC-46. The display shows multiple informations, see below:

Text	Display
<p>Second 0-3: Software is loaded into MPC-46 on start-up</p>	 <p>All segments light up white. Control, is everything ok? The display has recognized <u>version 3.0</u> and awaits more information...</p>
<p>Approx. 3rd second and 3-4 seconds forward:</p>	 <p>Now the Maxi display recognizes programme variant F3+ version 3.0. The display recognizes that the product is equipped with one compressor.</p>
<p>Approx. 7th second and 3-4 seconds forward:</p>	 <p>The display recognizes which control lamps are needed according to the programme variant F3+, and the appropriate lamps are lit. The version number is displayed.</p>
<p>Approx. 10th second and 3-4 seconds forward:</p>	 <p>All control lamps are turned off, except the compressor lamp. The large display is displayed ready for use.</p>

Start up after power on – hot product.

On hot products or if the product has just been unpacked and connected to mains power, the temperature is so high that the defrosting cycle is cancelled, and refrigeration starts immediately.



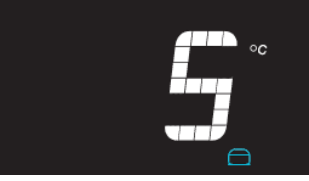
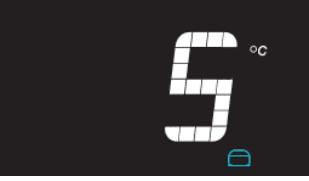
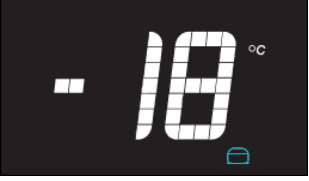

Because the product has not been running before, the setpoint is displayed and not the current temperature.

Text	Display
<p>Normal operation after start-up phase has ended</p>	 <p>Only +5 °C is displayed, which is the standard setpoint for a refrigerator.</p>
<p>Situation 1: Refrigerator</p> <p>Less than a second later compressor starts.</p>	 <p>The compressor starts. The color is cyan, and lights constantly.</p>
<p>Situation 2: Extended refrigerator</p> <p>Less than a second later compressor starts.</p>	 <p>The compressor starts. The color is cyan, and lights constantly.</p>
<p>Situation 3: Freezer</p> <p>Less than a second later compressor starts.</p>	 <p>Standard setpoint for a freezer is -18 °C. The compressor starts. The color is cyan, and lights constantly.</p>

Start up after power on – cold product.

On cold products, or if the product has been turned off for a short while, and the evaporator temperature is still below the freezing point, a defrosting cycle will be activated, and refrigeration starts later.

Because the product has not been running before, the setpoint is displayed and not the current temperature.



Tekst	Maxi Display
<p>Normal operation after start-up phase has ended</p>	 <p>Only +5 °C is displayed, which is the standard setpoint for a refrigerator.</p>
<p>Situation 1: Refrigerator</p> <p>Less than a second later, defrosting starts, and uses the evaporator fan for the defrosting process.</p>	 <p>Because defrosting is running, but with evaorator fan, both control lamps are lit.</p> <p>Defrost mode: Air (Evaporator fan running 100 %)</p>
<p>Situation 2: Extended refrigerator</p> <p>Less than a second later, defrosting starts, and uses the evaporator fan for the defrosting process.</p>	 <p>Because defrosting is running, but with evaorator fan, both control lamps are lit.</p> <p>Defrost mode: Automatic (Controller selects acc. to setpoint whether fan or electrical heater is to be used.) If electrical defrosting is selected, the control lamp for fan will not light up</p>
<p>Situation 3: Freezer</p> <p>Less than a second later, defrosting starts, and uses the electrical heater.</p>	 <p>Defrost mode: Electrical (Heater below evaporator)</p>



Defrosting

The defrosting cycle runs 4 times each day. If the cabinet is operating under severe load (frequent door opening and frequent replenishment) manual defrosting can become necessary.

To start manual defrosting: Push  +  for more than 3 seconds.

Refrigerator: Control lamps for fan  and defrosting  light up.







Extended refrigerator: Control lamp for defrosting  light up, and lamp for fan  light up depending on setpoint.

Freezer: Control lamp for defrosting  light up.

Shortly after defrosting has ended, the compressor starts, and the compressor symbol  lights blue.



The number defrosts can be changed. See chapter "User menu".

Temperature control and regulation:

- Keep  pressed. When doing this, the setpoint temperature is displayed. While  is kept pressed, the setpoint can be changed by pressing  or .
- Each time  or  is pressed the temperature will change one degree. The new value flashes in the display
- When the required setpoint has been set, let go of the keys, a short beep sounds, and the settings are saved.







Keylock

The keypad can be locked by simultaneously pushing  +  for more than 5 seconds.

 lights to indicate that the keys are locked, and a short beep sounds. Now it is not possible to use the keys for temperature setting etc.

The same code is to be used for unlocking the keypad again.

Error codes

- OP** The door is open. The alarm system is activated, if the door is not closed within a certain time. The user is reminded that the door is not properly closed.
- F1**  Cabinet sensor error. In the meantime the cabinet itself will maintain the set temperature by the memory of the controller. Service assistance is required.
- F2**  Evaporator sensor error.
The cabinet will keep running until the error has been mended. Service assistance is required.
- F3/F4**  Condenser sensor error. The cabinet will keep running, until the error has been mended. Service assistance is required.
Applies only to cabinets with built-in compressor.
- F7**  Indicates that the condenser temperature is too high. The cause might be a clogged condenser, or too high ambient temperature.
If the condenser or air filter needs cleaning, the cabinet must be disconnected at the mains power. Cleaning of the condenser is done with a brush or a vacuum cleaner.
The air filter can be removed and cleaned in a dishwasher at max. 50°C.
If the ambient temperature is too high, the placement of the cabinet might be wrong, and an alternative place should be found. Ventilation might help.
If this does not help, request service assistance.
Applies only to cabinets with built-in compressor.



User menu

Push on **P** and **1** buttons at the same time in more than 3 sec. and the first Setup menu appears in the display.

With **+** and **-** buttons its possible to look through each menu items in the "User menu". Push on **P** button to activate the desired item and adjust the setting with **+** and **-** buttons.

To confirm the new setting, push **P** button. Leave the menu item and user menu with the **0** button.

Menu access P+1 →	↓	→		
Dry refrigeration	DC			Activation of dry refrigeration. [ON/OFF]
Rapid thaw	UF			Activation of rapid thaw. [ON/OFF]
Local alarm setting	LAL	LHL	[° C]	Setting the upper alarm limit. At alarm, the display shows: [A2].
		LLL	[° C]	Setting the lower alarm limit. At alarm, the display shows: [A3].
		Lhd	[min.]	Time delay for the upper alarm limit.
		LLd	[min.]	Time delay for the lower alarm limit.
		DA	On/off	Activation of local door alarm. At alarm, the display shows: [A1]. [on/off]
		DAd	[min.]	Time delay for the door alarm.
		BU	On/off	Activation of buzzer. The buzzer sounds at alarms [A1], [A2], [A3]. [1=on / 0=off]
External alarm setting	EAL	EhL	[° C]	Setting the upper alarm limit At alarm, the display shows: [A4].
		ELL	[° C]	Setting the lower alarm limit . At alarm, the display shows: [A5].
		Ehd	[min.]	Time delay for upper alarm.
		ELd	[min.]	Time delay for lower alarm.
		DA	On/off	Activation of local door alarm. At alarm, the display shows: [A1]. [on/off]
		DAd	[min.]	Time delay for the door alarm.
		BU	On/off	Activation of buzzer. The buzzer sounds at alarms [A1], [A4], [A5]. [1=on / 0=off]
	ALL			Activation of escorting alarm limits. [FAS]= fixed limits / [ESC] = limits following the setpoint.
	DEF			Number of defrosts in 24 hours.

User menu overview:

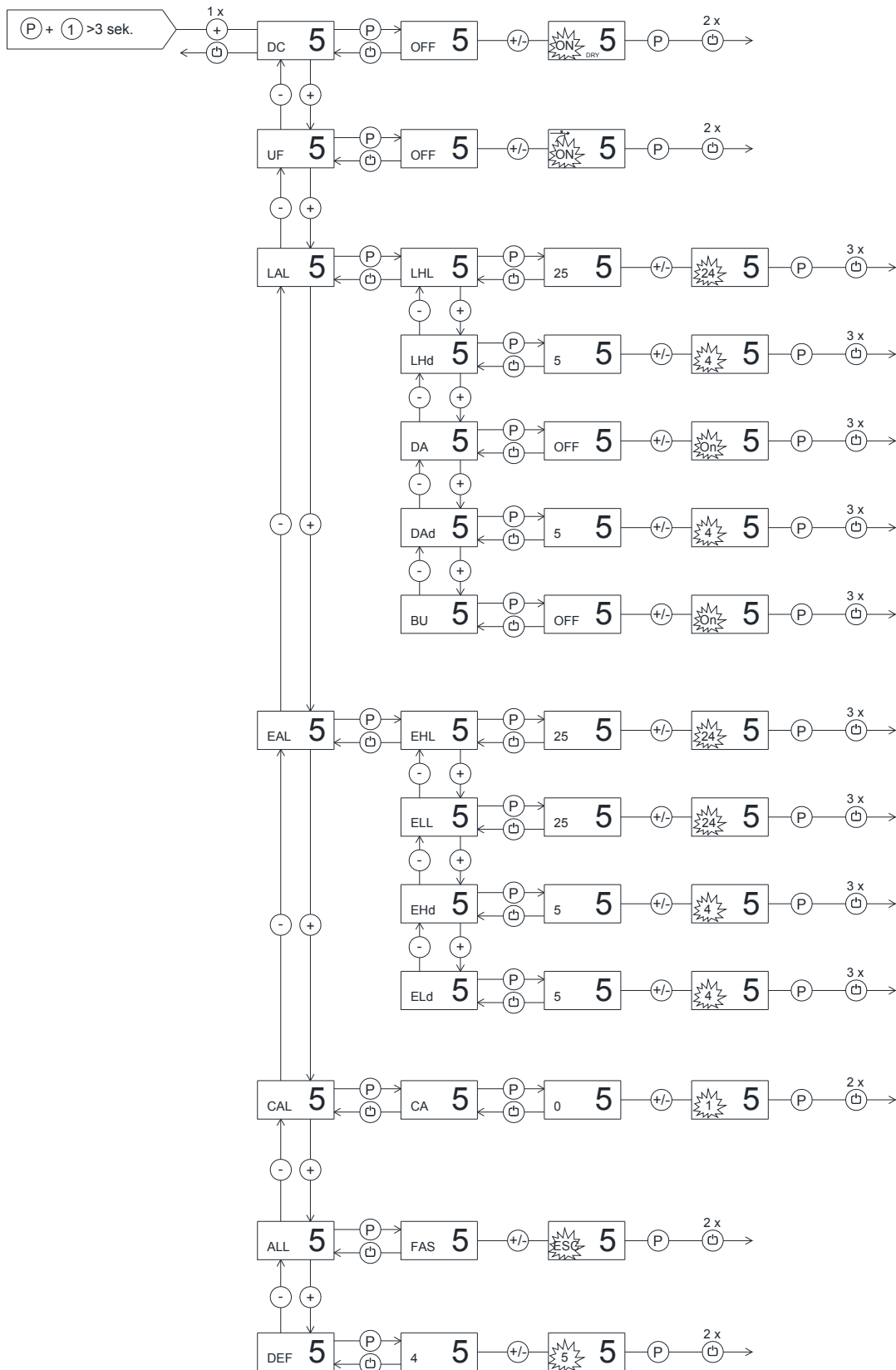

Visual and acoustic settings

Push on **P** and **2** buttons at the same time in more than 6 sec. and the menu item [**A**] appears in the display.

With **+** and **-** buttons it's possible to look through the main menu item [**A**] and [**P**]. Push on **P** button to enter the submenu from the main menu items.

With **+** and **-** buttons it's possible to look through the submenus menu items. Push on **P** button to enter the desired menu item and adjust the setting with **+** and **-** buttons.

To confirm the new setting, push **P** button. Leave the menu item and submenu with the **⏪** button.

Menu access P+2	↓	→		
Alarm setup	A	A1	[° C]	In case of condenser overhear, compressor protection cycle is started.
		A2	[° C]	Condenser temperature, which disconnects the compressor protection cycle.
		A3	[min.]	Re-enter time for acoustic alarm (min.)
Display presentation	P	P1	[min.]	Temperature freeze after defrosting end.
		P2	[° K]	Temperature freeze around setpoint. Temperature fluctuation filter.
		P3	[sec.]	Display updating frequency.
		P4		Selection of Celsius or Fahrenheit temperature scale.

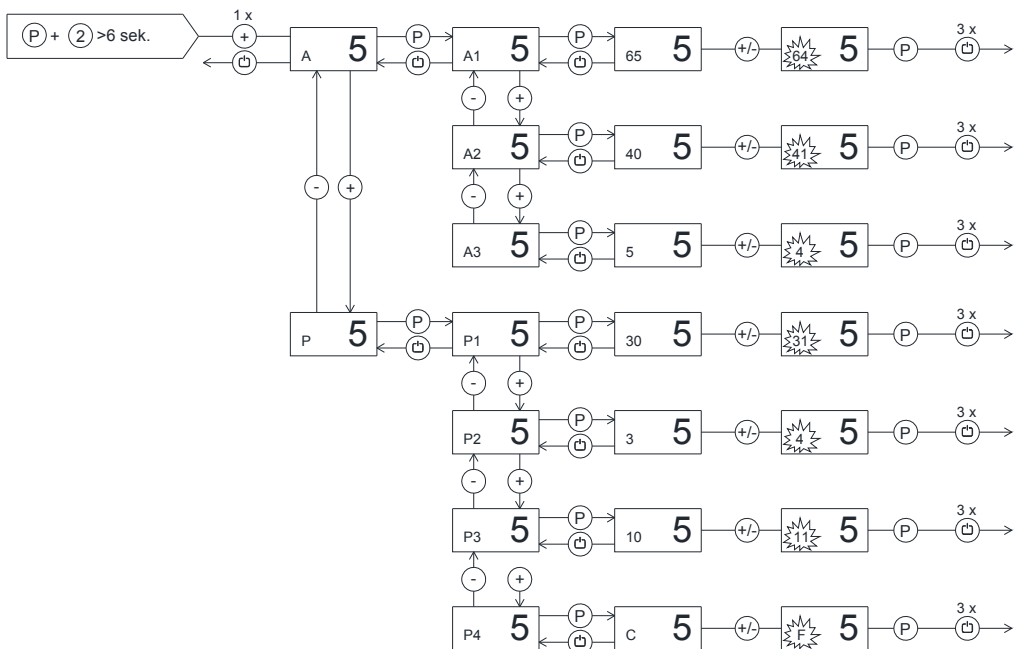



Settings for running cycle

Push on **P** and **3** buttons at the same time in more than 6 sec. and the menu item [**C**] appears in the display.

With **+** and **-** buttons it's possible to look through the main menu item [**C**], [**F**] and [**d**]. Push on **P** button to enter the submenu from the main menu items.

With **+** and **-** buttons it's possible to look through the submenus menu items. Push on **P** button to enter the desired menu item and adjust the setting with **+** and **-** buttons.

To confirm the new setting, push **P** button. Leave the submenu and main menu item with the **3** button..

Menu access P+3 →1	↓	→1		
Compressor setup	C	C1	[° K]	Differential for compressor cut-in and cut-out.
		C2	[° C]	Highest allowed temperature limit for the cabinet.
		C3	[° C]	Lowest allowed temperature limit for the cabinet.
		C4	[min]	Forced pause time for compressor between cut-out and cut-in.
		C5		Number of condenser sensors connected.
		C6	[min]	Compressor stop by open door.
		C7	[° K]	Soft differential for cool/heat cut-out (kelvin)
		C8	[° C]	Setpoint for condenser fan
		C9	[° K]	Cut-out differential for condenser fan (kelvin)
Evaporator fan	F	F1	[° C]	Temperature allowing the evaporator fan to start after defrosting.
		F2	[min.]	Pause time of evaporator fan, while the compressor is stopped.
		F3	[sek.]	Running time of evaporator fan, while the compressor is stopped.
		F4	[° K]	Stop temp. of LT compressor i cascade evaporator (celcius)
Display presentation	D	D1		Number of defrosts / 24h
		D2	[° C]	Defrost stop temperature measured at the evaporator.
		D3	On/off	Activation of defrost by start-up sequence [1=on / 0=off].
		D4	[min.]	Maximum defrosting time.
		D5		Selection between automatic- [1], air- [2] or electric defrosting [3].
		D6	[min.]	Dripping time after defrosting
		D7	[° C]	Temperature limit deciding the defrosting method, when d5 = [1]
		D8	[° C]	Evaporator temperature starting an extra defrosting cycle.

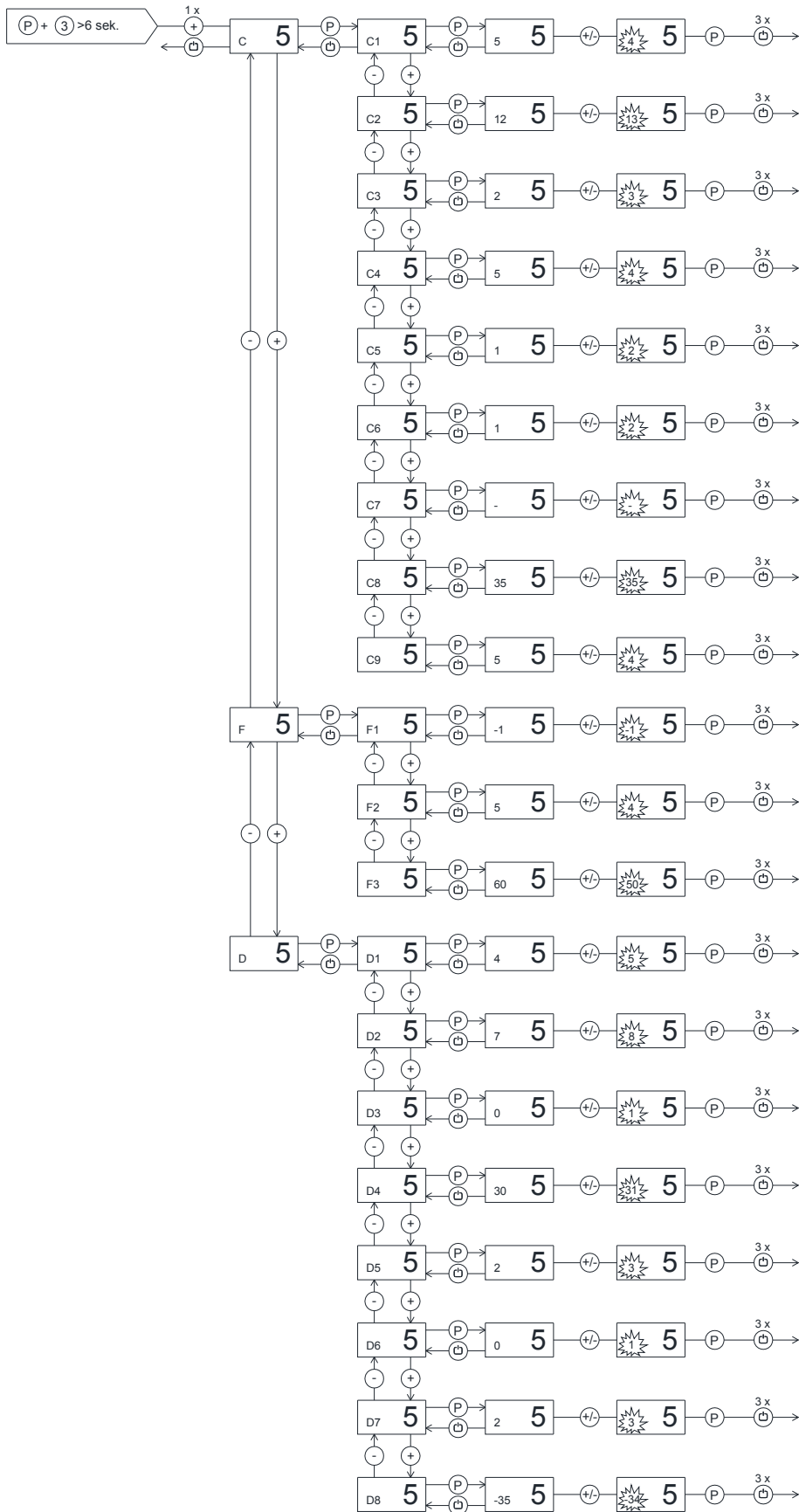

Test program for relays and electrical components

Push on **P** and **4** buttons at the same time for more than 6 sec. and the menu item [**tC**] appears in the display.

Note: When this test program is started, all outputs are de-activated, which means the cabinet is turned off. It might be experienced that the compressor does not start again after leaving the program, because the compressor protection "forced pause" takes effect.

With **+** and **-** buttons its possible to look through each menu items in the "Service program". Push on **P** button to activate the desired relay and the display glows with [**on**]. The desired relay conducts now power to the electrical component.

Push the **☐** button to switch off the power from the electrical component. Leave the service program with the **☐** button.

Menu access P+4 →	↓	P-key → [on]
Compressor	TC	Compressor is running, and if a condenser fan is present, it runs too.
Evaporator fan	TF	Evaporator fan is running
Defrost heater	Td	Defrost heater is turned on. Warning: the heater might be very hot. Danger of burn!
Light	TL	Light is switched on.
Alarm output	TA	Activation of voltage free contact. Alarm output.
Display test	TdP	All LED's light up for 1 sec. and the buzzer sounds. Then the software revision number is displayed.

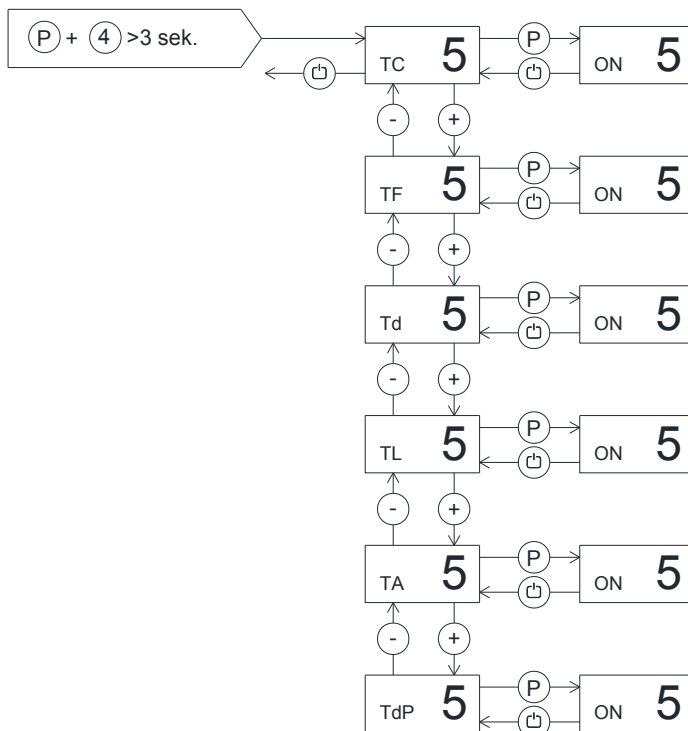

Display of current sensor inputs

Push on **P** and **5** buttons at the same time in more than 6 sec. and the menu item [**P-A**] appears in the display.

With **+** and **-** buttons its possible to look through each menu items to check each sensor in the cabinet. Push on **P** button to activate the actual sensor and the display shows the actual temperature. Leave the program with the **⏪** button.

Menu access P+5 →1	↓	P-key → [° C]	Display message and cause	
Room sensor	P-A	Room sensor measurement is displayed	F1	Room sensor error
Evaporator sensor	P-b	Evaporator sensor measurement is displayed	F2	Evap.sensor error
Condenser sensor 1	P-C	Condenser sensor 1 measurement is displayed	F3	Condenser sensor 1 error
Condenser sensor 2	P-d	Condenser sensor 1 measurement is displayed	F4	Condenser sensor 2 error
*			F7	Overheated condenser 1 and 2
An overheated condenser could be caused by a clogged air filter. Can be triggered by both C and d sensor.			-0-	Open door symbol
By open door this symbol is displayed. In event of a too long door opening, an alarm is triggered [A1].				

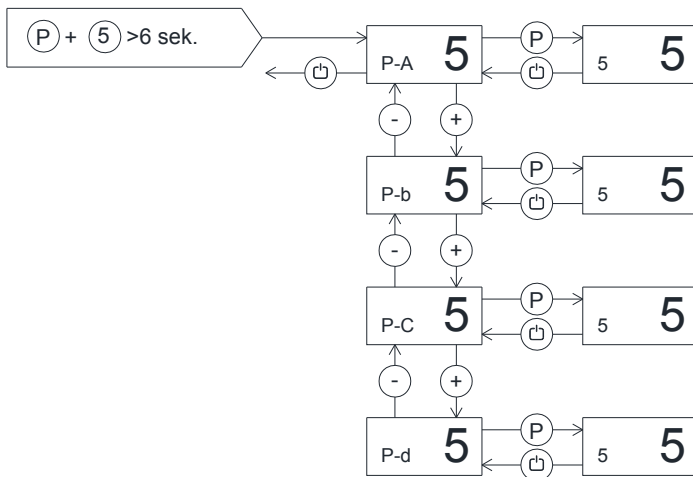

Reset the controller to factory setting

To reset the controller to factory settings:

Push **P** + **1** + **3** for more than 6 seconds. The display shows [**RES**]. Push **P**, and a beep sounds for confirmation”.

Changing door hinge side.

The door can be changed from left hand-hinged to right hand hinged or vice versa.

Example: Changing from right hand to left hand hinged door.

1. Disconnect the cabinet at the mains. Åbn frontpanelet ved at vippe det opad. Afmonter hængsel pos. A.
2. Løft døren ud af det nederste hængsel pos. B. Afmonter nu hængsel pos. B.
3. Fodpedalen pos. C afmonteres, og ny fodpedal Pos. F monteres.
4. Hængslet fra Pos. B monteres nu i pos. E.
5. Døren drejes 180° i forhold til den oprindelige montering.
6. Selvlukkemekanismen flyttes fra pos. A til pos. D.
7. Selvlukke-mekanismen sættes i neutral stilling (se fig. 1). Kontroller med en skiftenøgle, at der er fjedermodstand i begge retninger.
8. Døren sættes ned i hængslet pos. E.
9. Hængslet fra Pos. A monteres nu i pos. D.
10. Dækslet til elkassen afmonteres.
11. Flyt låsen til modsat side, og monter afdækningsprop i modsat side.
12. Flyt magnetkontakten til modsat side.
13. Dækslet til elkassen monteres igen.
14. Frontpanelet lukkes. Strømmen kan nu tilsluttes igen.

Regarding left hand hinged doors to be changed to right hand hinged, the procedure is reversed.

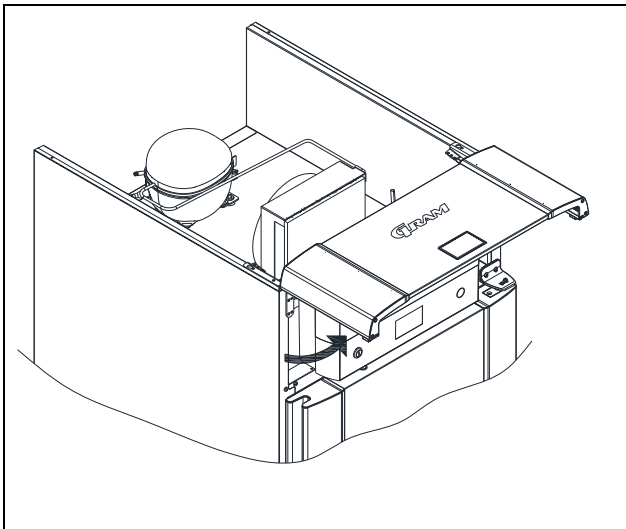

Opening the front panel.

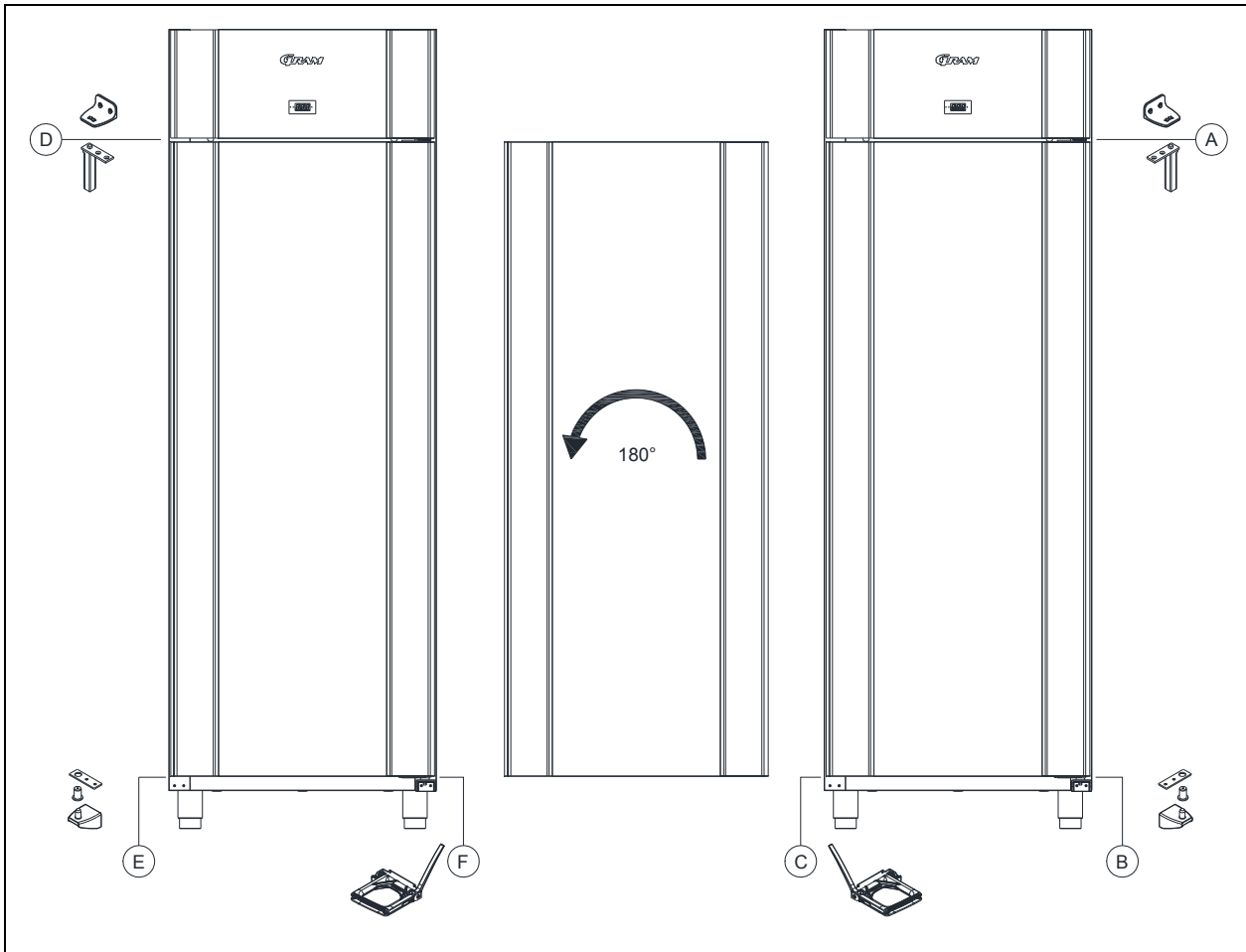

Reversing the door.

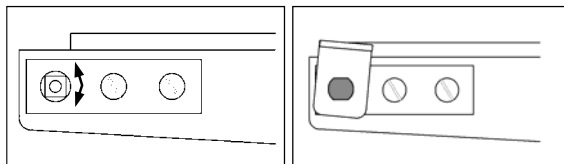

Adjustment of self-close device.

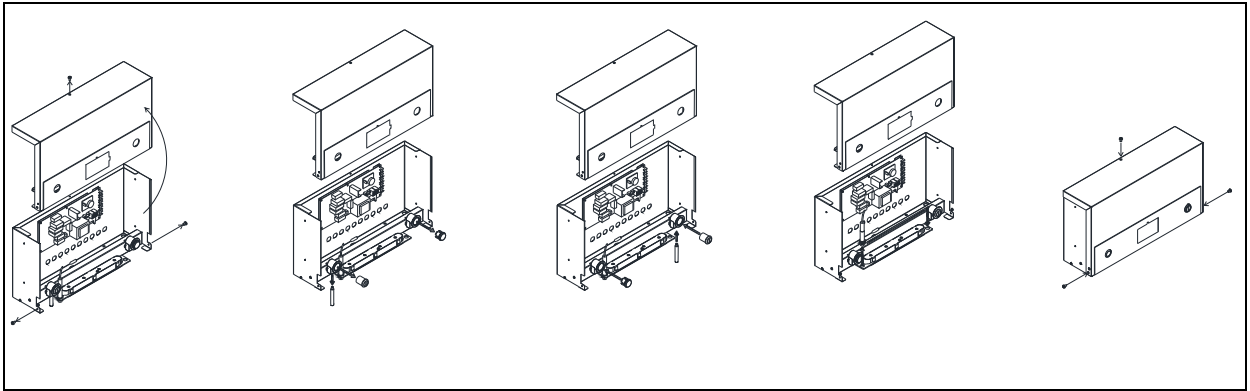

Reversing the lock and door switch.

Plug connections onboard the controller

The description here below explains the plugs or terminals to each special function and relay.

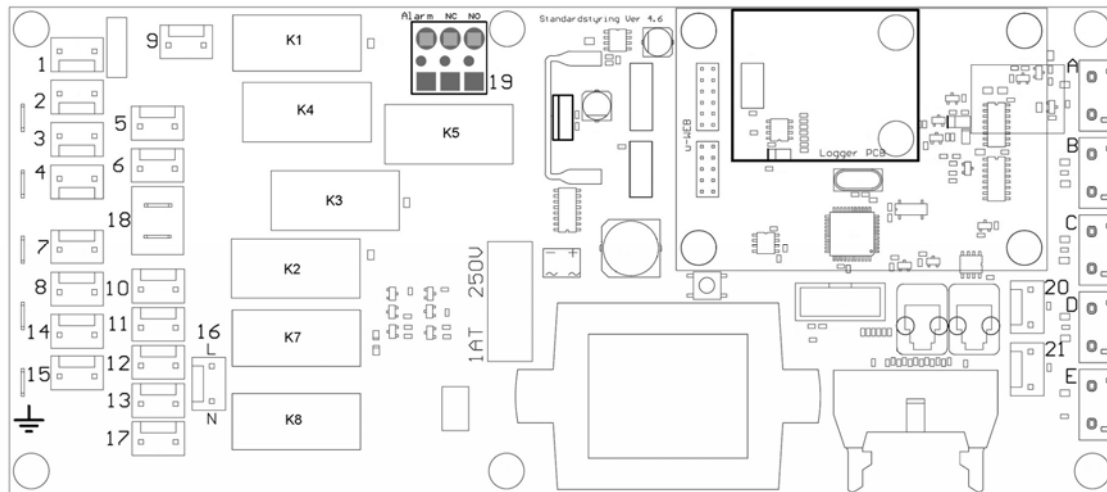

Plug	Electrical component	Description
1	230 Volt relay – K1	The relay supplies the compressor and the condenser fan with power.
2		
3		
4		
5	230 Volt relay – K3	The relay supplies the evaporator fan with power.
6		
7	230 Volt relay – K2	The relay supplies the defrosting heating element and the drip water heating element with power
8		
14		
15		
9	230 Volt relay – K4	The relay supplies the halogen light transformer with power (230V/12V).
10	230 Volt relay – K7 and K8	The relay supplies the front frame heater, re-evaporating heating element, and the condensing pump with power. When the cabinet is switched on, the power is constantly viable.
11		
12		
13		
17		
18	Plug connection for the safety thermostat	The plug is connected in series with the defrosting heating element.
19	230 Volt relay – K5	The potential free alarm relay. The relay changes position when the cabinet switches the power on. By alarms and by power failure the relay switches back to normal position.



16	230 Volt input	These terminals are the power input connection with 230 V to the controller.
20 21	Digital input from the door contact	When these terminals are not in use, the controller lets the evaporator fans keep running. By shortcutting the terminals, the fan stops.
A	Room sensor input	NTC sensor
B	Evaporator sensor input	NTC sensor
C	Condenser sensor input 1	NTC sensor
D	Condenser sensor input 2	NTC sensor
E	Sensor input for a extra sensor	NTC sensor