

RU1 & CO2 REMOTE OPERATION, MAINTENANCE AND INSTALLATION MANUAL



	<u>PAGES</u>
EN: OPERATION, MAINTENANCE AND INSTALLATION MANUAL	1-42
FR: MANUEL D'UTILISATION, D'ENTRETIEN ET D'INSTALLATION	43-84
DE: BEDIENUNG-, WARTUNGS- UND MONTAGEANLEITUNG	85-126
ES: MANUAL DE OPERACIÓN, MANTENIMIENTO E INSTALACIÓN	127-168
NL: EXPLOITATIE- ONDERHOUD- EN INSTALLATIEHANDLEIDING	169-210
DA: BETJENINGS-, VEDLIGEHOLDELSSES- OG INSTALLATIONS	211-252
IT: MANUALE D'USO, DI MANUTENZIONE E DI INSTALLAZIONE	253-294
SV: HANDBOK FÖR ANVÄNDNING, UNDERHÅLL OCH INSTALLATION	295-336
NO: DRIFTS-, VEDLIKEHOLDS- OG INSTALLASJONSHÅNDBOK	337-377

Contact Details:

HOSHIZAKI EUROPE B.V.

Address: Burgemeester Stramanweg 101 1101 AA Amsterdam, The Netherlands

Tel: +31 (0)20 691 84 99 - <http://hoshizaki-europe.com/>





Contents

Application	3
Safety Information	4
Location	5
Electrical Connection.....	7
General Use	8
Operating the Product (Evco Controller – RU1 Model).....	9
Operating the Product (Danfoss Controller AK - CC55)	10
Operating the Product (Carel MPXpro controller)	13
Operating the Product (No Controller – NC model)	19
Troubleshooting.....	19
Defrost Water	20
Door Closing Mechanism	20
Power Failure	20
Cleaning	20
Door Gaskets.....	21
Long Term Storage.....	21
Service	21
Technical Data.....	22
Dimensions.....	24
Disposal.....	31
Electrical Wiring Diagrams	32
Cooling Diagrams	38

HOSHIZAKI

Premier Remote Cabinets



Thank you for choosing a quality product from Hoshizaki.

This manual will advise you on how to install, use, and maintain your new product.

Before our products leave the factory, they undergo a full function and quality test. Should you nevertheless experience problems with the product, then contact your local dealer.

Hoshizaki subsidiaries and dealers placed all over the world are ready to help you.

Products produced by Hoshizaki are covered by different warranty terms related to the country in which the product is sold. This warranty is subject to correct use according to specifications, where e.g. common maintenance and eventual repairs are carried out by technicians appointed by the dealer and with a general knowledge of the product.

Changes in installation and other uses of the product than specified in this manual might affect the operation and durability of the product.

The manual is written according to our current technical knowledge. We constantly work on updating this information, and we reserve the right to make technical changes.

Application

The product is intended for the storage of foodstuffs in non-household environments.

The product is designed for storage at a constant temperature and cannot be used for chilling down or freezing hot/fresh foodstuff.

The product is only to be used for the purpose for which it has been expressly designed. Any other use could cause the foodstuff stored in the product is not kept at the correct temperature or even damage the product.

The product is not suited for storing blood plasma, laboratory samples, pharmaceuticals, or similar substances.

The manufacturer will not be held liable or responsible for any damage caused by improper, incorrect, or unreasonable use of the product.



Safety Information

Important

Description of symbols used in this manual.



Warning Lacking observation to these instructions might result in accidents with personal injury.



Important If these instructions are not observed, the product might be damaged or destroyed.

Be aware that Hoshizaki has taken precautions to ensure that the safety of the product is in order.

Please read carefully the following information regarding safety.



It is important, that everyone who is to use or install the product, has access to this manual.



This appliance is not intended for use by persons with reduced physical, sensory, or mental capabilities, or lack of experience and knowledge unless they have been given supervision or instruction concerning the use of the appliance by a person responsible for their safety.



Children should be supervised to ensure that they do not play with the appliance.



The appliance might contain parts with sharp edges in the compressor compartment and in the inside compartment.



The appliance is not to be transported on a sack truck, there is a danger of losing the balance, causing danger to persons.



Do not pull the power cord to disconnect the appliance, or when moving the appliance.

Location

When receiving the product, check the packaging material for damage.

If any damage occurs to the packaging material, it should be considered if the product might have been damaged too. If the damage is substantial, please contact your dealer.



This task requires at least 2 persons. The heaviest part of the product is at the top. Be aware of this, when removing the transport pallet.



Because of the heavy weight of the product, the floor might be damaged or scratched when moving the product.



Correct set up gives the most effective operation.



The product should be located in a dry and adequately ventilated room.



To ensure efficient operation, it may not be placed in direct sunlight or against heat-emitting surfaces. The product is designed to operate in an ambient temperature between +16°C and +40°C.



Avoid placement of the product in a chlorine/acid-containing environment (swimming bath etc.) due to risk of corrosion.



The product and parts of the interior is equipped with a protecting film, which should be removed before use.



Clean the product with a mild soap solution before use.

The set up place must be level and horizontal.

For versions with legs, use the adjustable legs to make sure that the product stands level and upright.

For versions with castors, the locking devices of the two front castors must be activated, when the product is in place.

HOSHIZAKI

Premier Remote Cabinets



There must always be 500 mm of free space above the product, to allow for service. The product should be placed as close as possible up against the wall.

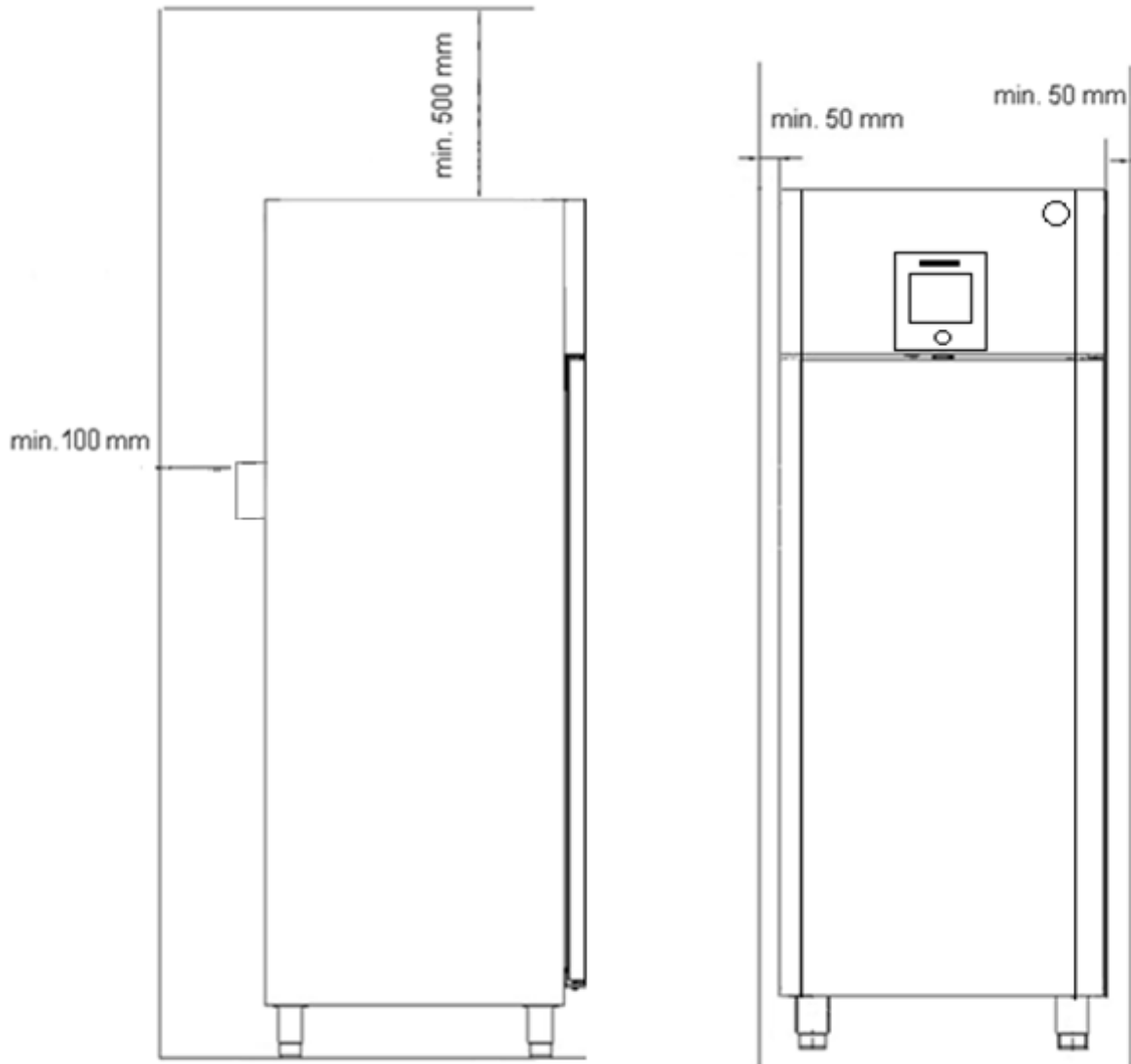

Electrical Connection

Read the text below thoroughly before electrical connection.



The product is intended for connection to alternating current. The connection voltage (V) and frequency (Hz) are shown on the nameplate in the cabinet



Never use an extension cord for this appliance!

If a wall socket is placed at a longer distance than the length of the supplied power cord, contact an electrician to establish a wall socket within the range of the power cord.



If the product is faulty, **it should be examined by a qualified service technician** who is familiar with the installed control unit and has experience maintaining the CO2 cabinet.



In general, it must be examined by the company that has connected the product.



Always disconnect the power if interruptions in the power supply occur, when electrical parts are removed/put on, and before cleaning and maintenance of the product.



Do not use the product without all protective parts installed to avoid touching live or rotating machine parts

The product is not to be used outdoors.



All earthing requirements prescribed by local electrical authorities must be complied with. The plug and wall socket must then ensure proper grounding. Consult an electrician if necessary.



Make sure the product is switched off at the socket or that the kettle plug is disconnected, before service is performed on electrical parts. It is not sufficient to switch off the product at the controller.

General Use



Do not damage the refrigeration system parts.



If the product is fitted with a re-evaporation tray underneath the cabinet it is important not to service/clean the tray or the heater, before the cabinet has been turned off long enough to make sure that the re-evaporation heater has cooled off, in order to prevent the risk of burns.



Do not use electrical devices inside the product.



To ensure correct and efficient air flow in the cabinet, the shaded areas must be kept free of items.



All items to be stored, that are not wrapped or packed, must be covered in order to avoid unnecessary corrosion of the inner parts of the cabinet.



If any controller parameters are changed from default, this could cause that the product is not functioning normally, and harmful temperatures could damage items that are kept inside the product.



Maximum loading of shelf: 40 kg



Do not store explosive substances such as aerosol cans with flammable propellant in this appliance.



Do not place any products below the bottom shelf support or above the top load line marking.

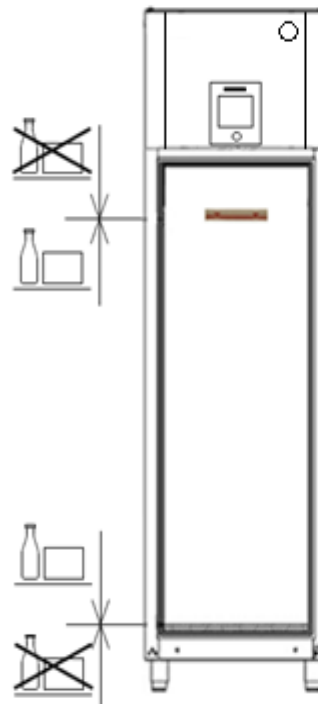

Do not store goods above the top loading mark

Do not store goods below the bottom grate

Operating the Product (Evco Controller – RU1 Model)

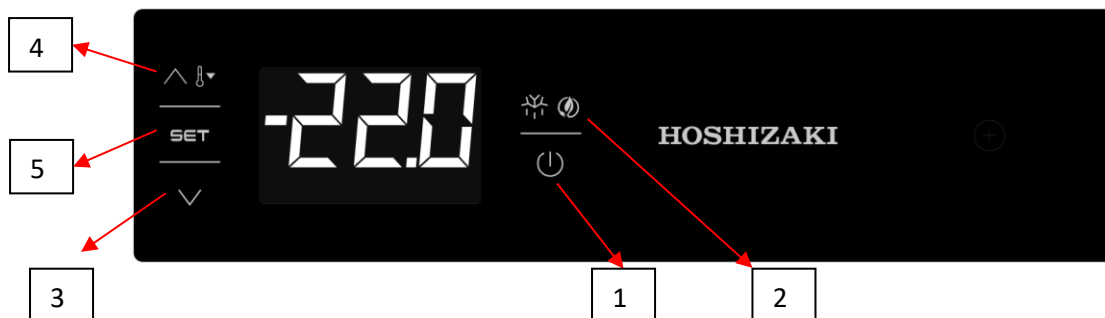

➤ FRONT PANEL FUNCTIONS

To lock the front panel keys, hold AUX (3) and hold On / Stand By (1) for 2 seconds: "Loc" text will be on the screen when keys are locked, if it isn't locked, "UnL" text will be on the screen.

1) When holding **ON/STAND BY** for 4 seconds; the device opens or closes. (On/Off)

2) **MANUAL DEFROST**; if the button is pressed for 4 seconds, manual defrost starts. If excessive cooling is active and evaporator temperature is not suitable, manual defrost will not start.

3) **DOWN** key: Scroll down the menu or reduce the value; if held down for 4 seconds super cooling becomes active. When an excessive cooling function is active, the set temperature can be reduced; the time and temperature are determined with the help of the parameters. When an excessive cooling function is activated, the device never does defrost.

4) **UP** Key: Scroll up the menu or increase the value; if held down for 4 seconds, the percentage of low and high relative humidity function is engaged. (For some models) "rhL" is written on the screen (A low percentage of relative humidity function is operating.) or "rhH" is written on the screen (A high percentage of relative humidity function is operating.) These functions appear on the screen for 10 seconds. If humidity control is not available, "----" appears on the screen for 1 second.

5) **SET** key: input and change key for adjustable values.

➤ OPERATING

Operation cases are available below:

"On" status: The device is energized and the device operates.

"Stand-By" status: The device is switched off, but the device is still powered.

"Of" status: To turn the device off, remove the plug from the socket, or by turning the main fuse off, the device is turned off.

Operating the Product (Danfoss Controller AK - CC55)

Starting up:

Plug in the appliance.

Make sure that the 2 - pole main switch is turned on.

Display explanation (AK-UI55):

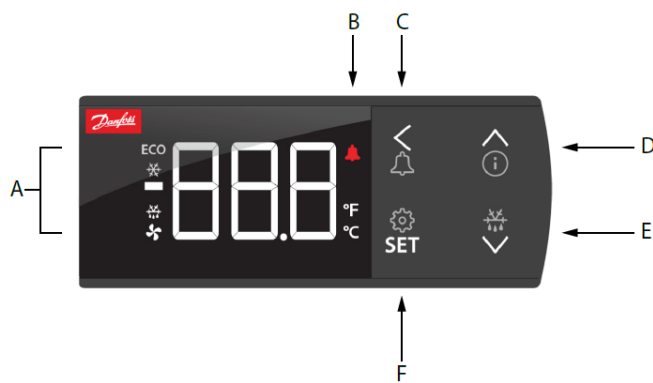

Display Parts	Description
A	Lights up in event of:  <ul style="list-style-type: none"> - Energy Optimization (ECO) - Cooling - Defrosting - Fan Operation
B	Lights in event of alarm
C	Long press (3 seconds) on alarm button alarm (relay is reset) alarm code displayed
D	Long press (3 seconds) gives access to the information menu “InF” (Please look figure “b”) Up arrow / Down arrow / Arrow to left: Navigation in the menu and setting of values.
E	Long press (3 seconds) will start a defrost, “-d-” is shown in the display. Ongoing defrosting can be stopped by a long press.
F	SET: Long press (3 seconds) gives access to the “SET” menu. If the operation is locked with a password “PS” is shown. Enter the code. * Shows the setting for a chosen parameter / saves a changed setting. Short press gives access to entering of the thermostat’s cut-out limit.

* The factory setting of P89 is '0', this step will be skipped without any input values.



a- "SET" Button Parameter List

SET	←	SET button, 3 s: Configuration settings	
Set			
(PS) v	←	PS: Password (if any)	
cFg	SET →		r12 Main switch
v			o61 Application
r--	Menu groups See also the following pages.		o03 MODBUS address
A--		r89 Food type	
c--		r00 Cut-out temperature	
d--		r15 Ther. sensor S4 %	
n--		r61 Ther. sensor S4% night	
F--		A36 Alarm sensor S4%	
t--		o17 Display air S4%	
h--		o30 Refrigerant type	
o--		o20 Min. transmitter range	
p--		o21 Max. transmitter range	
q--		d01 Defrost method	
u--		d03 Defrost interval	
<		d10 Defrost sensor	
(Return)		d04 Max. defrost time	
	d02 Defrost stop temperature		
	<		
	(Return)		

b - "Info" Button Parameter List

^	←	Info button, 3 s: Information for service use	
Inf			
StA	SET	See control state message	
App	SET	See selected application	
in	SET →		Al1 (PE)
out	SET →		Al2 **
buS	SET	MODBUS quality	Al3 **
SoF	SET	See SW version	Al4 **
<			Al5 **
(Return)			di1 **
			di2 **
			<
			(Return)

do1	*	Read output status
do2	*	
do3	*	
do4	*	
Ao1	**	Read input status
<		
(Return)		

Output status
When you want info on a relay output, the dot will show whether the relay is activated (energized)
for e.g.:
do4 = not activated
do.4 = activated

Fault Message (Alarms)



In an error situation the alarm LED on the front will be on and the alarm relay will be activated (depending on priority). If you push the alarm button for 3 seconds you can see the alarm report in the display.

For more information, please see the manual for the selected CO2 controller.
(Danfoss AK-CC55 Compact)

Code	Alarm text	Description
E01	Hardware failure	The controller has a hardware failure
E06	Clock lost time	Clock has lost valid time
E20	Pe Evap. pressure A - Sensor error	Sensor signal is out of range. Please check the sensor for correct operation
E24	S2 Gas outlet A - Sensor error	Sensor signal is out of range. Please check the sensor for correct operation
E25	S3 Air ON evap. A - Sensor error	Sensor signal is out of range. Please check the sensor for correct operation
E26	S4 Air OFF evap. A - Sensor error	Sensor signal is out of range. Please check the sensor for correct operation
E27	S5 Evaporator A - Sensor error	Sensor signal is out of range. Please check the sensor for correct operation
A01	High temperature alarm A	The alarm temperature has been above the max alarm limit for a longer time period than the set alarm delay.
A02	Low temperature alarm A	The alarm temperature has been below the min alarm limit for a longer time period than the set alarm delay.
A04	Door open alarm	The door has been open for a too long time
A05	Max defrost hold time exceeded	The controller has been waiting longer time than permitted after a co-ordinated defrost.
A11	Refrigerant not selected	The refrigerant has not been selected hence control can not be initiated
A15	DI alarm 1	Alarm signal from digital input signal
A16	DI alarm 2	Alarm signal from digital input signal
A45	Main switch set OFF	The controller main switch has been set to either Stop or Manual control. Alternatively a digital input set up for "main switch" function, has stopped control
A59	Case in cleaning mode	A case cleaning operation has been started on a case
AA2	CO ₂ leak detected	CO ₂ is leaking from the refrigeration system
AA3	Refrigerant leak detected	Refrigerant is leaking from the refrigeration system
a04	Wrong IO configuration	Inputs and outputs have not been configured correctly

Operating the Product (Carel MPXpro controller)

Starting up

Plug in the appliance

Default setting of the cabinet controller is that it is delivered turned on. This means that the controller will start regulating, when power supply is connected, and the main switch is in the on position.

Turning the cabinet on/off

To turn the cabinet on/off the 2-pole main switch, on the left side of the main control box, placed in “the compressor compartment” is used.

The display



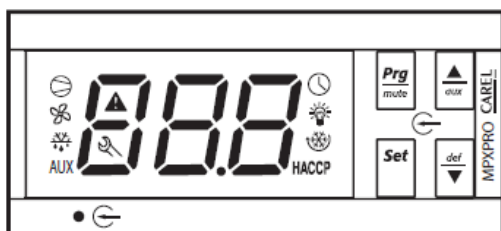

Display layout/explanation:



The above shown display has a three-digit read-out.

Within the read-out area, several LEDs are placed. These LEDs give the following indications.

In general = When a LED is flashing the activation is delayed or limited.

-  = Cooling on (when this LED is lit, cooling is on)
-  = Inside fan running (when this LED is lit, the internal/evaporator fan is on)
-  = Defrost on (when this LED is lit, a defrost cycle is ongoing)
-  = If the LED is flashing, this is an indication for the door being open or an ongoing alarm or error.

HACCP = When this LED is lit, a HACCP alarm is ongoing. When this LED is flashing there is a saved HACCP alarm.





Buttons:

The 4 buttons placed on the right side of the display, are used to access and adjust different parameters. These buttons can be pressed alone or in combination in order to operate the controller.



The below explained settings are the only once which should be changed by the end user. The end user should not modify any parameters which are not explained here. All other settings should be done by a skilled technician.

USER SETTINGS

Adjusting the cabinet temperature set-point

- Press and hold Set  during normal operation until the display starts flashing, the cabinet temperature set-point can be adjusted using up  and down . 
- When the set point has been adjusted to the desired temperature, Set  is pressed briefly, in order to save the new value and to return to normal operation.

























How to perform a manual defrost

- Press and hold def  for more than 5 sec. during normal operation, in order to perform a manual defrost, if the evaporator probe temperature is cold enough.
- When the defrost symbol  is lit, it does indicate that a defrost is ongoing.
- if def  is pressed and held for more than 5 seconds when a defrost cycle is ongoing, the defrost will be deactivated.

How to mute acoustic alarms

- When the controller is in alarm mode, you will hear an acoustic signal. The alarm can be muted by pushing Prg/mute .









Setting the temperature alarm limits

- Press and hold Prg/mute  for more than 5 sec. during normal operation, in order to open the parameter list. The display will show **lc1**
- Press Prg/mute . The first category of parameters, “Pro”, is shown
- Press UP  until reaching category “ALn”, indicated by the  icon being lit on the display.
- Press Set  parameter AA will be displayed.
- Press UP  until reaching A1
- Press Set  in order to adjust if AL (**A**larm **L**ow temperature threshold) and AH (**A**larm **H**igh temperature threshold) settings shall be (0 = relative to the cabinet temperature setpoints) or (1 = absolute) default setting = 1
- Press Set  in order to store the chosen setting and return to A1
- Press UP  until reaching AL (**A**larm **L**ow temperature threshold)
- Press Set  to make it possible to adjust AL using up  and down  (adjustable between -50 and +50) Default setting = -50°C
- press Set  in order to store the chosen setting and return to AL
- press UP  until reaching AH (**A**larm **H**igh temperature threshold)
- press Set  to make it possible to adjust AH using up  and down  (adjustable between -50 and +50) Default setting = +50°C
- press Set  in order to store the chosen setting and return to AH
- press UP  until reaching Ad (**A**larm **D**elay time for AL and AH)
- press Set  to make it possible to adjust Ad using up  and down  (adjustable between 0 and 240 minutes) Default setting = 120 minutes.
- press Set  in order to store the chosen setting and return to Ad
- Push and hold Prg/mute  for more than 5 sec. in order to save changes, and the revert to the main menu.

In order to create temperature alarm thresholds and alarm delay time suitable for a refrigerator or a freezer the below alarm setting examples can be suggested:

	Setpoint	A1	AL	AH	Ad
Refrigerator	+5 °C	1	+1 °C	+8 °C	120 min.
Freezer	-18 °C	1	-50 °C	-15 °C	120 min.

How to display the alarm log

- Press Prg/mute  and Set  and hold for 5 seconds;
- enter the password: 44
- Press Set  to access a submenu where UP  and DOWN  are used to scroll the various alarms, HS0 to HS9;
- Select an alarm and press Set  to display the code, hour, minutes and duration;
- From any of the sub parameters, pressing Prg/mute  will make the controller return to the parent parameter “HSx”;
- Press Prg/mute  for 5 seconds to return to the standard display.

Example :

‘HI’ -> ‘h17’ -> ‘m23’ -> ‘65’

indicates that alarm ‘HI’ (high temperature alarm) was activated at 17:23 and lasted 65 minutes.









HACCP ALARMS

Two types of HACCP events are managed:

- type HA alarms, high temperature during the operation;
- type HF alarms, high temperature after power failure (blackout).

When an alarm is recorded, the HACCP LED flashes, the display shows the alarm code, the alarm is saved, and the alarm relay and buzzer are activated.



How to display the HA and HF alarms

- Press Prg/mute  and DOWN  simultaneously
- Scroll the list of alarms pressing UP  and DOWN 
- Press Set  to select the required alarm
- Use UP  or DOWN  to see the description of the alarm: year, month, day, hours, minutes and duration in minutes of the selected alarm
- Press Prg/mute  again to return to the previous list.

In addition, the HACCP alarm menu allows the following operations:



How to delete a HACCP alarm

- Press Set  & DOWN  for 5 seconds when displaying the list of alarms.

This causes the HACCP to flash, the display shows the message rES and the monitoring of HACCP alarms is reinitialised

How to delete the entire memory of HACCP alarms

- Press Set  & UP  & DOWN  for 5 seconds.

This procedure displays the message rES, deletes the entire memory of alarms and reinitialises the monitoring of the HACCP alarms.

In order to be able to use the HACCP alarms, it is necessary that the real time clock has been adjusted by the installing company prior to handing over the cabinet to the end user. These adjustments are protected by an access code and can therefore not be made by the end user.

Cabinet Light

On all cabinets the cabinet light is placed on the cabinet outside, above the door. This light is operated by the main controller which means that the way it works cannot be changed.

When the cabinet door is opened the light above the door is turned on. When closing the door, the cabinet light above the door will turn off.

HOSHIZAKI

Premier Remote Cabinets



Errors and Alarms

Display code	Cause of the alarm	Icon flash on display	Alarm relay	Buzzer	Reset	Compressor	Defrost	Evaporator fans	Continuous cycle	Signalled on tLAN	Network solenoid valve
rE	Control probe fault		ON	ON	automatic	duty setting(c4)	unchanged	unchanged	unchanged	√	-
E1	Probe S1 fault		OFF	OFF	automatic	duty setting(c4)	unchanged	unchanged	unchanged	√	-
E2	Probe S2 fault		OFF	OFF	automatic	unchanged	unchanged	unchanged	unchanged	√	-
E3	Probe S3 fault		OFF	OFF	automatic	unchanged	unchanged	unchanged	unchanged	√	-
E4	Probe S4 fault		OFF	OFF	automatic	unchanged	unchanged	unchanged	unchanged	√	-
E5	Probe S5 fault		OFF	OFF	automatic	unchanged	unchanged	unchanged	unchanged	√	-
E6	Probe S6 fault		OFF	OFF	automatic	unchanged	unchanged	unchanged	unchanged	√	-
E7	Probe S7 fault		OFF	OFF	automatic	unchanged	unchanged	unchanged	unchanged	√	-
E8	Serial probe S8 not updated		OFF	OFF	automatic	duty setting(c4)	unchanged	unchanged	unchanged	√	-
E9	Serial probe S9 not updated		OFF	OFF	automatic	duty setting(c4)	unchanged	unchanged	unchanged	√	-
E10	Serial probe S10 not updated		OFF	OFF	automatic	duty setting(c4)	unchanged	unchanged	unchanged	√	-
E11	Serial probe S11 not updated		OFF	OFF	automatic	duty setting(c4)	unchanged	unchanged	unchanged	√	-
LO	Low temperature alarm		ON	ON	automatic	unchanged	unchanged	unchanged	unchanged	√	-
HI	High temperature alarm		ON	ON	automatic	unchanged	unchanged	unchanged	unchanged	√	-
LO2	Low temperature alarm		ON	ON	automatic	unchanged	unchanged	unchanged	unchanged	√	-
HI2	High temperature alarm		ON	ON	automatic	unchanged	unchanged	unchanged	unchanged	√	-
IA	Immediate alarm from external contact		ON	ON	automatic	duty setting(A6)	unchanged	unchanged	unchanged	√	-
dA	Delayed alarm from external contact		ON	ON	automatic	duty setting(A6) if A7≠0	unchanged	unchanged	unchanged	√	-
dor	Door open for too long alarm		ON	ON	automatic	unchanged	unchanged	unchanged	unchanged	√	-
Etc	Real time clock fault		OFF	OFF	automatic	unchanged	unchanged	unchanged	unchanged	√	-
LSH	Low superheat alarm		OFF	OFF	automatic	OFF	unchanged	unchanged	unchanged	√	√
LSA	Low suction temperature alarm		OFF	OFF	automatic / manual	OFF (paragraph 6.10)	unchanged	unchanged	unchanged	√	√
MOP	Maximum evaporation pressure alarm		OFF	OFF	automatic	OFF	unchanged	unchanged	unchanged	√	√
LOP	Low evaporation temperature alarm		OFF	OFF	automatic	unchanged	unchanged	unchanged	unchanged	√	√
bLo	Valve blocked alarm		OFF	OFF	manual/ disabled with P14=0	unchanged	unchanged	unchanged	unchanged	√	-
Edc	Communication error with stepper driver		ON	ON	automatic	unchanged	unchanged	unchanged	unchanged	√	-
EFS	Stepper motor broken/not connected		ON	ON	automatic	unchanged	unchanged	unchanged	unchanged	√	-
EE	Flash unit parameter error		OFF	OFF	automatic	OFF	not performed	OFF	not performed	√	-
EF	EEPROM operating parameter error		OFF	OFF	automatic	OFF	not performed	OFF	not performed	√	-
HA	Type HA HACCP alarm	HACCP	OFF	OFF	manual	unchanged	unchanged	unchanged	unchanged	√	-
HF	Type HF HACCP alarm	HACCP	OFF	OFF	manual	unchanged	unchanged	unchanged	unchanged	√	-
MA	Communication error with Master (only on Slave)		ON	ON	automatic	unchanged	unchanged	unchanged	unchanged	-	-
u1...u5	Communication error with Slave (only on Master)		ON	ON	automatic	unchanged	unchanged	unchanged	unchanged	-	-
n1...n5	Alarm on unit 1 to 5 in the network		ON	ON	automatic	unchanged	unchanged	unchanged	unchanged	-	-
up1...up5	Upload procedure with errors on unit 1 to 5		OFF	OFF	-	unchanged	unchanged	unchanged	unchanged	-	-
GPE	Error in custom gas parameters		ON	ON	automatic	OFF	not performed	OFF	not performed	√	-



For more information, please see the manual for the selected CO2 controller.
(Carel MPX PRO)



Operating the Product (No Controller – NC model)



Please see the manual supplied with the installed controller.

Troubleshooting

Noise:

- If abnormal noise occurs, request service assistance.
- Operating sounds from the interior fan are normal.
- If sheet metal parts, front panels or panels in front of the compartment are making noise, these might be open. Close the panels.

Frosting inside compartment:

- Ambient humidity too high.
- The door is opened too often.
- The door is left open for too long.
- Damaged door gasket. Check it thoroughly for damages.

Poor cooling performance:

- Ambient temperature too high.
- The door is opened too often and/or open for too long.
- The door is left open.
- Damaged door gasket.
- Temperature setting too high.
- Product too packed with foods - air inlet/outlet blocked.
- Warm or hot foods inside the product.
- Defrost in progress. The cabinet temperature may rise temporarily during the defrost cycle, but it will not affect the foods inside. The defrost LED is lit.

Some of the foods are frozen:

- Product too packed with foods - air inlet/outlet blocked.
- Temperature setpoint too low.
- Evaporator fan might be defective.

Condensation around the door:

- Ambient humidity too high.
- The door is not closed tightly.
- Damaged door gasket.
- Parameter related to door frame heater has not been adjusted correctly.

Too high energy consumption:

- Ambient temperature too high.
- The door is opened too often and/or open for too long.
- The door is left open.
- Damaged door gasket.
- Temperature setpoint too low.
- Product is too packed with foods - air inlet/outlet blocked.
- Warm or hot foods are brought into the product.
- Product is placed in direct sunlight or close to heat-emitting surfaces.
- The default settings have been changed.



Defrost Water

During defrosting, the product produces water, which is led into the re-evaporation system through a vacuum plastic at the top of the cabinet (For Premier Cabinets)

The water is re-evaporated with an electrical heating element and fan motor. In rare cases the use pattern of the cabinet creates more water than the product is capable of re-evaporating, which means that overflow of water can occur. If this happens the electrical heating element can be changed to run 100% or alternatively be disconnected and instead connect the water pipe on the back to a drain. These changes must be carried out by a skilled service technician.

Door Closing Mechanism

The door is equipped with a self-closing system. If the door is opened less than 90°, it will close by itself. If the door is opened more than 90°, it will stay open.

The door can be opened by using the foot pedal. This leaves both hands free when placing foodstuffs in the cabinet.

Power Failure

In the event of a power failure, the control remembers the temperature setting and restarts the product when power is restored.

Cleaning

Insufficient cleaning will cause that the product will not work at optimum performance, or eventually it will be defective.



Before cleaning, the product should always be disconnected.



Do not flush the product with water, do not use water jet or steam hose as this may cause short-circuits in the electrical system.



Cleansing agents containing chlorine or compounds of chlorine as well as other corrosive means, **are not to be used**, as they might cause corrosion to the stainless panels of the cabinet and the evaporator.



The product must be kept free from dust and dirt. This is best done with a vacuum cleaner and a brush.



For the external maintenance – use stainless steel polish.



The product should be cleaned internally with a mild soap solution at suitable intervals and checked thoroughly before it is put into operation again.



Door Gaskets

This chapter deals with the importance of a well-functioning door gasket.

Gaskets are an important part of a refrigerator/freezer. Gaskets with reduced functionality, reduces the tightness of the cabinet. Reduced tightness might cause increased humidity, internal icing, an iced up evaporator (leading to reduced refrigeration capacity), and in worst case reduced lifecycle of the cabinet.



Therefore, it is important to be aware of the condition of the gasket. Regular inspection is recommended.

The gasket should be cleaned regularly with a mild soap solution. If a gasket needs replacement, contact your supplier.

Long Term Storage

If the product is taken out of operation, and need to be prepared for long-term storage, clean the inside compartment, the door and door gasket thoroughly with a hot soapy damp cloth. Eventual remnants of food could create mold.

Service

If refrigeration fails, first investigate whether the unit has been unintentionally disconnected or switched off at the socket, or whether a fuse has blown.

If it is not possible to find the cause of the refrigeration failure, please contact the installer of the unit.

When contacting HOSHIZAKI or the Installer please inform us the name and serial number inside of the cabinet. This information is stated on the name plate,









HOSHIZAKI

Premier Remote Cabinets



Technical Data

Placement of the label:

PRODUCT DESCRIPTION LABEL																														
1 Product Number		<table border="1" style="width: 100%; border-collapse: collapse;"> <tr> <td style="width: 70%;">PRODUCT NUMBER</td> <td style="width: 30%; text-align: center;">1</td> </tr> <tr> <td colspan="2" style="text-align: center;">  </td> </tr> <tr> <td>PRODUCT DESCRIPTION</td> <td style="text-align: center;">2</td> </tr> <tr> <td>MODEL</td> <td style="text-align: center;">3</td> </tr> <tr> <td>REFRIGERANT</td> <td style="text-align: center;">4</td> </tr> <tr> <td>CO2 EQUIVALENT</td> <td style="text-align: center;">5</td> </tr> <tr> <td>IP PROTECTION</td> <td style="text-align: center;">6</td> </tr> <tr> <td>CLIMATE CLASS</td> <td style="text-align: center;">7</td> </tr> <tr> <td>PRODUCTION DATE</td> <td style="text-align: center;">8</td> </tr> <tr> <td>TOTAL POWER / CURRENT / LAMP POWER</td> <td style="text-align: center;">9</td> </tr> <tr> <td>VOLTAGE - FREQUENCY</td> <td style="text-align: center;">10</td> </tr> <tr> <td>HEATING ELEMENT</td> <td style="text-align: center;">11</td> </tr> <tr> <td>SYSTEM PRESSURE</td> <td style="text-align: center;">12</td> </tr> <tr> <td>BLOWING AGENT</td> <td style="text-align: center;">13</td> </tr> </table>	PRODUCT NUMBER	1			PRODUCT DESCRIPTION	2	MODEL	3	REFRIGERANT	4	CO2 EQUIVALENT	5	IP PROTECTION	6	CLIMATE CLASS	7	PRODUCTION DATE	8	TOTAL POWER / CURRENT / LAMP POWER	9	VOLTAGE - FREQUENCY	10	HEATING ELEMENT	11	SYSTEM PRESSURE	12	BLOWING AGENT	13
PRODUCT NUMBER		1																												
																														
PRODUCT DESCRIPTION		2																												
MODEL		3																												
REFRIGERANT		4																												
CO2 EQUIVALENT		5																												
IP PROTECTION		6																												
CLIMATE CLASS		7																												
PRODUCTION DATE		8																												
TOTAL POWER / CURRENT / LAMP POWER		9																												
VOLTAGE - FREQUENCY		10																												
HEATING ELEMENT		11																												
SYSTEM PRESSURE		12																												
BLOWING AGENT	13																													
2 Product Description																														
3 Model																														
4 Refrigerant (GWP)																														
5 CO2 Equivalent																														
6 IP Protection																														
7 Climate Class																														
8 Production Date																														
9 Total power / Current / Lamp power																														
10 Voltage - Frequency																														
11 Heating Element																														
12 System Pressure																														
13 Blowing Agent																														
14 Serial Number	<p>S/N: 14</p>  <p style="font-size: small;">HOSHIZAKI EUROPE B.V. Burgemeester Stramanweg 101 1101 AA Amsterdam, The Netherlands</p> <div style="display: flex; justify-content: space-around; align-items: center;">    </div>																													

Trade mark			HOSHIZAKI			
Model name			PREMIER U 70	PREMIER U 140	PREMIER U 80	PREMIER U 60
Intended use			Storage	Storage	Storage	Storage
Chilled operating temperature			X	X	X	X
Frozen operating temperature			X	X	X	X
Multiuse cabinet						
Vertical cabinet			X	X	X	X
Counter cabinet						
Parameter	Symbol	Unit				
Gross Volume	VnT	L	700	1400	700	480
Climate Class			CC5	CC5	CC5	CC5
Supply Voltage / Frequency	V / Hz		230 - 50	230 - 50	230 - 50	230 - 50
Refrigerant (CO2 Cabinet)			CO2	CO2	CO2	CO2
Refrigerant (RU-1 Cabinet)			HFC / HFO Refrigerant*	HFC / HFO Refrigerant*	HFC / HFO Refrigerant*	HFC / HFO Refrigerant*
Contact details:	<p>HOSHIZAKI EUROPE B.V.</p> <p>Address: Burgemeester Stramanweg 101 1101 AA Amsterdam, The Netherlands</p> <p>Tel: +31 (0)20 691 84 99 - http://hoshizaki.europe.com/</p>					

* Refrigerants that compatible with orifice (R449A, R448A, R45A, etc. Please check the datasheet of using orifice)

HOSHIZAKI

Premier Remote Cabinets



Trade mark			HOSHIZAKI		
Model name			BAKER U 950	BAKER GA 950	PREMIER SF 950
Intended use			Storage	Cooling /Freezing / Storage / Proving	Cooling / Shock Freezing
Chilled operating temperature			X	X	X
Frozen operating temperature			X	X	X
Multiuse cabinet				X	X
Vertical cabinet			X	X	X
Counter cabinet					
Parameter	Symbol	Unit			
Gross volume	VnT	L	1000	950	950
Climate Class			CC5	CC5	CC5
Supply Voltage / Frequency	V / Hz		230 - 50	230 – 50	230 – 50
Refrigerant (RU-1 Cabinet)			HFC / HFO Refrigerant*	HFC / HFO Refrigerant*	HFC / HFO Refrigerant*
Contact details:	HOSHIZAKI EUROPE B.V. Address: Burgemeester Stramanweg 101 1101 AA Amsterdam, The Netherlands Tel: +31 (0)20 691 84 99 - http://hoshizaki.europe.com/				

* Refrigerants that compatible with orifice (R449A, R448A, R45A, etc. Please check the datasheet of using orifice)

HOSHIZAKI

Premier Remote Cabinets



Dimensions

PREMIER U 70

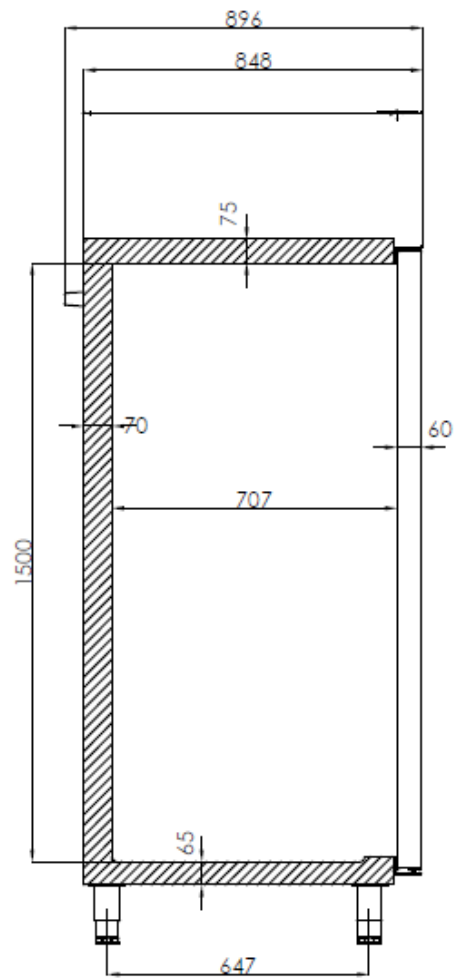
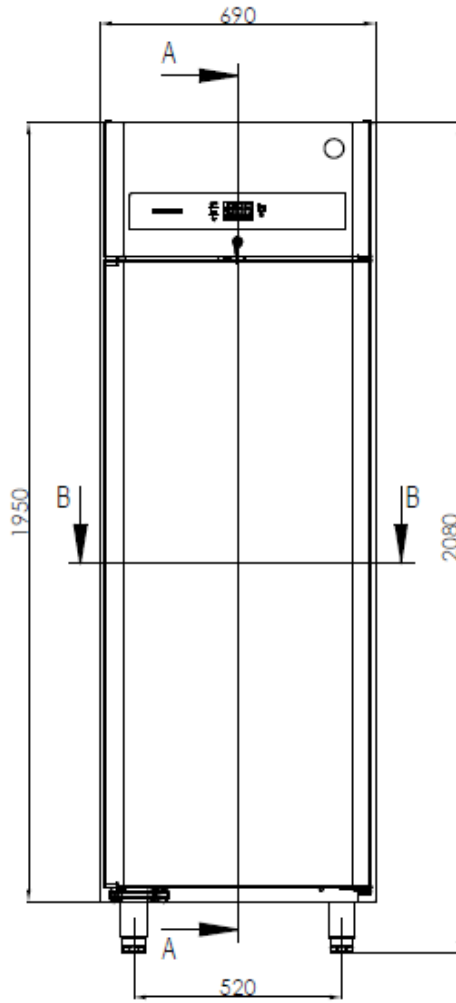

A-A

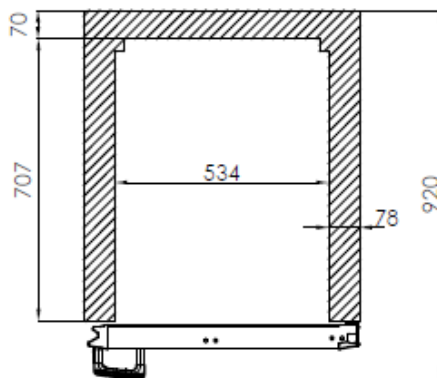

B-B

HOSHIZAKI

Premier Remote Cabinets



PREMIER U 60

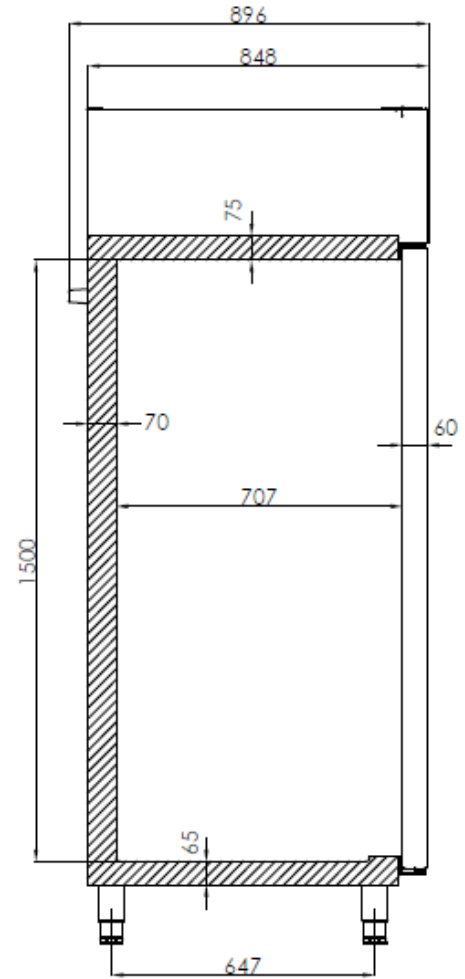
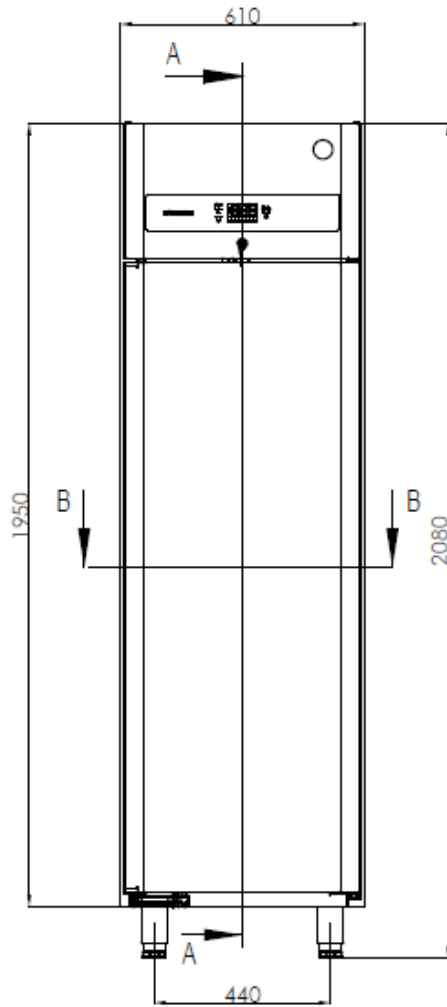

A-A

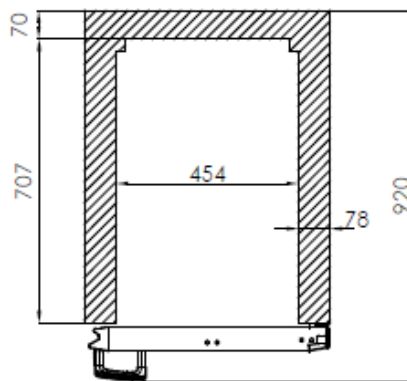

B-B

HOSHIZAKI

Premier Remote Cabinets



PREMIER U 80

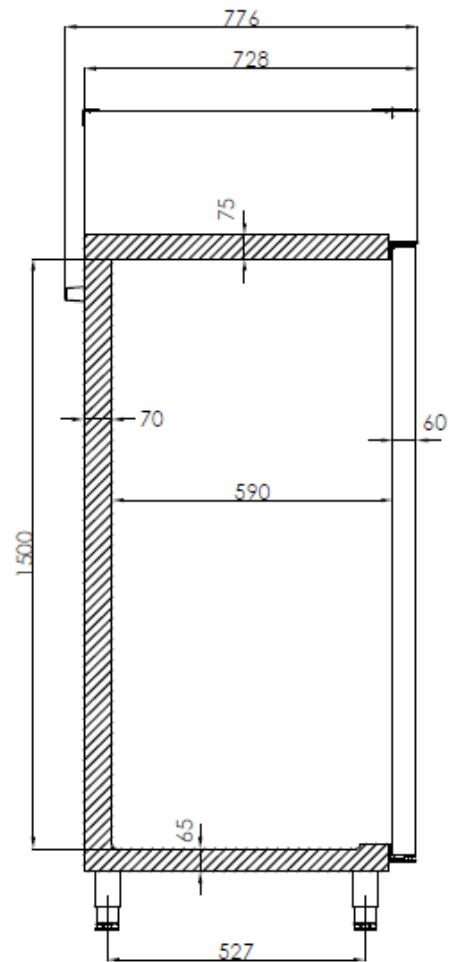
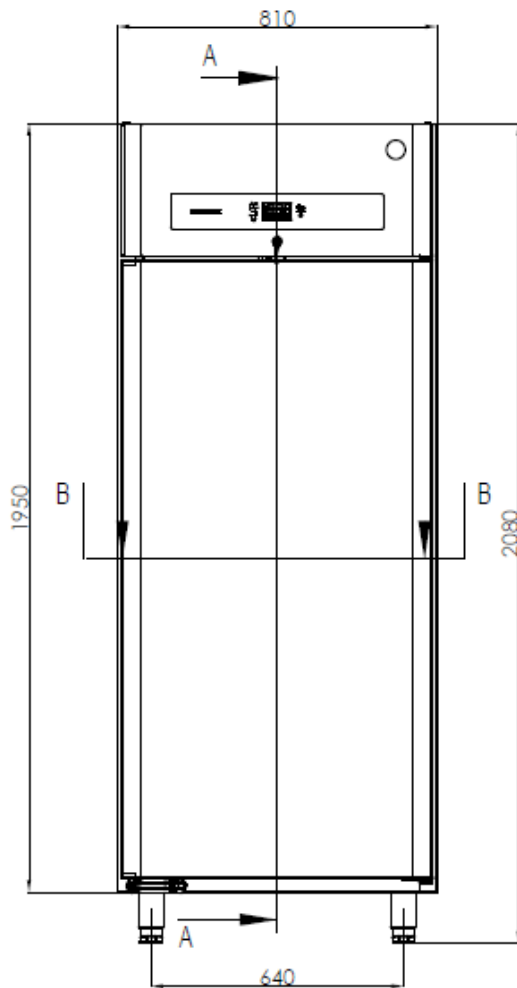

A-A

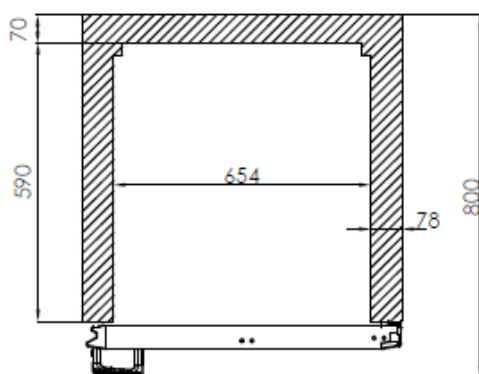

B-B

HOSHIZAKI

Premier Remote Cabinets



PREMIER U 140

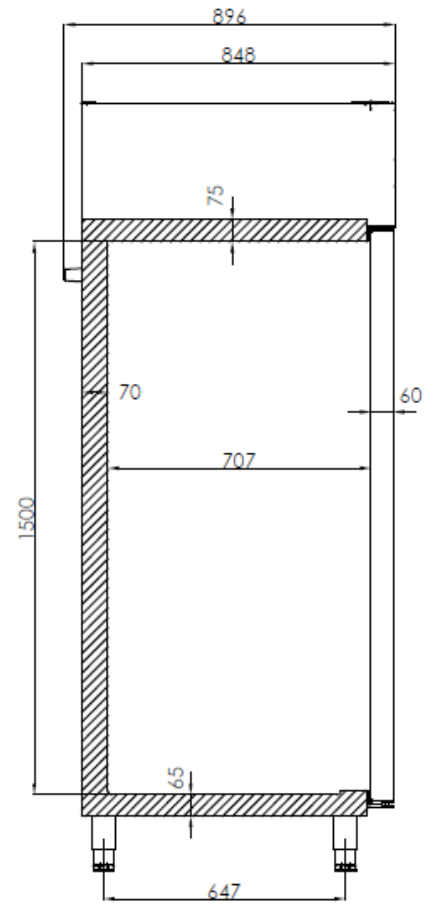
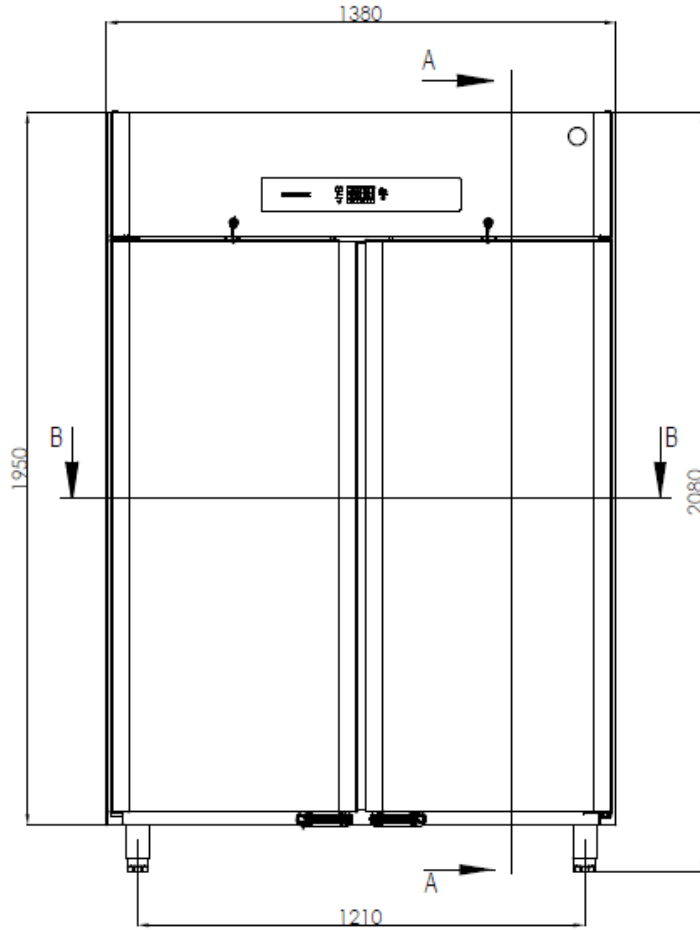

A-A

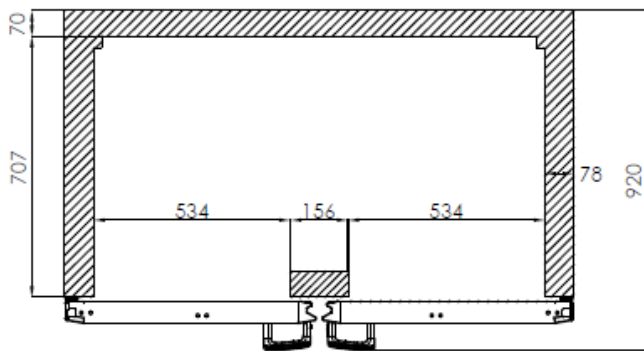

B-B

HOSHIZAKI

Premier Remote Cabinets



BAKER U 950

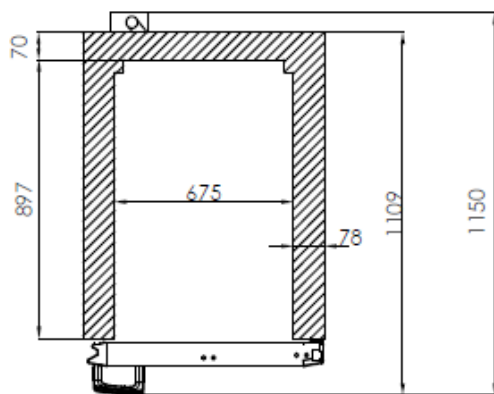
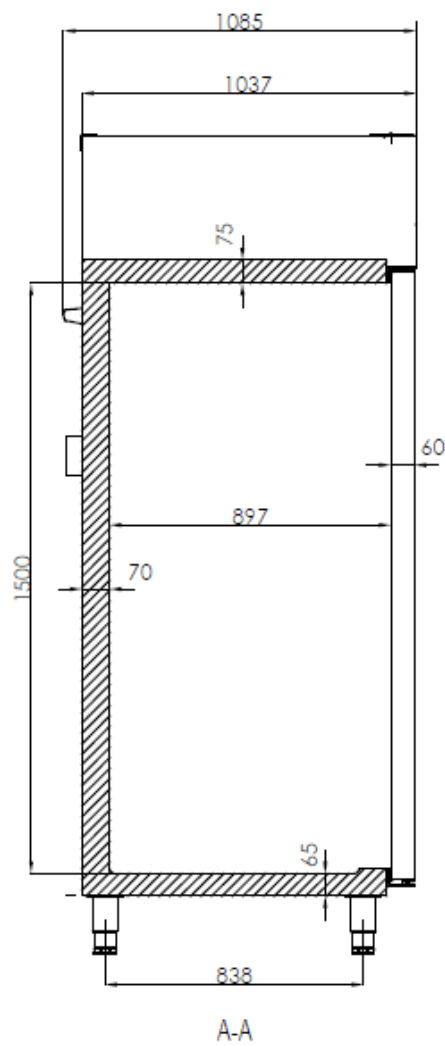
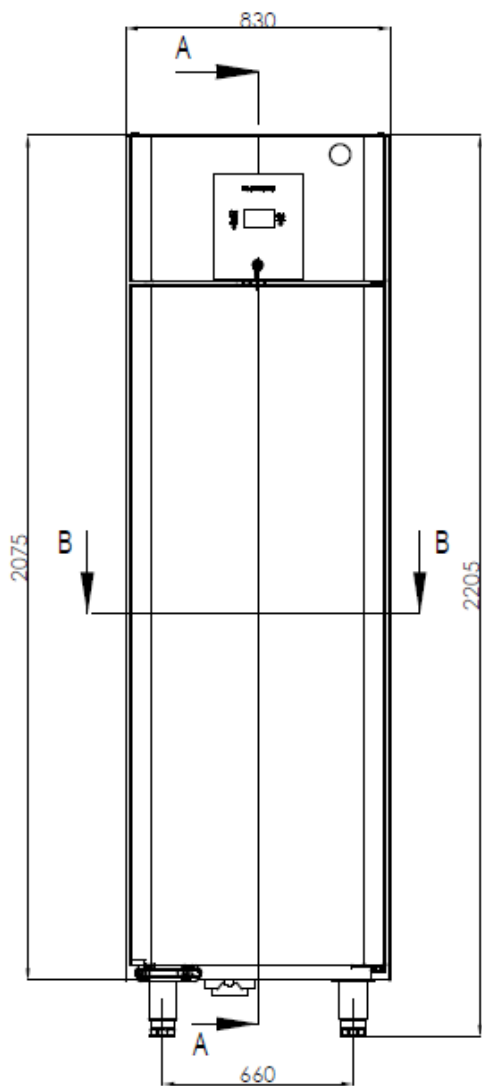

HOSHIZAKI

Premier Remote Cabinets



BAKER GA 950 (RU1)

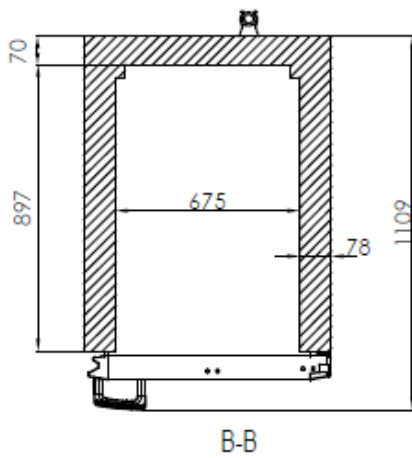
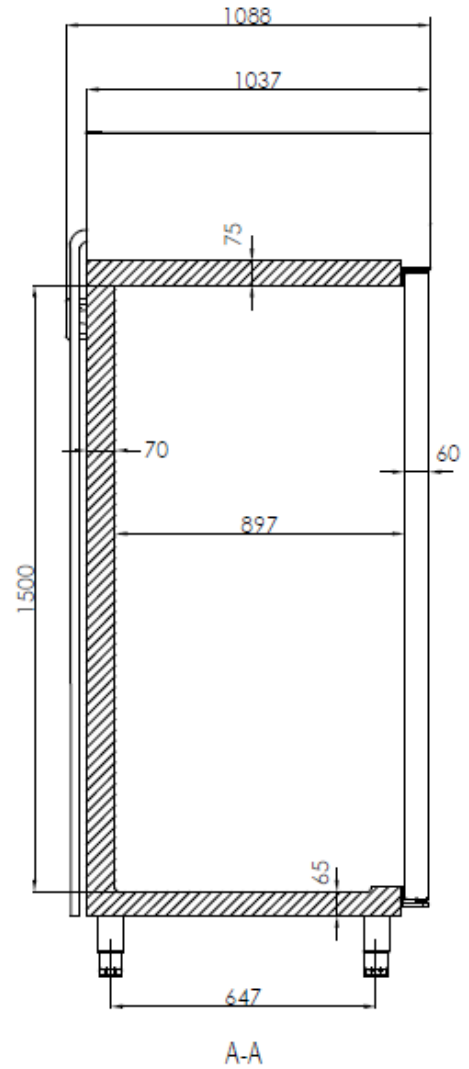
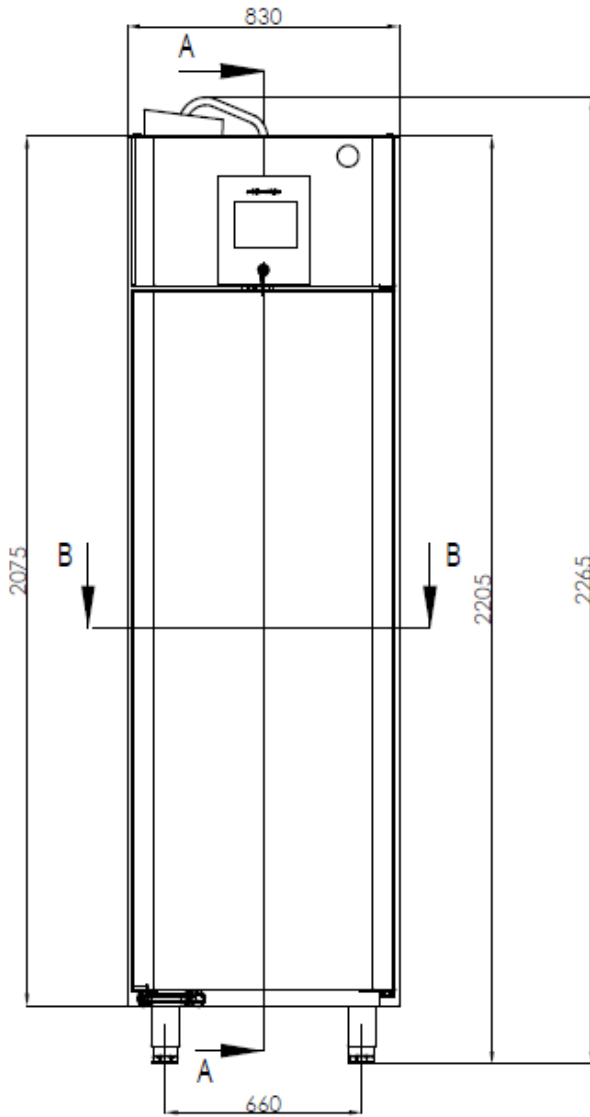

HOSHIZAKI

Premier Remote Cabinets



BAKER SF 950 (RU1)

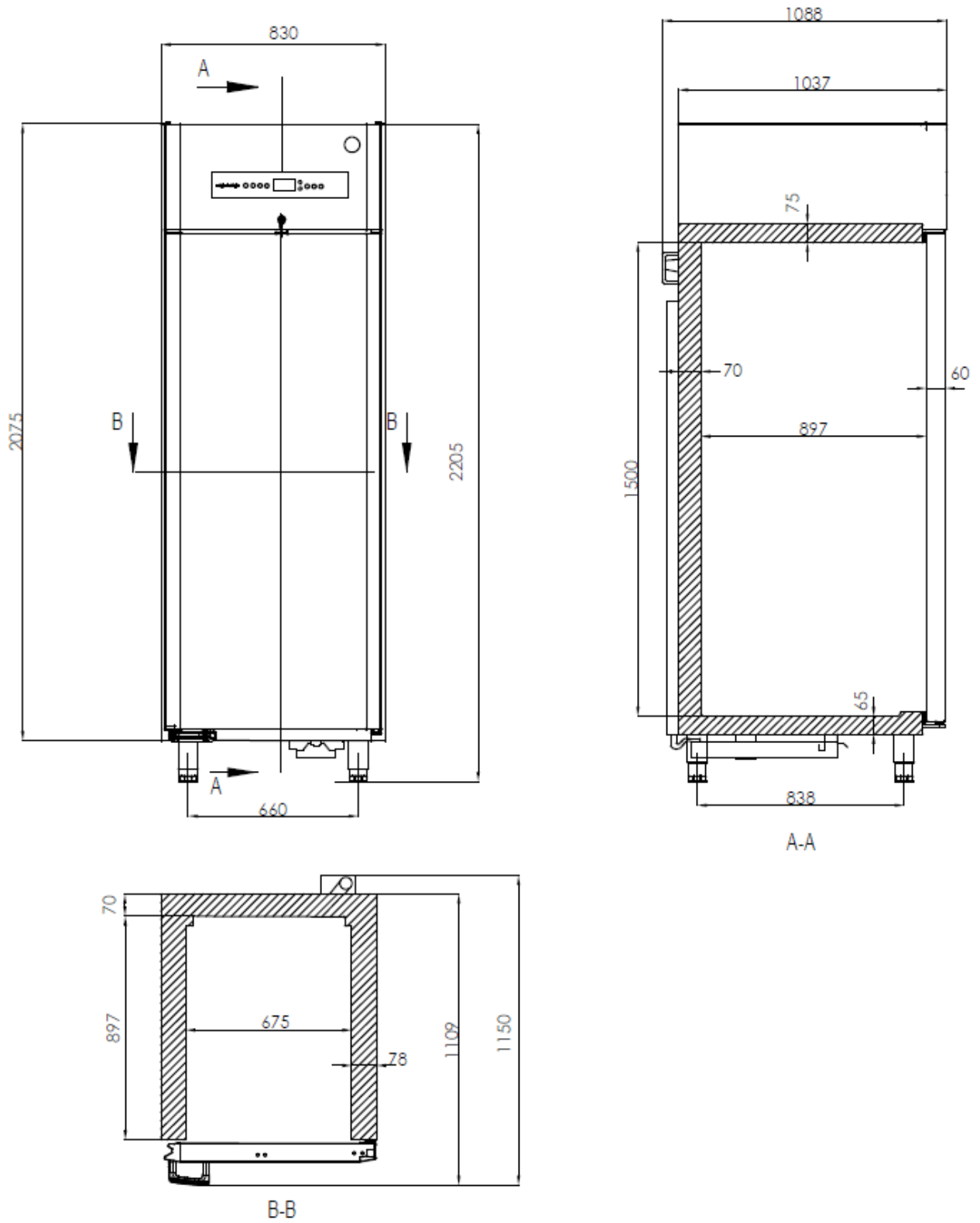



Disposal

The below only concerns the United Kingdom.

Disposal of an old cabinet is only available when we are delivering a new one at the same time. Cabinets must be fully defrosted and emptied prior to collection.

Hoshizaki recognizes that our products for the catering market are considered as WEEE when they become obsolete. To ensure that Hoshizaki's responsibilities are handled correctly and environmentally friendly, we are signed up the largest Business to Business compliance scheme in the UK – B2B Compliance
<http://www.b2bcompliance.org.uk>

B2B Compliance will on our behalf deal with all areas of our responsibilities when collecting and disposing of equipment which fall under the UK WEEE regulations. B2B Compliance can be contacted on telephone number 01691 676124.





Electrical Wiring Diagrams

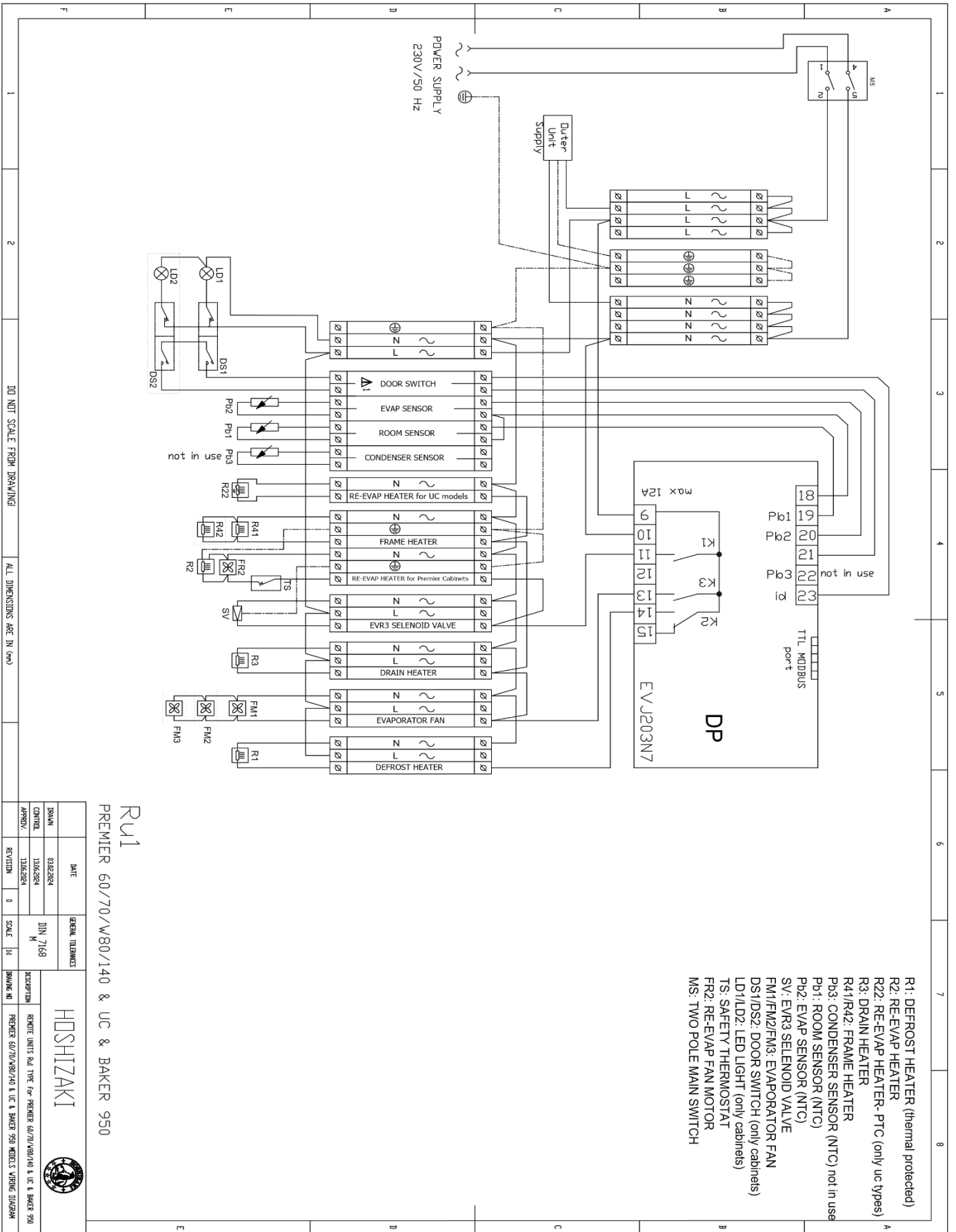

Ru1

PREMIER 60/70/W80/140 & UC & BAKER 950

DATE	GENERAL DIMENSIONS	DESCRIPTION
03/02/2024	DIN 7168	REMOTE UNITS RUL TYPE for PREMIER 60/70/W80/140 & UC & BAKER 950
13/06/2024	H	PREMIER 60/70/W80/140 & UC & BAKER 950 MODELS WIRING DIAGRAM
13/06/2024	0	



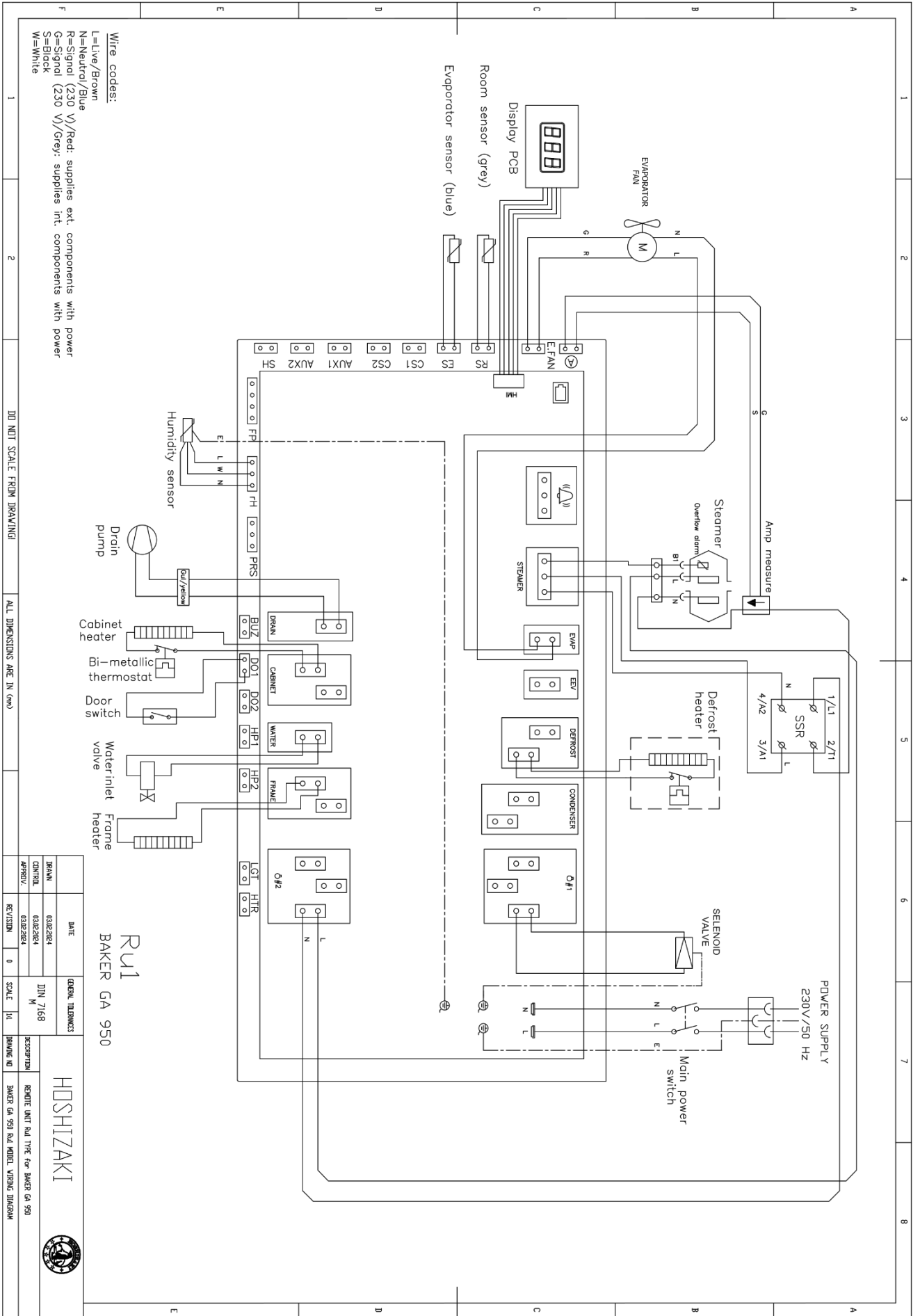

HOSHIZAKI

Premier Remote Cabinets

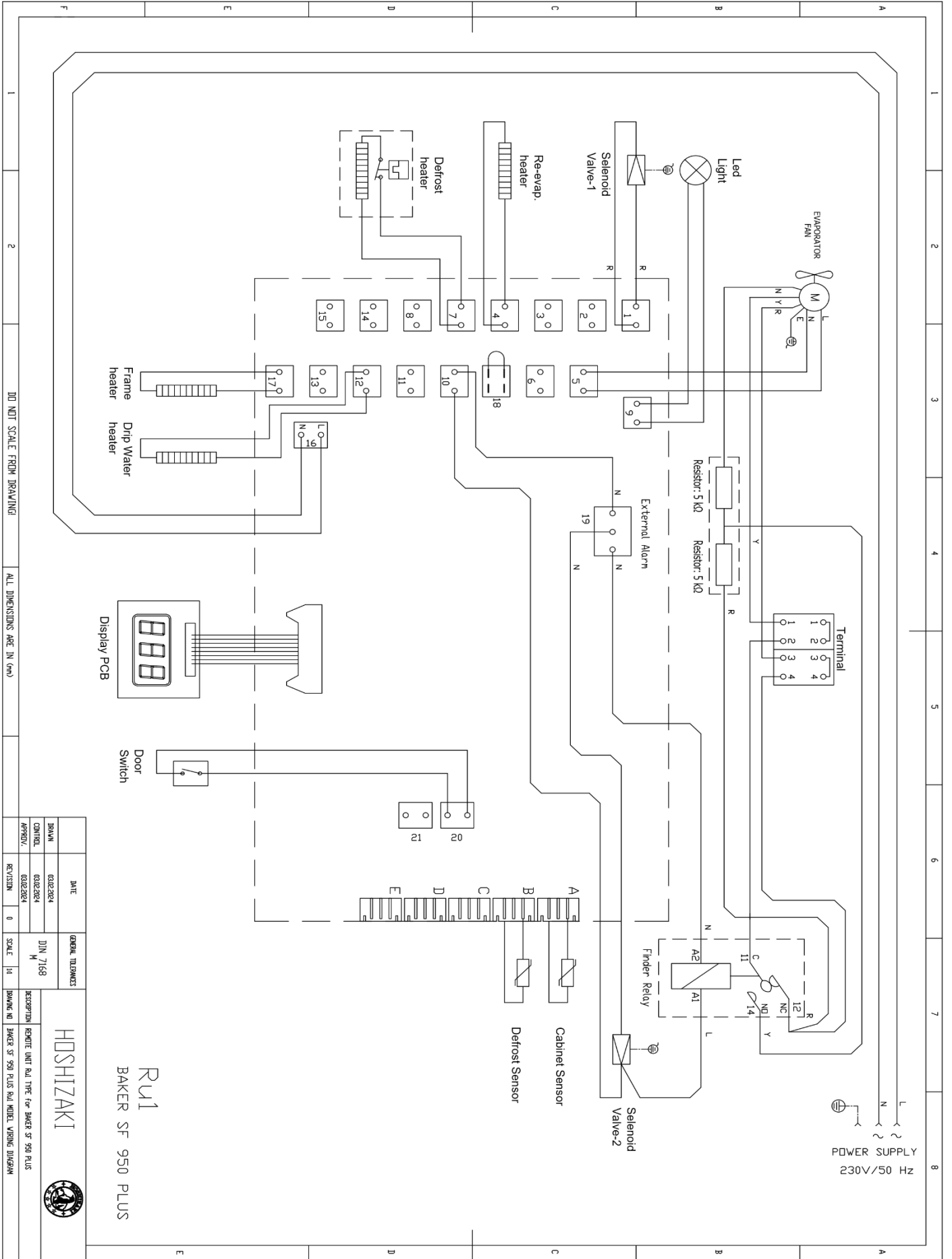

RUI
 BAKER SF 950 PLUS

DO NOT SCALE FROM DRAWING
 ALL DIMENSIONS ARE IN (mm)

GENERAL INFORMATION		DATE	
DESIGNER	03022024	DATE	03022024
CONTROL	03022024	REVISION	0
APPROV.		SCALE	1:1

HOSHIZAKI



RECEPTION NO. BAKER SF 950 PLUS
 DRAWING NO. BAKER SF 950 PLUS

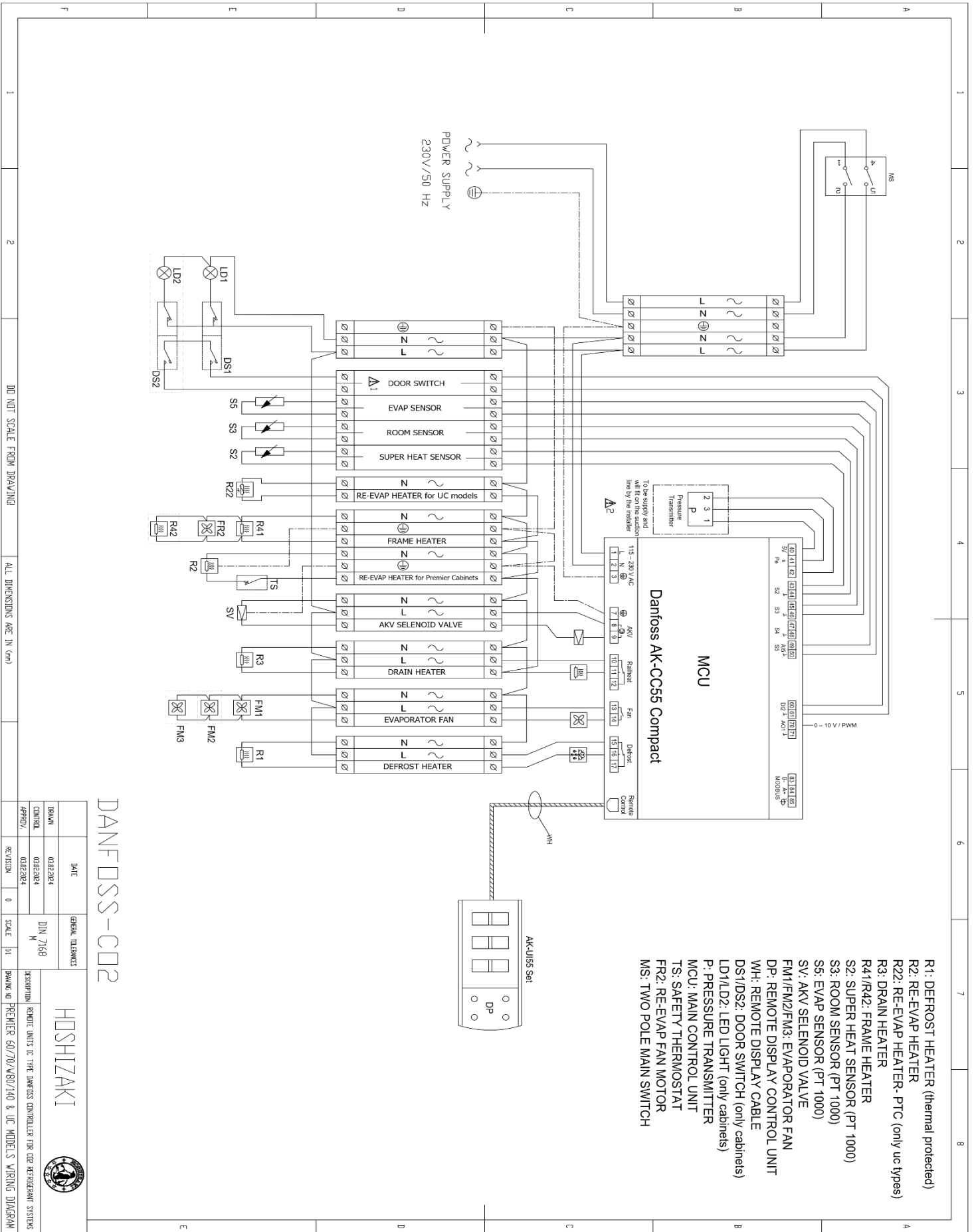

DANFOSS-CC2

DATE	03.02.2024	GENERAL TOLERANCES	DIN 7168
DRAWN	03.02.2024		
CONTROL	03.02.2024		
APPROV.	03.02.2024		
REVISION	0	SCALE	1:1
DRAWING NO: PREMIER 60/70/80/140 & UC MODELS WIRING DIAGRAM		DESCRIPTION: REMOTE UNITS TO THE DANFOSS CONTROLLER FOR CO2 REFRIGERANT SYSTEMS	

HOSHIZAKI



HOSHIZAKI Premier Remote Cabinets

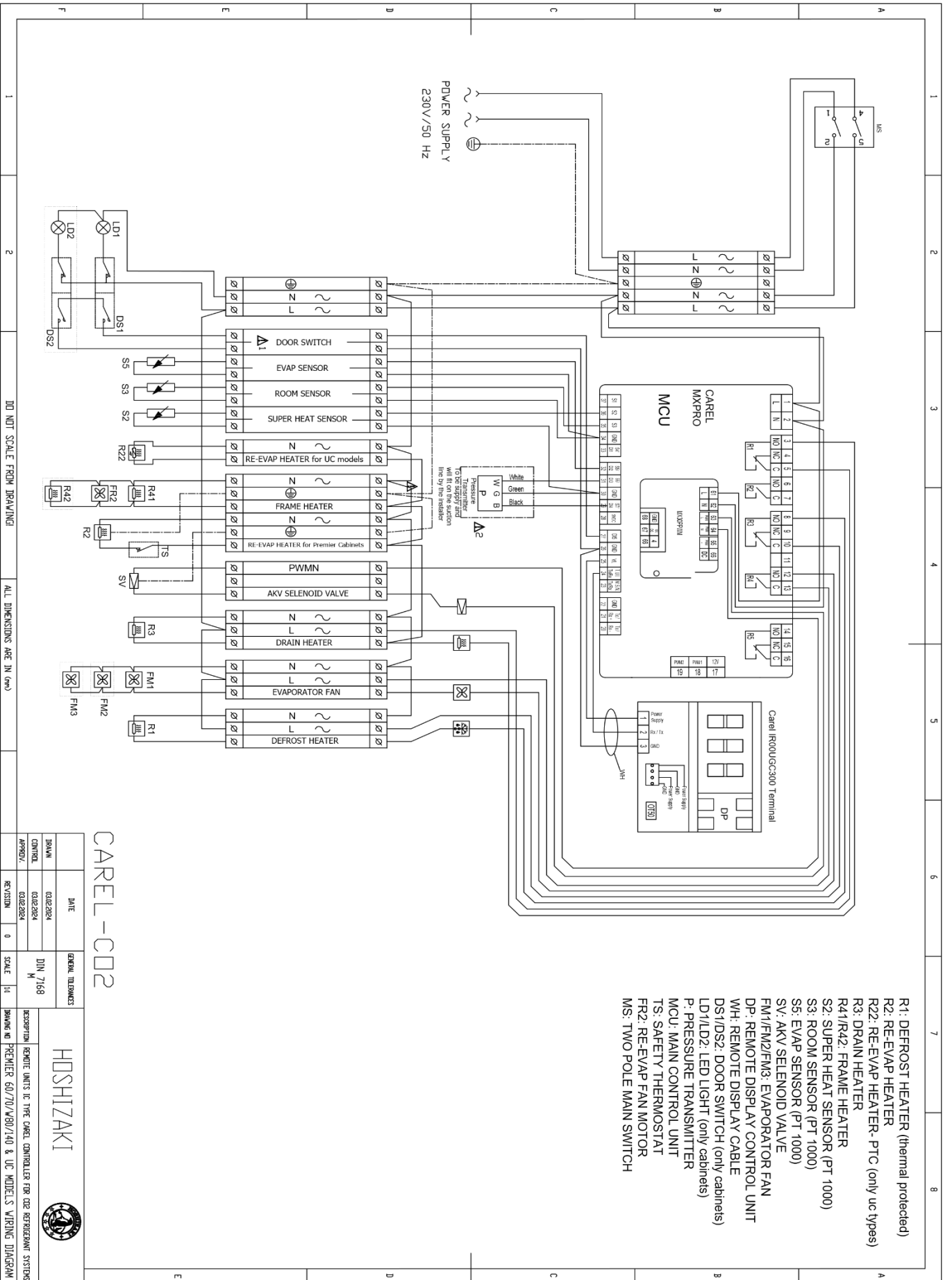

- R1: DEFROST HEATER (thermal protected)
- R2: RE-EVAP HEATER
- R22: RE-EVAP HEATER- PTC (only uc types)
- R3: DRAIN HEATER
- R41/R42: FRAME HEATER
- S2: SUPER HEAT SENSOR (PT 1000)
- S3: ROOM SENSOR (PT 1000)
- S5: EVAP SENSOR (PT 1000)
- SV: AKV SELENOID VALVE
- FM1/FM2/FM3: EVAPORATOR FAN
- DP: REMOTE DISPLAY CONTROL UNIT
- WH: REMOTE DISPLAY CABLE
- DS1/DS2: DOOR SWITCH (only cabinets)
- LD1/LD2: LED LIGHT (only cabinets)
- P: PRESSURE TRANSMITTER
- MCU: MAIN CONTROL UNIT
- TS: SAFETY THERMOSTAT
- FR2: RE-EVAP FAN MOTOR
- MS: TWO POLE MAIN SWITCH

1 2 3 4 5 6 7 8

DO NOT SCALE FROM DRAWING ALL DIMENSIONS ARE IN (mm)

CAREL-C02

DATE	GENERAL TOLERANCES	HOSHIZAKI
03/02/2024	DIN 7168	
03/02/2024	M	
03/02/2024	0	
SCALE 1:1	REVISION	DESCRIPTION: REMOTE UNITS IC TYPE CAREL CONTROLLER FOR CO2 REFRIGERANT SYSTEMS DRAWING NO: PREMIER 60/70/W80/140 & UC MODELS WIRING DIAGRAM

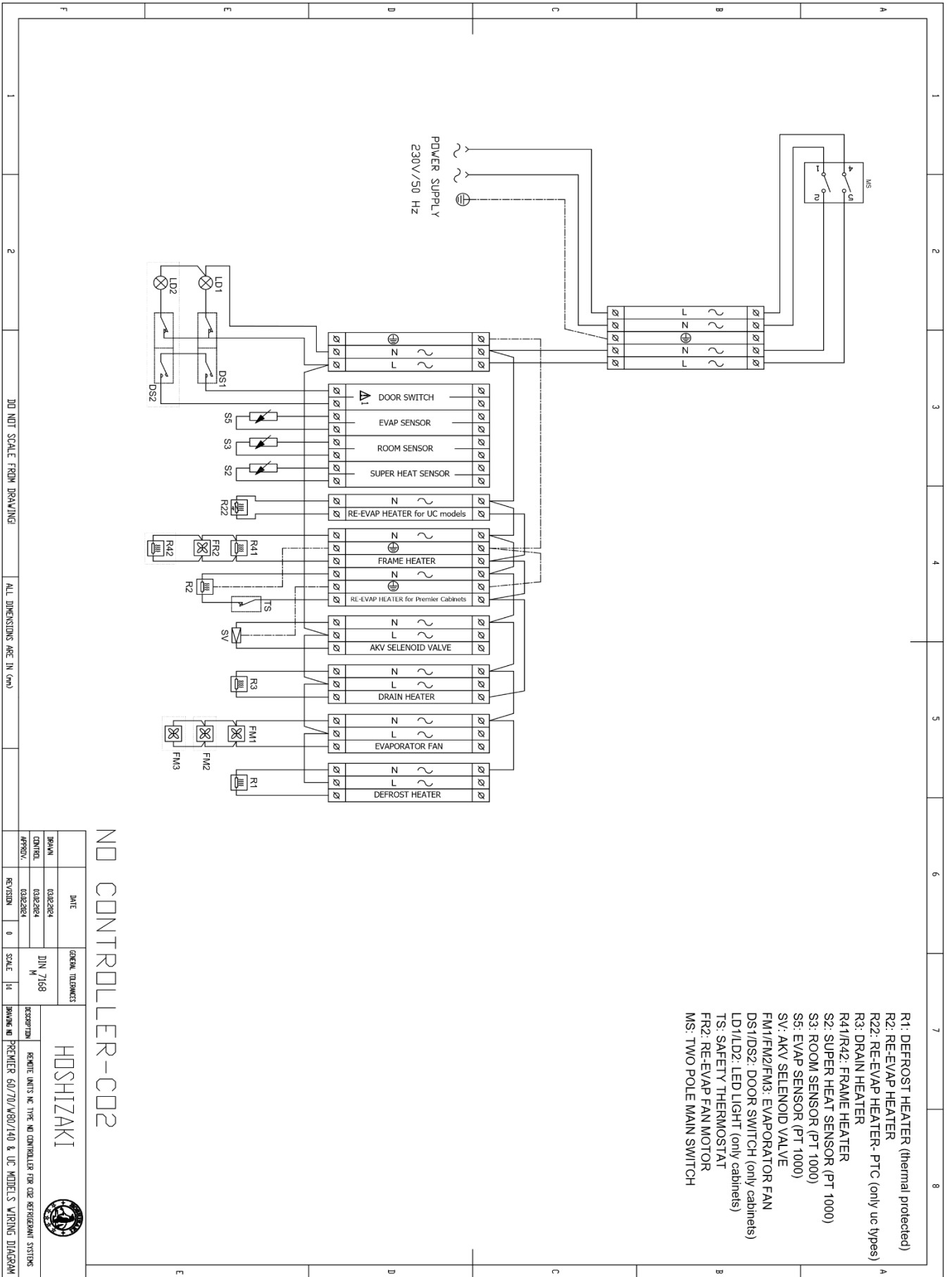

- R1: DEFROST HEATER (thermal protected)
- R2: RE-EVAP HEATER
- R22: RE-EVAP HEATER- PTC (only uc types)
- R3: DRAIN HEATER
- R41/R42: FRAME HEATER
- S2: SUPER HEAT SENSOR (PT 1000)
- S3: ROOM SENSOR (PT 1000)
- S5: EVAP SENSOR (PT 1000)
- SV: AKV SELENOID VALVE
- FM1/FM2/FM3: EVAPORATOR FAN
- DS1/DS2: DOOR SWITCH (only cabinets)
- LD1/LD2: LED LIGHT (only cabinets)
- TS: SAFETY THERMOSTAT
- FR2: RE-EVAP FAN MOTOR
- MS: TWO POLE MAIN SWITCH

NO CONTROLLER-C02

DATE		GENERAL THICKNESS		HOSHIZAKI	
DESIGN	03/28/2014	DIN 7168			
CONTROL	03/28/2014	M			
APPROV.	03/28/2014	SCALE: 1:1			
REVISION	0			DRAWING NO: PREMIER 60/70/W80/140 & UC MODELS WIRING DIAGRAM	

DO NOT SCALE FROM DRAWING

ALL DIMENSIONS ARE IN (mm)



Cooling Diagrams

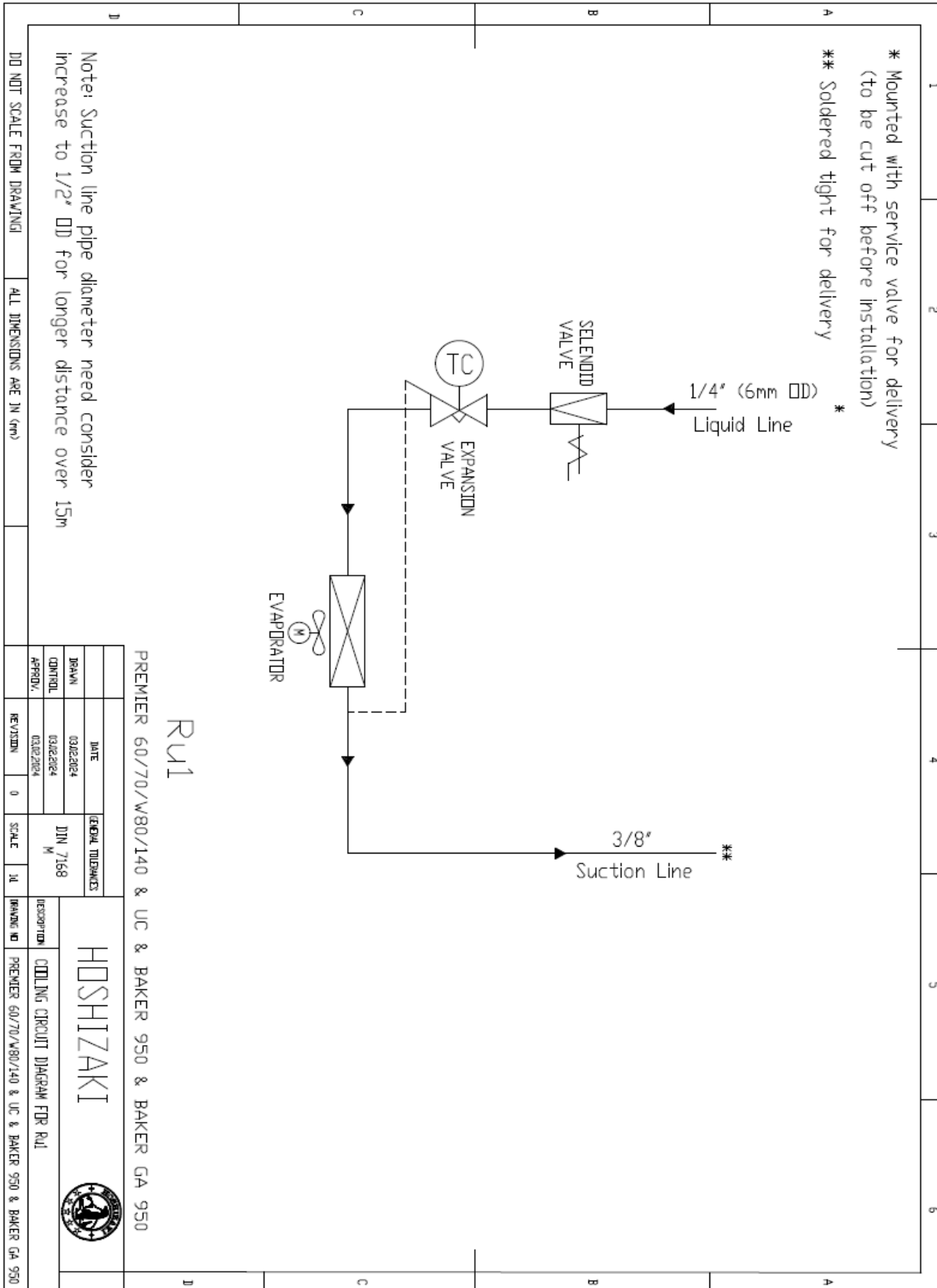

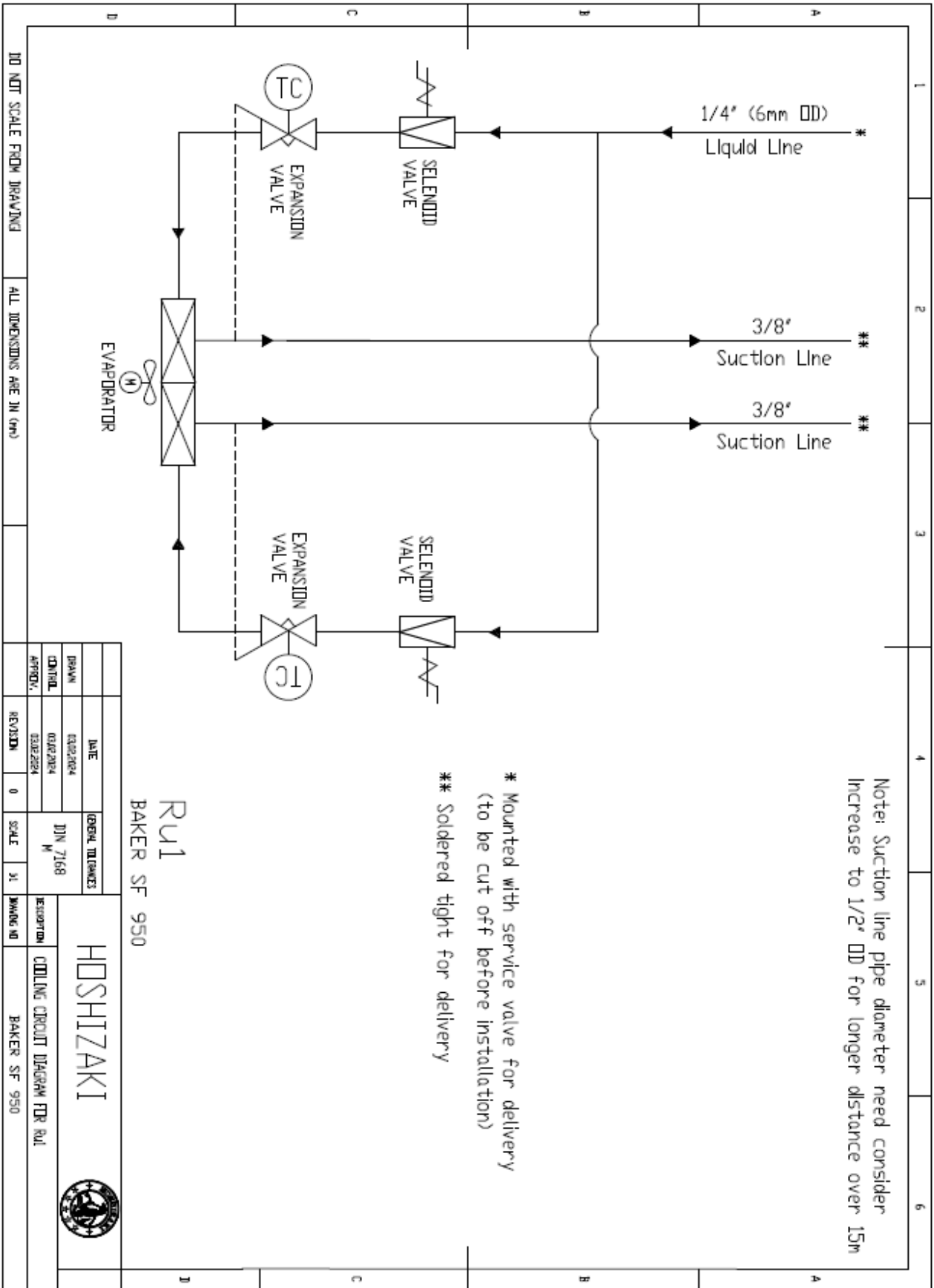

HOSHIZAKI Premier Remote Cabinets

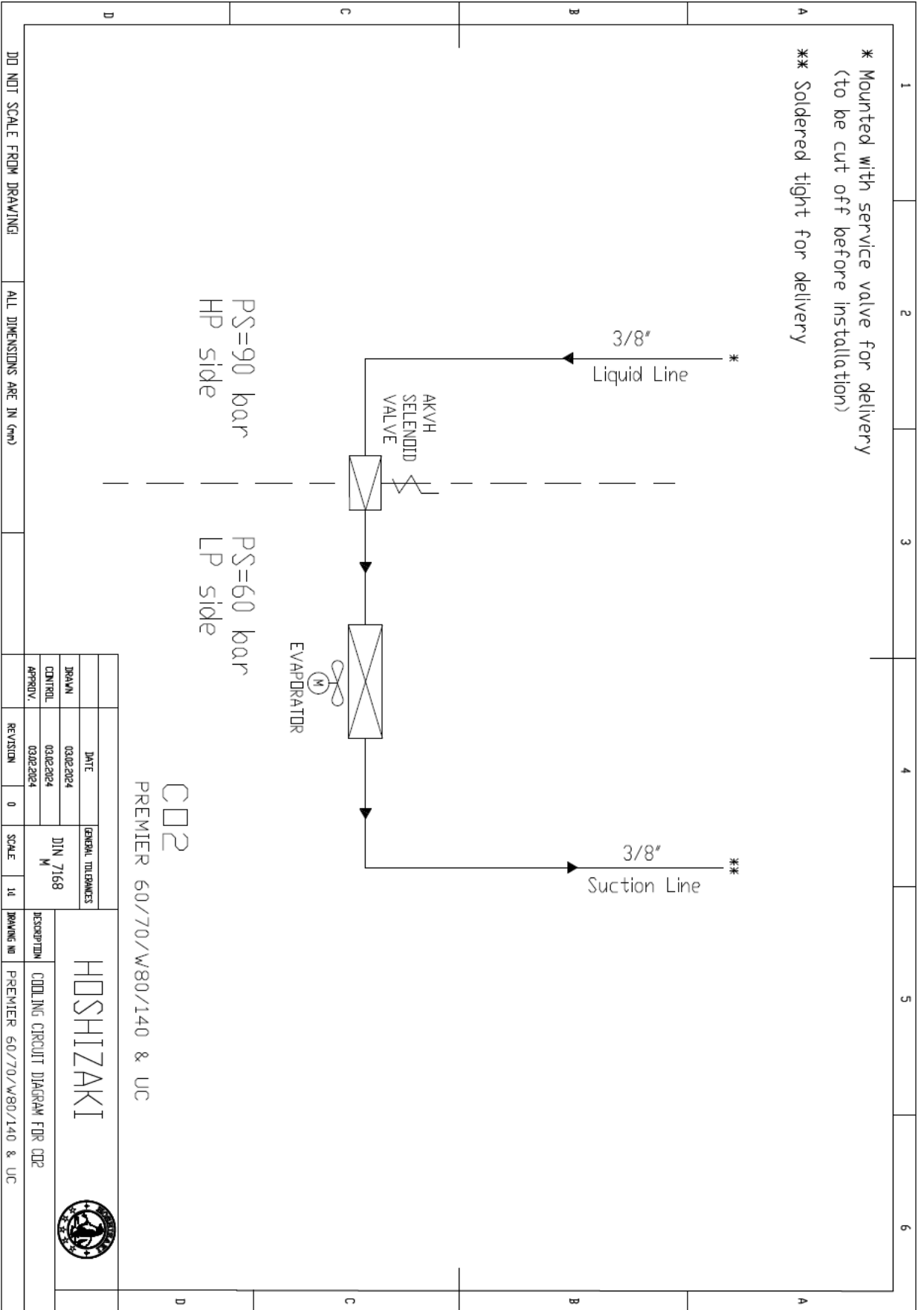



All Rights Reserved

Hoshizaki reserves the right to change any features and the information in this manual.

Contact Details

Headquarters

Hoshizaki Europe B.V.

TEL: +31 20 691

8499

Sales@hoshizaki.nl

<http://hoshizaki->

[europe.com/](http://hoshizaki-europe.com/)

Branches

Hoshizaki UK - UK, Ireland

TEL: +44 845 456 0585

uksales@hoshizaki.co.uk

Hoshizaki Deutschland - Germany, Switzerland, Austria

TEL: +49 2154 92810, +49 5066 604612

info@hoshizaki.de

Hoshizaki BENELUX - Netherlands, Belgium, Luxembourg

TEL: +31 20 565 0420, +31 54 645 4252

sales@hoshizaki.nl

Hoshizaki France - France

TEL: +33 1 48 63 93 80

info@hoshizaki.fr

Hoshizaki Iberia - Spain, Portugal

TEL: +34 93 478 09 52

info@hoshizaki.es

Hoshizaki Middle East - Middle East

TEL: +971 48 876 612

sales@hoshizaki.ae

Hoshizaki Danmark – Denmark, Norway, Sweden

TEL: +45 8988 5350

salg@hoshizaki.dk

Hoshizaki Europe B.V – All other countries in Europe and Africa

TEL: +31 20 565 0420

sales@hoshizaki.nl



MODELES RU1 & CO2 COMMANDES A DISTANCE MANUEL D'INSTALLATION, D'UTILISATION ET D'ENTRETIEN



Contact : HOSHIZAKI EUROPE B.V.

Adresse : Burgemeester Stramanweg 101 1101 AA Amsterdam, Pays-Bas

Tél. : +31 (0)20 691 84 99 - <http://hoshizaki-europe.com/>





Contenu

Application.....	45
Informations Relatives à La Sécurité	46
Emplacement.....	47
Raccordement Electrique	49
Utilisation Générale	50
Utilisation du Produit (contrôleur Evco - Modèle RU1)	51
Utilisation du Produit (Contrôleur Danfoss AK - CC55)	52
Utilisation du Produit (contrôleur Carel MPXpro)	55
Utilisation du Produit NC (pas de contrôleur – modèle).....	61
Dépannage.....	61
Eau de Dégivrage.....	62
Mécanisme de Fermeture de Porte	62
Panne de Courant	62
Nettoyage	62
Joint de Porte.....	63
Remisage à Long Terme	63
Réparations	63
Données Techniques.....	64
Dimensions.....	66
Mise au Rebut	73
Schémas Electriques.....	74
Schémas de Refroidissement.....	80



Merci d'avoir choisi un produit de qualité de la marque Hoshizaki.

Ce manuel vous explique comment installer, utiliser et entretenir votre nouveau produit.

Avant de quitter l'usine, nos produits sont soumis à un test de fonctionnement et de qualité complet. Si vous rencontrez néanmoins des problèmes avec le produit, contactez votre revendeur local.

Les filiales et revendeurs Hoshizaki implantés dans le monde entier sont prêts à vous aider.

Les produits fabriqués par Hoshizaki sont couverts par différentes conditions de garantie liées au pays dans lequel le produit est vendu.

Cette garantie est sous réserve d'une utilisation correcte conforme aux spécifications, p. ex. lorsque l'entretien courant et les réparations éventuelles sont effectués par des techniciens désignés par le revendeur et avec une connaissance générale du produit.

Toute modification de l'installation et toute autre utilisation du produit par rapport aux spécifications de ce manuel risquent d'affecter le fonctionnement et la durabilité du produit.

Le manuel est rédigé en fonction de nos connaissances techniques actuelles. Nous travaillons constamment à la mise à jour de ces informations et nous nous réservons le droit d'apporter des modifications techniques.

Application

Le produit est destiné au stockage de denrées alimentaires dans des environnements non domestiques.

Le produit est conçu pour le stockage à température constante et ne peut pas être utilisé pour refroidir ou congeler des aliments chauds/frais.

Le produit ne peut être utilisé qu'aux fins pour lesquelles il a été expressément conçu. Toute autre utilisation risquerait d'entraîner un mauvais maintien de la température des denrées alimentaires stockées, voire d'endommager le produit.

Le produit n'est pas adapté au stockage de plasma sanguin, d'échantillons de laboratoire, de produits pharmaceutiques ou de substances similaires.

Le fabricant décline toute responsabilité pour les dégâts provoqués par une utilisation inappropriée, incorrecte ou abusive du produit.

Informations Relatives à La Sécurité

Important

Description des symboles utilisés dans ce manuel.



Avertissement Le non-respect de ces instructions peut entraîner des blessures corporelles.



Important Si ces instructions ne sont pas respectées, le produit risque d'être endommagé ou détruit.

Soyez conscient que Hoshizaki a pris des précautions pour s'assurer de la sécurité du produit.

Veillez lire attentivement les informations suivantes concernant la sécurité.



Il est important que tous ceux qui doivent utiliser ou installer le produit aient accès à ce manuel.



Cet appareil n'a pas été conçu pour être utilisé par des personnes aux capacités physiques, sensorielles ou mentales réduites, ni par des personnes dont l'expérience et les connaissances sont limitées, sauf si elles sont sous la surveillance d'une personne responsable de leur sécurité ou que celle-ci leur a donné des instructions relatives à l'utilisation de l'appareil.



Surveiller les enfants pour éviter qu'ils ne jouent avec l'appareil.



Il est possible que des parties de l'appareil présentent des arêtes coupantes dans le compartiment du compresseur et dans le compartiment intérieur.



L'appareil ne doit pas être transporté sur un diable, il existe un risque de perte d'équilibre, ce qui peut se révéler dangereux pour les personnes.



Ne tirez pas sur le cordon d'alimentation pour débrancher l'appareil ou lors de son déplacement.

Emplacement

A la réception du produit, vérifiez que le matériau d'emballage n'est pas endommagé.

En cas d'endommagement du matériau d'emballage, il convient de déterminer si le produit a été endommagé. Si les dommages sont importants, veuillez contacter votre revendeur.



Cette tâche nécessite au moins 2 personnes. La partie la plus lourde du produit se trouve en haut. Tenez-en compte lors du retrait du produit de la palette de transport.



En raison du poids élevé du produit, le sol peut être endommagé ou rayé lors de son déplacement.



Une configuration correcte permet un fonctionnement optimal.



Le produit doit être installé dans une pièce sèche et correctement ventilée.



Pour garantir un fonctionnement efficace, il ne doit pas être exposé à la lumière directe du soleil ou installé contre des surfaces émettrices de chaleur. Le produit est conçu pour fonctionner à une température ambiante comprise entre +16 °C et +40 °C.



Evitez de placer le produit dans un environnement contenant du chlore ou de l'acide (piscine, etc.) en raison du risque de corrosion.



Le produit et certaines parties du compartiment intérieur sont recouverts d'un film de protection, qui doit être retiré avant utilisation.



Nettoyez l'armoire avec une solution savonneuse douce avant utilisation.

L'emplacement d'installation doit être horizontal et de niveau.

Pour les versions montées sur pieds, utilisez les pieds réglables pour vous assurer que le produit est droit et de niveau.

Pour les versions montées sur roulettes, les dispositifs de verrouillage des deux roulettes avant doivent être actionnés lorsque le produit est en place.

HOSHIZAKI

Premier Remote Cabinets



Il doit toujours y avoir 500 mm d'espace libre au-dessus du produit pour permettre les réparations. Le produit doit être placé le plus près possible du mur.

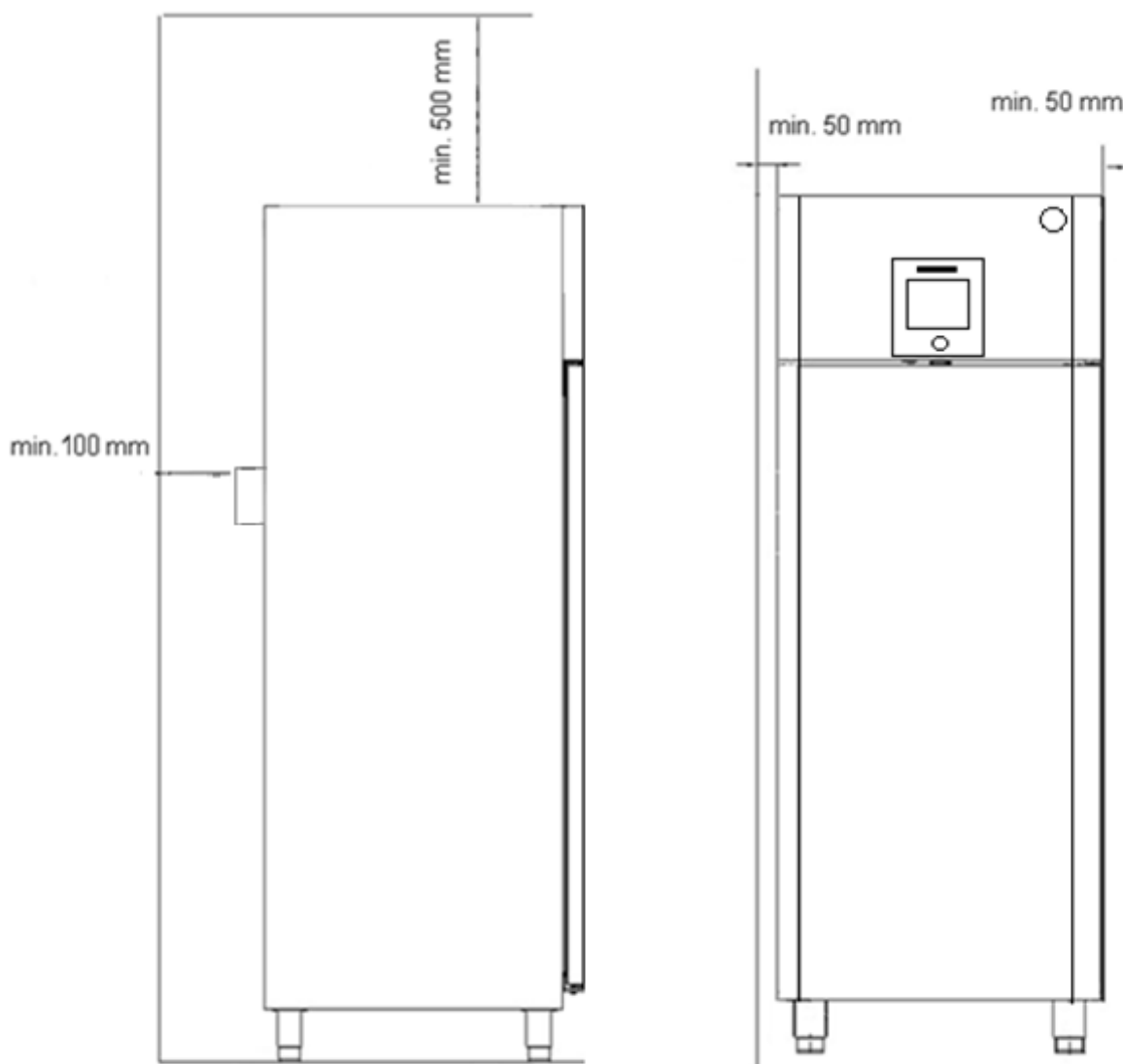

Raccordement Electrique

Veillez lire attentivement le texte ci-dessous avant tout raccordement électrique.



Le produit est destiné à être raccordé à un courant alternatif. La tension de raccordement (V) et la fréquence (Hz) sont indiquées sur la plaque signalétique de l'armoire.



N'utilisez jamais de rallonge pour cet appareil !

Si une prise murale est installée à une distance supérieure à la longueur du cordon d'alimentation fourni, contactez un électricien pour poser une prise murale à portée du cordon d'alimentation.



Si le produit est défectueux, **il doit être examiné par un technicien d'entretien qualifié**, familiarisé avec l'unité de commande installée et expérimenté dans l'entretien de l'armoire modèle CO2.



En règle générale, le produit doit être examiné par la société qui l'a branché.



Débranchez toujours le produit en cas de coupure d'alimentation, de démontage/mise sous tension des composants électriques et avant de nettoyer et d'entretenir le produit.



N'utilisez pas le produit si les pièces de protection ne sont pas toutes installées, afin d'éviter tout contact avec des pièces de la machine sous tension ou en rotation.

Le produit ne doit pas être utilisé à l'extérieur.



Toutes les exigences de mise à la terre prescrites par les autorités locales en matière d'électricité doivent être respectées. La fiche et la prise murale doivent alors assurer une mise à la terre correcte. Consultez un électricien si nécessaire.



Assurez-vous que l'appareil est mis hors tension au niveau de la prise ou que la fiche côté appareil du cordon d'alimentation est débranchée avant d'effectuer l'entretien des composants électriques. Il ne suffit pas d'éteindre le produit au niveau du contrôleur.

Utilisation Générale



Veillez à ne pas endommager les pièces du système de réfrigération.



Si le produit est équipé d'un plateau de réévaporation sous l'armoire, il est important de ne pas entretenir/nettoyer le plateau ou le dispositif de chauffage avant que l'armoire n'ait été mise hors tension suffisamment longtemps pour s'assurer que le dispositif de chauffage de réévaporation s'est refroidi, afin de prévenir les risques de brûlures.



N'utilisez pas d'appareils électriques à l'intérieur du produit.



Pour garantir un débit d'air correct et efficace dans l'armoire, ne placez aucun article dans les zones indiquées sur l'illustration.



Tous les articles à stocker, s'ils ne sont pas enveloppés ou emballés, doivent être recouverts afin d'éviter la corrosion des composants internes de l'armoire.



Si des paramètres par défaut du contrôleur sont modifiés, cela peut entraîner un dysfonctionnement du produit, et des températures incorrectes risquent d'endommager les articles à l'intérieur.



Charge maximale de la clayette : 40 kg

N'entreposez pas dans cet appareil des substances explosives telles que des bombes aérosols utilisant un gaz propulseur inflammable.



Ne placez aucun produit sous le support de la clayette inférieure ou au-dessus de la ligne de charge supérieure.

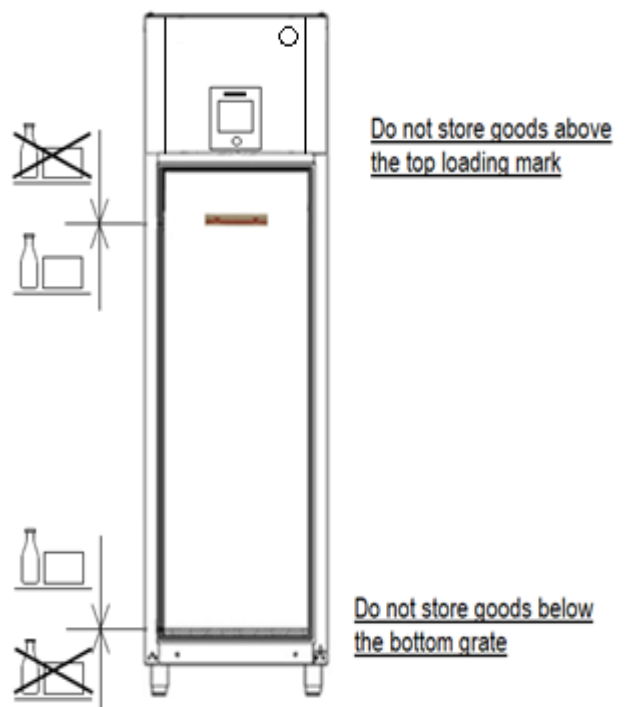

Utilisation du Produit (contrôleur Evco - Modèle RU1)

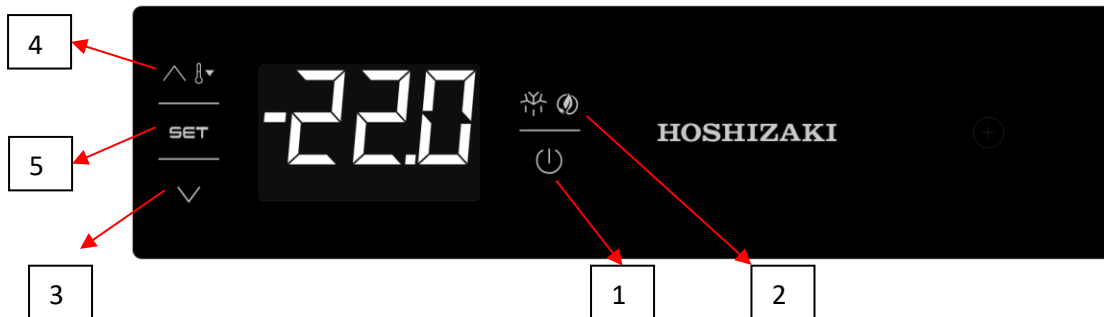

➤ FONCTIONS DU PANNEAU AVANT

Pour verrouiller les touches du panneau avant, maintenir enfoncées les touches AUX (3) et Marche/Veille (1) pendant 2 secondes : le texte « Loc » s'affiche à l'écran lorsque les touches sont verrouillées, le texte « UnL » s'affiche si elles ne sont pas verrouillées.

1) Lorsque la touche **Marche/Veille** est maintenue enfoncée pendant quatre secondes ; l'appareil s'ouvre ou se ferme. (Marche/Arrêt)

2) **DEGIVRAGE MANUEL** : si la touche est enfoncée pendant quatre secondes, le dégivrage manuel commence. En cas de refroidissement excessif et si la température de l'évaporateur n'est pas adaptée, le dégivrage manuel ne commence pas.

3) Touche **BAS** : pour faire défiler le menu vers le bas ou réduire la valeur ; si la touche est maintenue enfoncée pendant quatre secondes, le refroidissement extrême s'active. Lorsque la fonction de refroidissement en cours est excessive, la température définie peut être réduite ; la durée et la température sont déterminées à l'aide des paramètres. Lorsqu'une fonction de refroidissement excessive est activée, l'appareil ne dégivre jamais.

4) Touche **HAUT** : pour faire défiler le menu vers le haut ou augmenter la valeur ; si la touche est maintenue enfoncée pendant quatre secondes, la fonction de pourcentage faible et élevé d'humidité relative est activée. (Sur certains modèles) « rhL » s'affiche à l'écran (la fonction de faible pourcentage d'humidité relative est utilisée) ou « rhH » s'affiche (la fonction de pourcentage élevé d'humidité relative est utilisée). Ces fonctions s'affichent à l'écran pendant 10 secondes. Si le contrôle de l'humidité n'est pas disponible, « ---- » s'affiche à l'écran pendant 1 seconde.

5) Touche **SET** : touche de saisie et de modification pour les valeurs réglables.

➤ FONCTIONNEMENT

Des exemples d'utilisation sont décrits ci-dessous :

Etat « **Marche** » : l'appareil est sous tension et fonctionne.

Etat « **En veille** » : l'appareil est hors tension, mais il est toujours alimenté.

Etat « **Arrêt** » : pour mettre l'appareil hors tension, retirez la fiche de la prise ou désactivez le fusible de l'alimentation principale.

Utilisation du Produit (Contrôleur Danfoss AK - CC55)

Mise en marche :

Branchez l'appareil.

Assurez-vous que l'interrupteur principal bipolaire est activé.

Explication de l'affichage (AK-UI55) :

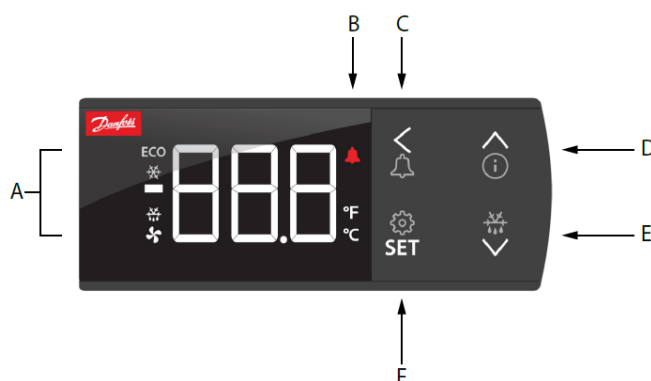

Pièces d'affichage	Description
A	S'allume dans les cas suivants :  <ul style="list-style-type: none"> - Optimisation énergétique (ECO) - Refroidissement - Dégivrage - Fonctionnement du ventilateur
B	S'allume en cas d'alarme
C	Appuyez longuement (3 secondes) sur le bouton d'alarme (le relais est réinitialisé) pour afficher le code d'alarme
D	Une pression longue (3 secondes) permet d'accéder au menu d'informations « InF » (Veuillez vous référer à la figure « b ») Flèche haut / Flèche bas / Flèche vers la gauche : navigation dans le menu et définition des valeurs.
E	Une pression longue (3 secondes) déclenche le dégivrage, et le symbole « -d- » s'affiche. Un dégivrage en cours peut être arrêté par une pression longue.
F	SET : Une pression longue (3 secondes) permet d'accéder au menu « SET ». Si l'opération est verrouillée par un mot de passe, « PS » est affiché. Saisissez le code. * Affiche le réglage sélectionné / enregistre un réglage modifié. Une pression courte permet d'accéder à la limite de coupe-circuit du thermostat.

* Le réglage d'usine de P89 est « 0 », cette étape sera ignorée sans aucune valeur d'entrée.



a - Liste des paramètres du bouton « SET »

SET	←	SET button, 3 s: Configuration settings
Set		
(PS) v	←	PS: Password (if any)
cFg	SET →	
v		
r--		
A--		
c--		
d--		
n--		
F--		
t--		
h--		
o--		
p--		
q--		
u--		
<		
(Return)		

r12	Main switch
o61	Application
o03	MODBUS address
r89	Food type
r00	Cut-out temperature
r15	Ther. sensor S4 %
r61	Ther. sensor S4% night
A36	Alarm sensor S4%
o17	Display air S4%
o30	Refrigerant type
o20	Min. transmitter range
o21	Max. transmitter range
d01	Defrost method
d03	Defrost interval
d10	Defrost sensor
d04	Max. defrost time
d02	Defrost stop temperature
<	
(Return)	

Menu groups
See also the following pages.

b - Liste des paramètres du bouton « Info »

^	←	Info button, 3 s: Information for service use
Inf		
StA	SET	See control state message
App	SET	See selected application
in	SET →	
out	SET →	
buS	SET	MODBUS quality
SoF	SET	See SW version
<		
(Return)		

do1	*	Read output status
do2	*	
do3	*	
do4	*	
Ao1	**	
<		(Return)

Al1	(PE)	Read input status
Al2	**	
Al3	**	
Al4	**	
Al5	**	
di1	**	
di2	**	
<		(Return)

Output status
When you want info on a relay output, the dot will show whether the relay is activated (energized)
for e.g.:
do4 = not activated
do.4 = activated

Message d'anomalie (alarmes)



En cas d'erreur, la LED d'alarme située à l'avant s'allume et le relais d'alarme se déclenche (en fonction de la priorité). Si vous appuyez sur le bouton d'alarme pendant 3 secondes, le rapport d'alarme s'affiche.

Pour plus d'informations, reportez-vous au manuel du contrôleur CO2 sélectionné. (Danfoss AK-CC55 Compact)

Code	Alarm text	Description
E01	Hardware failure	The controller has a hardware failure
E06	Clock lost time	Clock has lost valid time
E20	Pe Evap. pressure A - Sensor error	Sensor signal is out of range. Please check the sensor for correct operation
E24	S2 Gas outlet A - Sensor error	Sensor signal is out of range. Please check the sensor for correct operation
E25	S3 Air ON evap. A - Sensor error	Sensor signal is out of range. Please check the sensor for correct operation
E26	S4 Air OFF evap. A - Sensor error	Sensor signal is out of range. Please check the sensor for correct operation
E27	S5 Evaporator A - Sensor error	Sensor signal is out of range. Please check the sensor for correct operation
A01	High temperature alarm A	The alarm temperature has been above the max alarm limit for a longer time period than the set alarm delay.
A02	Low temperature alarm A	The alarm temperature has been below the min alarm limit for a longer time period than the set alarm delay.
A04	Door open alarm	The door has been open for a too long time
A05	Max defrost hold time exceeded	The controller has been waiting longer time than permitted after a co-ordinated defrost.
A11	Refrigerant not selected	The refrigerant has not been selected hence control can not be initiated
A15	DI alarm 1	Alarm signal from digital input signal
A16	DI alarm 2	Alarm signal from digital input signal
A45	Main switch set OFF	The controller main switch has been set to either Stop or Manual control. Alternatively a digital input set up for "main switch" function, has stopped control
A59	Case in cleaning mode	A case cleaning operation has been started on a case
AA2	CO ₂ leak detected	CO ₂ is leaking from the refrigeration system
AA3	Refrigerant leak detected	Refrigerant is leaking from the refrigeration system
a04	Wrong IO configuration	Inputs and outputs have not been configured correctly

Utilisation du Produit (contrôleur Carel MPXpro)

Mise en marche

Branchez l'appareil.

Le contrôleur de l'armoire est configuré par défaut pour être livré sous tension. Cela signifie que le contrôleur commence à réguler lorsque l'alimentation est branchée et que l'interrupteur principal est en position ON (marche).

Mise sous/hors tension de l'armoire

Pour mettre l'armoire sous/hors tension, utilisez l'interrupteur principal bipolaire, situé sur le côté gauche du boîtier de commande principal, dans le compartiment du compresseur.

Affichage

Disposition/explication :

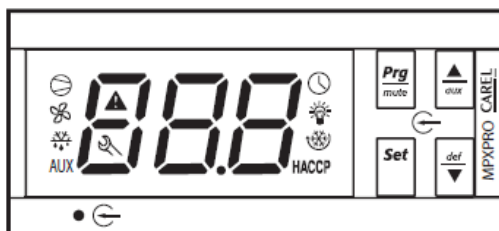

L'affichage ci-dessus comporte trois chiffres.

Plusieurs LED sont installées dans la zone de lecture. Ces LED donnent les indications suivantes.

En général = Lorsqu'une LED clignote, l'activation est retardée ou limitée.

- = Refroidissement activé (lorsque cette LED est allumée, le refroidissement est activé)
- = Ventilateur interne en marche (lorsque cette LED est allumée, le ventilateur interne/évaporateur est activé)
- = Dégivrage activé (lorsque cette LED est allumée, un cycle de dégivrage est en cours)
- = Si la LED clignote, cela indique que la porte est ouverte ou qu'une alarme ou une erreur est en cours.

HACCP = Lorsque cette LED est allumée, une alarme HACCP est en cours. Lorsque cette LED clignote, une alarme HACCP est enregistrée.

Boutons :

Les 4 boutons situés sur le côté droit de l'affichage permettent d'accéder aux différents paramètres et de les régler. Ces boutons peuvent être actionnés seuls ou en combinaison pour commander le contrôleur.

Les paramètres décrits ci-dessous sont les seuls qui doivent être modifiés par l'utilisateur final. L'utilisateur final ne doit pas modifier de paramètres qui ne sont pas expliqués ici. Tous les autres réglages doivent être effectués par un technicien qualifié.

REGLAGES DE L'UTILISATEUR



: Haut



: Bas



:Set



: Prg/mute

Réglage du point de consigne de la température de l'armoire

- Maintenez la touche Set enfoncée pendant le fonctionnement normal jusqu'à ce que l'affichage commence à clignoter. La température de consigne de l'armoire peut être réglée en utilisant les touches Haut et Bas .
- Lorsque le point de consigne a été réglé à la température souhaitée, appuyez brièvement sur le bouton Set pour enregistrer la nouvelle valeur et revenir à un fonctionnement normal.

Procédure de dégivrage manuel

- Maintenez la touche def enfoncée pendant plus de 5 secondes pendant le fonctionnement normal pour effectuer un dégivrage manuel si la température de la sonde de l'évaporateur est suffisamment froide.
- Lorsque le symbole de dégivrage  est allumé, cela indique qu'un dégivrage est en cours.
- Si la touche def est enfoncée pendant plus de 5 secondes lorsqu'un cycle de dégivrage est en cours, le dégivrage est désactivé.

Désactivation des alarmes sonores

- Lorsque le contrôleur est en mode alarme, vous entendrez un signal sonore. L'alarme peut être coupée en appuyant sur Prg/mute .



Réglage des seuils d'alarme de la température

- Maintenez la touche Prg/mute enfoncée pendant plus de 5 secondes pendant le fonctionnement normal pour ouvrir la liste des paramètres. L'écran affiche **/c1**
- Appuyez sur Prg/mute . La première catégorie de paramètres, « Pro », est affichée.
- Appuyez sur la touche Haut jusqu'à atteindre la catégorie « ALn », indiquée par l'icône  allumée à l'écran.
- Appuyez sur Set le paramètre AA s'affiche.
- Appuyez sur la touche Haut jusqu'à atteindre A1.
- Appuyez sur Set pour définir si les paramètres AL (**A**larm **L**ow : seuil d'alarme basse température) et AH (**A**larm **H**igh : seuil d'alarme haute température) doivent être définis sur (0 = par rapport aux valeurs de consigne de température de l'armoire) ou (1 = valeur absolue) par défaut = 1.
- Appuyez sur Set pour enregistrer le paramètre sélectionné et revenir à A1.
- Appuyez sur la touche Haut jusqu'à atteindre AL (**A**larm **L**ow : seuil d'alarme basse température).
- Appuyez sur Set pour régler AL en utilisant les touches Haut et Bas (réglable entre -50 et +50) Réglage par défaut = -50 °C.
- Appuyez sur Set pour enregistrer le paramètre choisi et revenir à AL.
- Appuyez sur la touche Haut jusqu'à atteindre AH (**A**larm **H**igh : seuil d'alarme haute température).
- Appuyez sur Set pour permettre le réglage de AH en utilisant les touches Haut et Bas (réglable entre -50 et +50) Réglage par défaut = +50 °C.
- Appuyez sur Set pour enregistrer le paramètre choisi et revenir à AH.
- Appuyez sur la touche Haut jusqu'à atteindre Ad (**A**larm **D**elay : temporisation de l'alarme pour AL et AH).
- Appuyez sur Set pour permettre le réglage de Ad en utilisant les touches Haut et Bas (réglable entre 0 et 240 minutes) Réglage par défaut = 120 minutes.
- Appuyez sur Set pour enregistrer le réglage défini et revenir à Ad.
- Appuyez sur Prg/mute pendant plus de 5 secondes pour enregistrer les modifications et revenir au menu principal.

Afin de créer des seuils d'alarme de température et une temporisation de l'alarme adaptés à un réfrigérateur ou un congélateur, les exemples de réglage d'alarme ci-



dessous peuvent être suggérés :

	Point de consigne	A1	AL	AH	Ad
Réfrigérateur	+5 °C	1	+1 °C	+8 °C	120 min
Congélateur	-18 °C	1	-50 °C	-15 °C	120 min

Affichage du journal des alarmes

- Appuyez sur Prg/mute et sur Set pendant 5 secondes.
- Entrez le mot de passe : 44.
- Appuyez sur Set pour accéder à un sous-menu où les touches Haut et Bas sont utilisées pour faire défiler les différentes alarmes, HS0 à HS9.

- Sélectionnez une alarme et appuyez sur Set pour afficher le code, l'heure, les minutes et la durée.
- A partir de n'importe quel sous-paramètre, une pression sur Prg/mute fera revenir le contrôleur au paramètre parent « HSx ».

- Appuyez sur Prg/mute pendant 5 secondes pour revenir à l'affichage

standard. Exemple :

« HI » -> « h17 » -> « m23 » -> « 65 »

indique que l'alarme « HI » (alarme de température élevée) s'est déclenchée à 17:23 et a duré 65 minutes.

ALARMES HACCP

Deux types d'événements HACCP sont gérés :

- alarmes de type HA, température élevée pendant le fonctionnement ;
- alarmes de type HF, température élevée après une panne de courant (coupure de courant).

Lorsqu'une alarme est enregistrée, la LED HACCP clignote, l'affichage donne le code d'alarme, l'alarme est enregistrée, et le relais d'alarme et l'avertisseur sonore sont activés.

Affichage des alarmes HA et HF

- Appuyez simultanément sur les touches Prg/mute et Bas .
- Faites défiler la liste des alarmes en appuyant sur les touches Haut et Bas .
- Appuyez sur Set pour sélectionner l'alarme requise.
- Utilisez la touche Haut ou Bas pour afficher la description de l'alarme : année, mois, jour, heures, minutes et durée en minutes de l'alarme sélectionnée.
- Appuyez à nouveau sur Prg/mute pour revenir à la liste précédente.



De plus, le menu d'alarme HACCP permet les opérations suivantes :

Suppression d'une alarme HACCP

- Appuyez sur les touches Set et Bas pendant 5 secondes pour afficher la liste des alarmes.

HACCP clignote alors, l'affichage indique le message rES et la surveillance des alarmes HACCP est réinitialisée.

Suppression de toute la mémoire des alarmes HACCP

- Appuyez sur les touches Set , Haut et Bas pendant 5 secondes. Cette procédure affiche le message rES, supprime toute la mémoire des alarmes et réinitialise la surveillance des alarmes HACCP.



































Afin de pouvoir utiliser les alarmes HACCP, il est nécessaire que l'horloge en temps réel ait été réglée par l'installateur avant la remise de l'armoire à l'utilisateur final. Ces réglages sont protégés par un code d'accès et ne peuvent donc pas être effectués par l'utilisateur final.

Eclairage de l'armoire

Sur toutes les armoires, l'éclairage est placé à l'extérieur, au-dessus de la porte. Cet éclairage est commandé par le contrôleur principal, ce qui signifie que son fonctionnement ne peut pas être modifié.

Lorsque la porte de l'armoire est ouverte, l'éclairage situé au-dessus de la porte est allumé. Lorsque vous fermez la porte, l'éclairage situé au-dessus de la porte s'éteint.

Erreurs et alarmes

Display code	Cause of the alarm	Icon flash on display	Alarm relay	Buzzer	Reset	Compressor	Defrost	Evaporator fans	Continuous cycle	Signalled on tLAN	Network solenoid valve
rE	Control probe fault		ON	ON	automatic	duty setting(c4)	unchanged	unchanged	unchanged	√	-
E1	Probe S1 fault		OFF	OFF	automatic	duty setting(c4)	unchanged	unchanged	unchanged	√	-
E2	Probe S2 fault		OFF	OFF	automatic	unchanged	unchanged	unchanged	unchanged	√	-
E3	Probe S3 fault		OFF	OFF	automatic	unchanged	unchanged	unchanged	unchanged	√	-
E4	Probe S4 fault		OFF	OFF	automatic	unchanged	unchanged	unchanged	unchanged	√	-
E5	Probe S5 fault		OFF	OFF	automatic	unchanged	unchanged	unchanged	unchanged	√	-
E6	Probe S6 fault		OFF	OFF	automatic	unchanged	unchanged	unchanged	unchanged	√	-
E7	Probe S7 fault		OFF	OFF	automatic	unchanged	unchanged	unchanged	unchanged	√	-
E8	Serial probe S8 not updated		OFF	OFF	automatic	duty setting(c4)	unchanged	unchanged	unchanged	√	-
E9	Serial probe S9 not updated		OFF	OFF	automatic	duty setting(c4)	unchanged	unchanged	unchanged	√	-
E10	Serial probe S10 not updated		OFF	OFF	automatic	duty setting(c4)	unchanged	unchanged	unchanged	√	-
E11	Serial probe S11 not updated		OFF	OFF	automatic	duty setting(c4)	unchanged	unchanged	unchanged	√	-
LO	Low temperature alarm		ON	ON	automatic	unchanged	unchanged	unchanged	unchanged	√	-
HI	High temperature alarm		ON	ON	automatic	unchanged	unchanged	unchanged	unchanged	√	-
LO2	Low temperature alarm		ON	ON	automatic	unchanged	unchanged	unchanged	unchanged	√	-
HI2	High temperature alarm		ON	ON	automatic	unchanged	unchanged	unchanged	unchanged	√	-
IA	Immediate alarm from external contact		ON	ON	automatic	duty setting(A6)	unchanged	unchanged	unchanged	√	-
dA	Delayed alarm from external contact		ON	ON	automatic	duty setting(A6) if A7≠0	unchanged	unchanged	unchanged	√	-
dor	Door open for too long alarm		ON	ON	automatic	unchanged	unchanged	unchanged	unchanged	√	-
Etc	Real time clock fault		OFF	OFF	automatic	unchanged	unchanged	unchanged	unchanged	√	-
LSH	Low superheat alarm		OFF	OFF	automatic	OFF	unchanged	unchanged	unchanged	√	√
LSA	Low suction temperature alarm		OFF	OFF	automatic / manual	OFF (paragraph 6.10)	unchanged	unchanged	unchanged	√	√
MOP	Maximum evaporation pressure alarm		OFF	OFF	automatic	OFF	unchanged	unchanged	unchanged	√	√
LOP	Low evaporation temperature alarm		OFF	OFF	automatic	unchanged	unchanged	unchanged	unchanged	√	√
bLo	Valve blocked alarm		OFF	OFF	manual / disabled with P14=0	unchanged	unchanged	unchanged	unchanged	√	-
Edc	Communication error with stepper driver		ON	ON	automatic	unchanged	unchanged	unchanged	unchanged	√	-
EFS	Stepper motor broken/not connected		ON	ON	automatic	unchanged	unchanged	unchanged	unchanged	√	-
EE	Flash unit parameter error		OFF	OFF	automatic	OFF	not performed	OFF	not performed	√	-
EF	EEPROM operating parameter error		OFF	OFF	automatic	OFF	not performed	OFF	not performed	√	-
HA	Type HA HACCP alarm	HACCP	OFF	OFF	manual	unchanged	unchanged	unchanged	unchanged	√	-
HF	Type HF HACCP alarm	HACCP	OFF	OFF	manual	unchanged	unchanged	unchanged	unchanged	√	-
MA	Communication error with Master (only on Slave)		ON	ON	automatic	unchanged	unchanged	unchanged	unchanged	-	-
u1...u5	Communication error with Slave (only on Master)		ON	ON	automatic	unchanged	unchanged	unchanged	unchanged	-	-
n1...n5	Alarm on unit 1 to 5 in the network		ON	ON	automatic	unchanged	unchanged	unchanged	unchanged	-	-
up1...up5	Upload procedure with errors on unit 1 to 5		OFF	OFF	-	unchanged	unchanged	unchanged	unchanged	-	-
GPE	Error in custom gas parameters		ON	ON	automatic	OFF	not performed	OFF	not performed	√	-



Pour plus d'informations, reportez-vous au manuel du contrôleur CO2 sélectionné. (Carel MPX PRO)



Utilisation du Produit NC (pas de contrôleur – modèle)



Veillez consulter le manuel fourni avec le contrôleur installé.

Dépannage

Bruit :

- En cas de bruit anormal, faites appel au service d'assistance.
- Les bruits de fonctionnement du ventilateur intérieur sont normaux.
- Si des pièces en tôle, des panneaux avant ou des panneaux situés à l'avant du compartiment font du bruit, ceux-ci peuvent être ouverts. Fermez les panneaux.

Gel dans le compartiment :

- Humidité ambiante trop élevée.
- La porte est ouverte trop souvent.
- La porte est laissée ouverte trop longtemps.
- Joint de porte endommagé. Inspectez-le soigneusement pour voir le niveau d'endommagement.

Mauvaises performances de refroidissement :

- Température ambiante trop élevée.
- La porte est ouverte trop souvent et/ou trop longtemps.
- La porte est restée ouverte.
- Joint de porte endommagé.
- Réglage de température trop élevé.
- L'appareil est surchargé d'aliments ou l'entrée/la sortie d'air est bloquée.
- Aliments tièdes ou chauds à l'intérieur de l'armoire.
- Dégivrage en cours. Pendant le cycle de dégivrage, il se peut que la température interne de l'armoire augmente, mais cela n'affectera en rien les aliments placés à l'intérieur. La LED de dégivrage est allumée.

Certains aliments sont congelés :

- L'appareil est surchargé d'aliments ou l'entrée/la sortie d'air est bloquée.
- Température de consigne trop basse.
- Le ventilateur de l'évaporateur est peut-être défectueux.

Condensation autour de la porte :

- Humidité ambiante trop élevée.
- La porte est mal fermée.
- Joint de porte endommagé.
- Le paramètre relatif au dispositif de chauffage de l'encadrement de la porte n'a pas été réglé correctement.

Consommation d'énergie trop élevée :

- Température ambiante trop élevée.
- La porte est ouverte trop souvent et/ou trop longtemps.
- La porte est restée ouverte.
- Joint de porte endommagé.
- Température de consigne trop basse.
- L'appareil est surchargé d'aliments ou l'entrée/la sortie d'air est obstruée.
- Des aliments tièdes ou chauds sont introduits dans l'armoire.
- L'armoire est exposée à la lumière directe du soleil ou installée à proximité de surfaces émettrices de chaleur.
- Les paramètres par défaut ont été modifiés.

Eau de Dégivrage

Pendant le dégivrage, l'armoire produit de l'eau, qui est amenée dans le système de réévaporation par aspiration à travers une pièce en plastique en haut de l'armoire (pour les armoires Premier).

L'eau est à nouveau évaporée à l'aide d'un élément de chauffage électrique et un moteur de ventilateur. Dans de rares cas, le modèle d'utilisation de l'armoire crée plus d'eau que l'appareil ne peut en réévaporer, ce qui peut entraîner un débordement d'eau. Dans ce cas, l'élément chauffant électrique peut être modifié pour fonctionner à 100 % ou débranché et la conduite d'eau située à l'arrière est alors raccordée à l'égout. Ces modifications doivent être effectuées par un technicien d'entretien qualifié.

Mécanisme de Fermeture de Porte

La porte est équipée d'un système de fermeture automatique. Si la porte est ouverte à moins de 90°, elle se ferme toute seule. Si la porte est ouverte à plus de 90°, elle reste ouverte.

La porte peut être ouverte en utilisant la pédale. Cela laisse les deux mains libres lors de l'installation des aliments dans l'armoire.

Panne de Courant

En cas de panne de courant, le contrôleur mémorise le réglage de la température et redémarre l'armoire à la remise sous tension.

Nettoyage



Si le nettoyage est insuffisant, les performances de l'armoire peuvent ne pas être optimales, et un dysfonctionnement peut même survenir.



Avant le nettoyage, l'armoire doit toujours être débranchée.

Ne rincez pas l'armoire avec de l'eau, n'utilisez pas de jet d'eau ou de tuyau de vapeur car cela pourrait entraîner des courts-circuits dans le système électrique.



Les produits de nettoyage contenant du chlore ou des composés chlorés, ainsi que d'autres produits corrosifs, **ne doivent pas être utilisés** car ils risquent de provoquer une corrosion des panneaux inoxydables de l'armoire et de l'évaporateur.



L'armoire doit être protégée de la poussière et de la saleté. Il est préférable de le faire avec un aspirateur et une brosse.



Pour l'entretien externe, utilisez un produit à polir pour acier inoxydable.



L'intérieur de l'armoire doit être nettoyé avec une solution savonneuse douce à intervalles appropriés et contrôlé soigneusement avant de le remettre en service.

Joint de Porte

Ce chapitre traite de l'importance de la bonne condition des joints de porte.

Les joints sont une pièce importante d'un réfrigérateur/congélateur. Les joints qui ne fonctionnent pas correctement réduisent l'étanchéité de l'armoire. Une réduction de l'étanchéité peut entraîner une augmentation de l'humidité, un givrage interne, un évaporateur givré (entraînant une réduction de la capacité de réfrigération) et, dans le pire des cas, une réduction du cycle de vie de l'armoire.



Par conséquent, il est important de connaître l'état du joint. Une inspection régulière est recommandée.

Le joint doit être nettoyé régulièrement à l'aide d'une solution savonneuse douce. Si un joint doit être remplacé, contactez votre fournisseur.

Remisage à Long Terme

Si l'armoire est mise hors service et doit être préparée pour un remisage à long terme, nettoyez soigneusement le compartiment intérieur, la porte et le joint de porte à l'aide d'un chiffon imbibé d'eau chaude savonneuse. Des restes de nourriture pourraient créer de la moisissure.

Réparations







Si la réfrigération échoue, vérifiez d'abord si l'unité a été débranchée ou mise hors tension involontairement au niveau de la prise, ou si un fusible a grillé.

S'il n'est pas possible de trouver la cause de la panne de réfrigération, veuillez contacter l'installateur de l'unité.

Si vous contactez HOSHIZAKI ou l'installateur, veuillez nous indiquer le nom et le numéro de série indiqués à l'intérieur de l'armoire. Ces informations sont marquées sur la plaque signalétique.

Données Techniques

Emplacement de l'étiquette :

PRODUCT DESCRIPTION LABEL		
1 Product Number		PRODUCT NUMBER: 1
2 Product Description		
3 Model		PRODUCT DESCRIPTION: 2
4 Refrigerant (GWP)		MODEL: 3
5 CO2 Equivalent		REFRIGERANT: 4
6 IP Protection		CO2 EQUIVALENT: 5
7 Climate Class		IP PROTECTION: 6
8 Production Date		CLIMATE CLASS: 7
9 Total power / Current / Lamp power		PRODUCTION DATE: 8
10 Voltage - Frequency		TOTAL POWER / CURRENT / LAMP POWER: 9
11 Heating Element		VOLTAGE - FREQUENCY: 10
12 System Pressure		HEATING ELEMENT: 11
13 Blowing Agent		SYSTEM PRESSURE: 12
14 Serial Number		BLOWING AGENT: 13
		S/N: 14 
		HOSHIZAKI EUROPE B.V. Burgemeester Stramanweg 101 1101 AA Amsterdam, The Netherlands
		  

Trade mark			HOSHIZAKI			
Model name			PREMIER U 70	PREMIER U 140	PREMIER U 80	PREMIER U 60
Usage prévu			Storage	Storage	Storage	Storage
Température de réfrigération			X	X	X	X
Température de congélation			X	X	X	X
Armoire polyvalente						
Armoire verticale			X	X	X	X
Comptoir réfrigéré						
Parameter	Symbol	Unit				
Volume brut	VnT	L	700	1400	700	480
Classe climatique			CC5	CC5	CC5	CC5
Tension d'alimentation/Fréquence	V / Hz		230 - 50	230 - 50	230 - 50	230 - 50
Réfrigérant (armoire CO2)			CO2	CO2	CO2	CO2
Réfrigérant (armoire RU-1)			HFC / HFO Refrigerant*	HFC / HFO Refrigerant*	HFC / HFO Refrigerant*	HFC / HFO Refrigerant*
Contact	HOSHIZAKI EUROPE B.V. Address: Burgemeester Stramanweg 101 1101 AA Amsterdam, The Netherlands Tel: +31 (0)20 691 84 99 - http://hoshizaki.europe.com/					

* Réfrigérants compatibles avec l'embouchure (R449A, R448A, R45A, etc. Veuillez consulter la fiche signalétique de l'embouchure utilisée)

HOSHIZAKI

Premier Remote Cabinets



Trade mark			HOSHIZAKI		
Model name			BAKER U 950	BAKER GA 950	PREMIER SF 950
Usage prévu			Storage	Cooling /Freezing / Storage / Proving	Cooling / Shock Freezing
Température de réfrigération			X	X	X
Température de congélation			X	X	X
Armoire polyvalente				X	X
Armoire verticale			X	X	X
Comptoir réfrigéré					
Parameter	Symbol	Unit			
Volume brut	VnT	L	1000	950	950
Classe climatique			CC5	CC5	CC5
Tension d'alimentation/Fréquence	V / Hz		230 - 50	230 – 50	230 – 50
Réfrigérant (armoire RU-1)			HFC / HFO Refrigerant*	HFC / HFO Refrigerant*	HFC / HFO Refrigerant*
Contact	HOSHIZAKI EUROPE B.V. Address: Burgemeester Stramanweg 101 1101 AA Amsterdam, The Netherlands Tel: +31 (0)20 691 84 99 - http://hoshizaki.europe.com/				

* Réfrigérants compatibles avec l'embouchure (R449A, R448A, R45A, etc. Veuillez consulter la fiche signalétique de l'embouchure utilisée)

Dimensions

PREMIER U 70

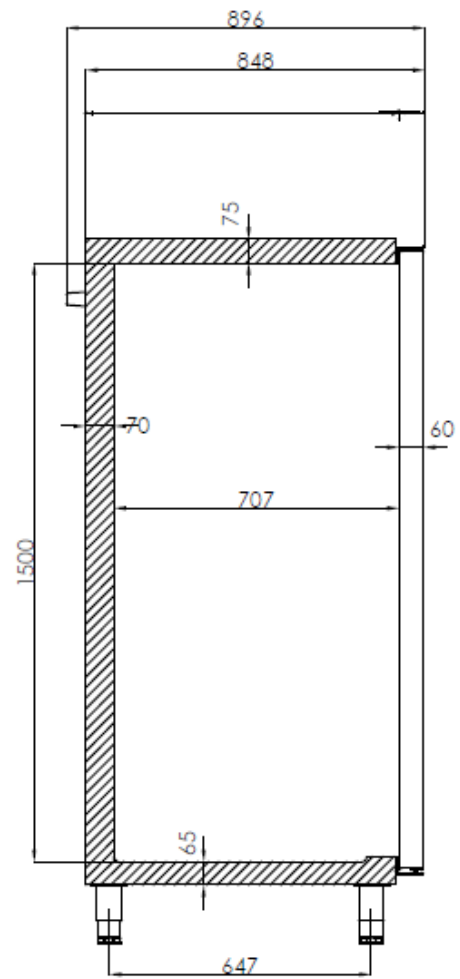
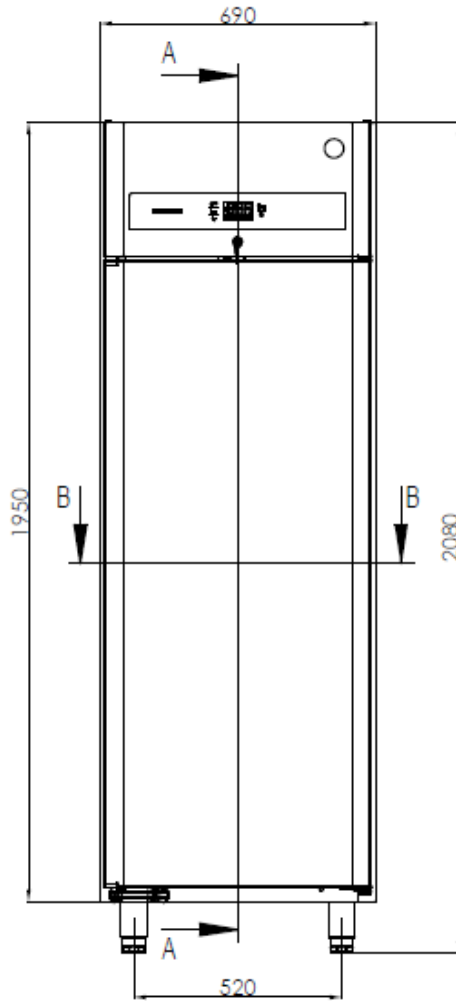

A-A

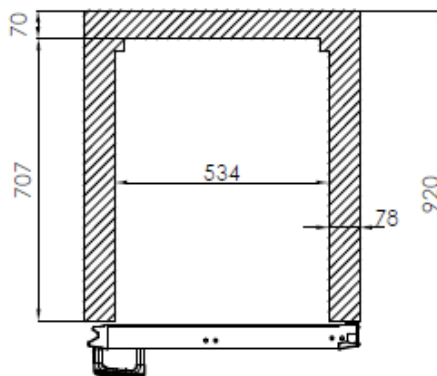

B-B

HOSHIZAKI

Premier Remote Cabinets



PREMIER U 60

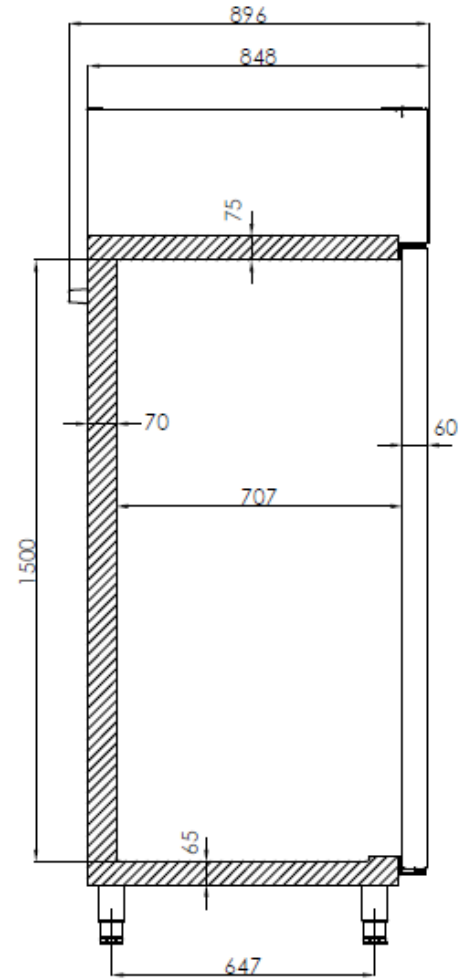
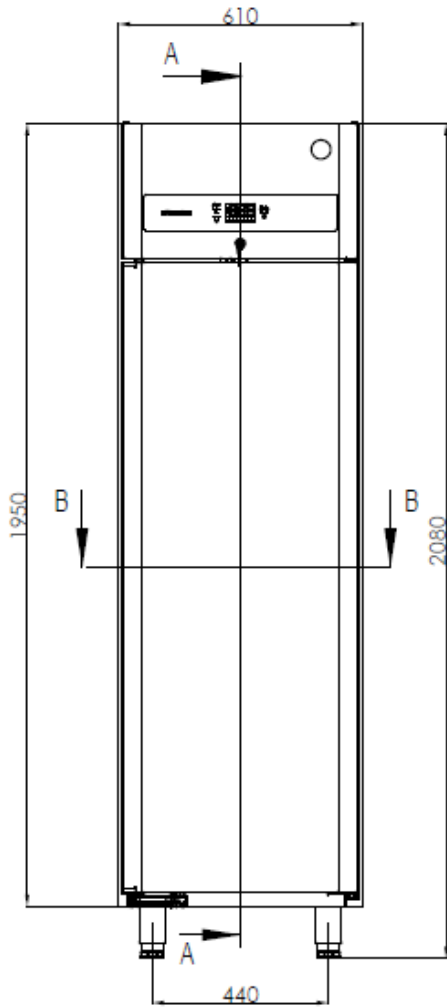

A-A

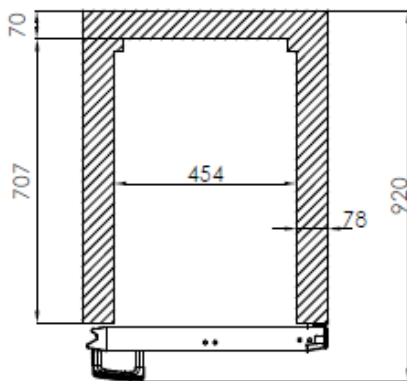

B-B

HOSHIZAKI

Premier Remote Cabinets



PREMIER U 80

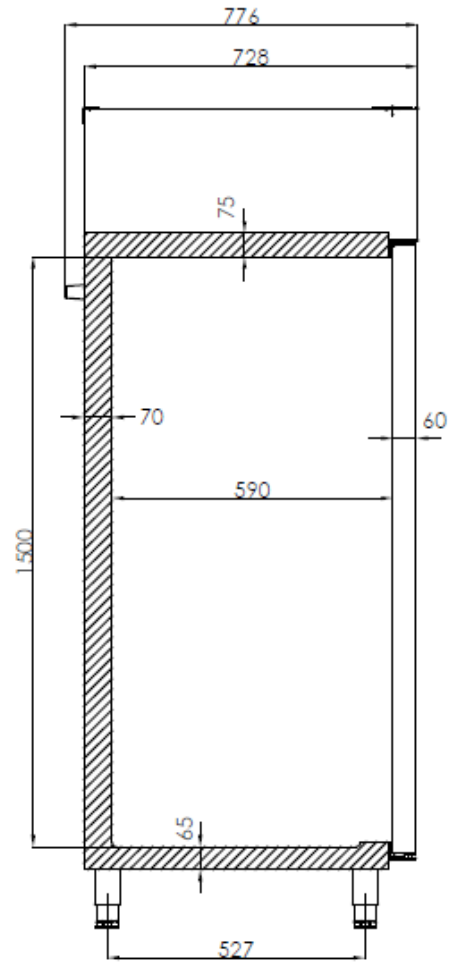
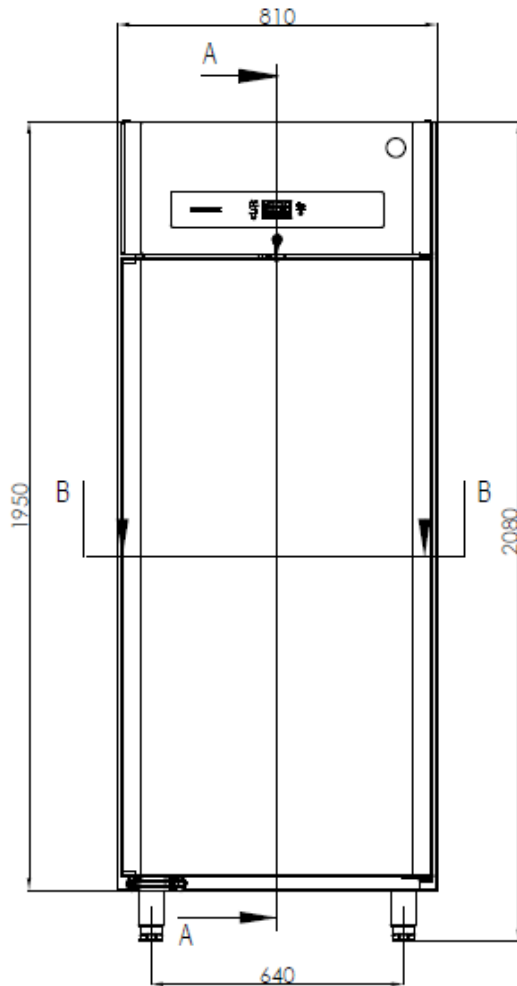

A-A

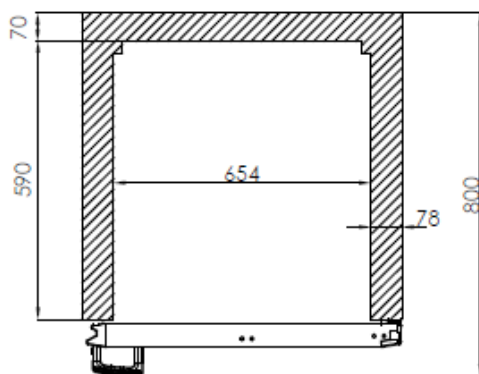

B-B

HOSHIZAKI

Premier Remote Cabinets



PREMIER U 140

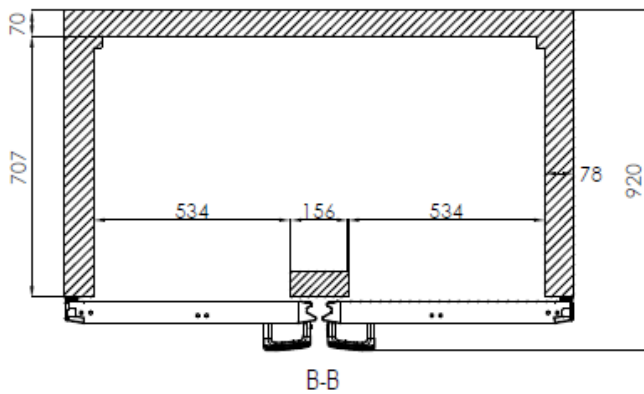
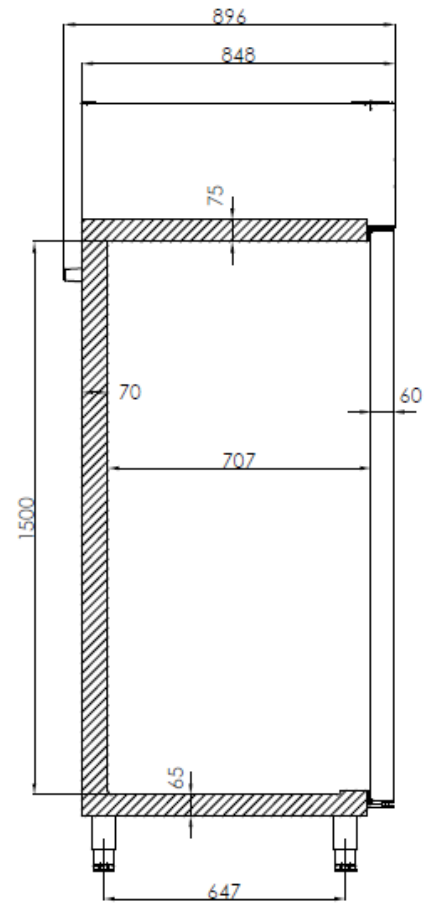
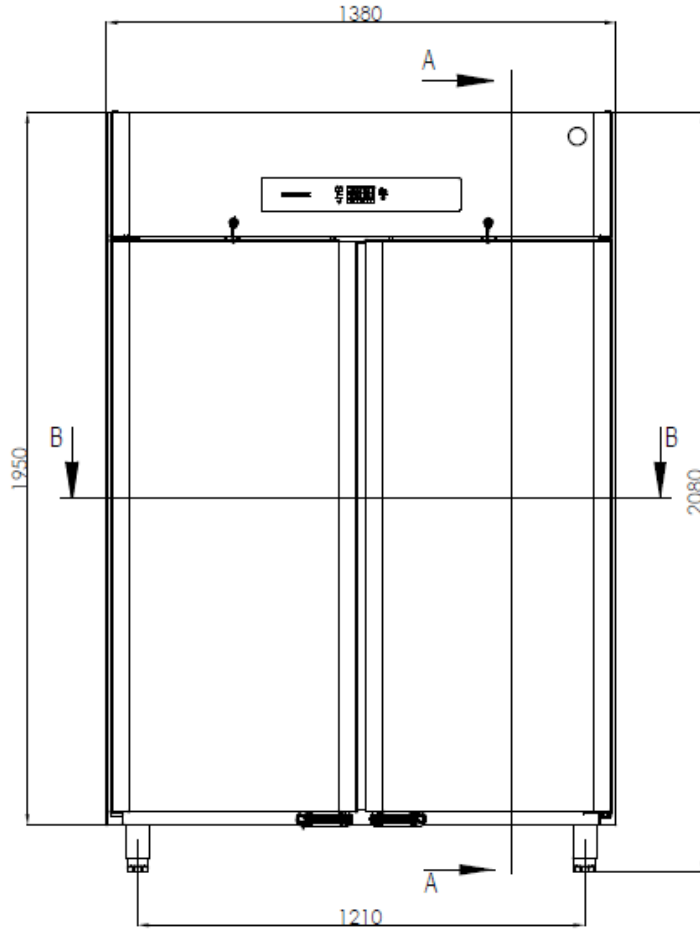

HOSHIZAKI

Premier Remote Cabinets



BAKER U 950

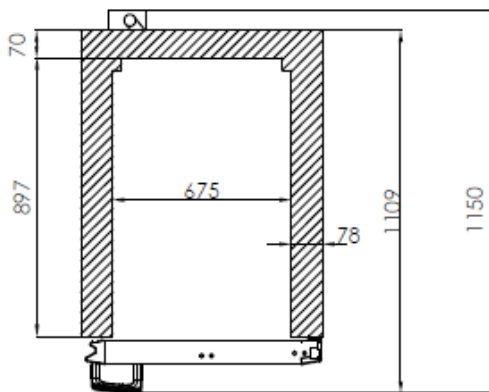
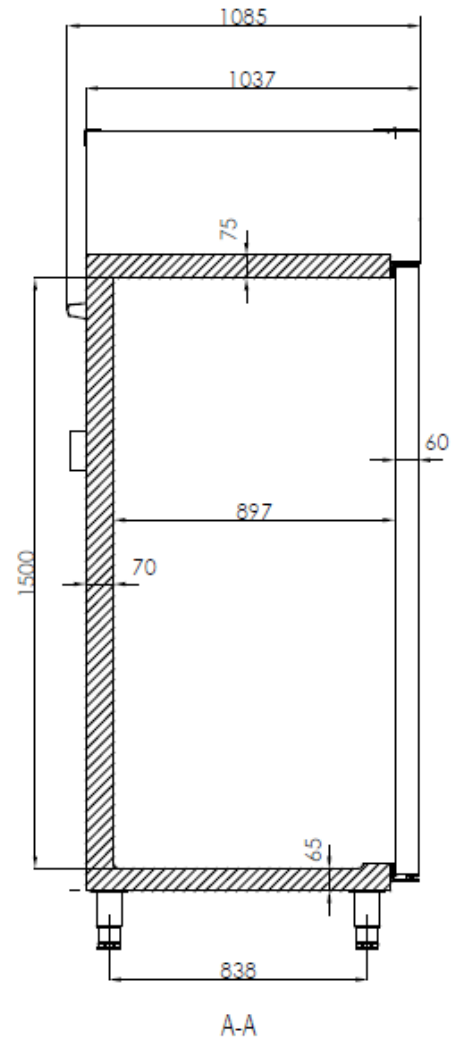
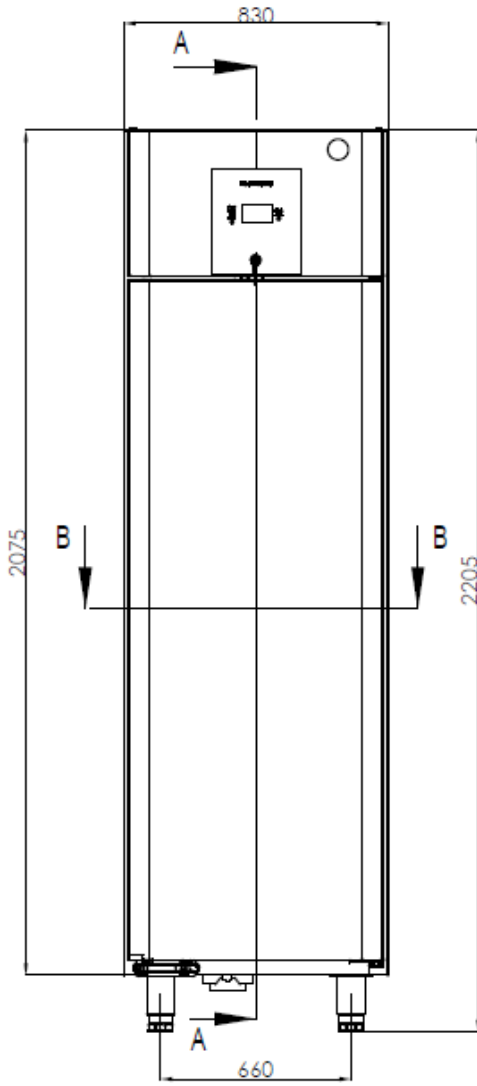

HOSHIZAKI

Premier Remote Cabinets



BAKER GA 950 (RU1)

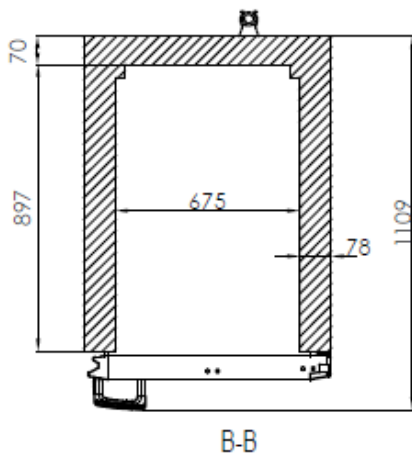
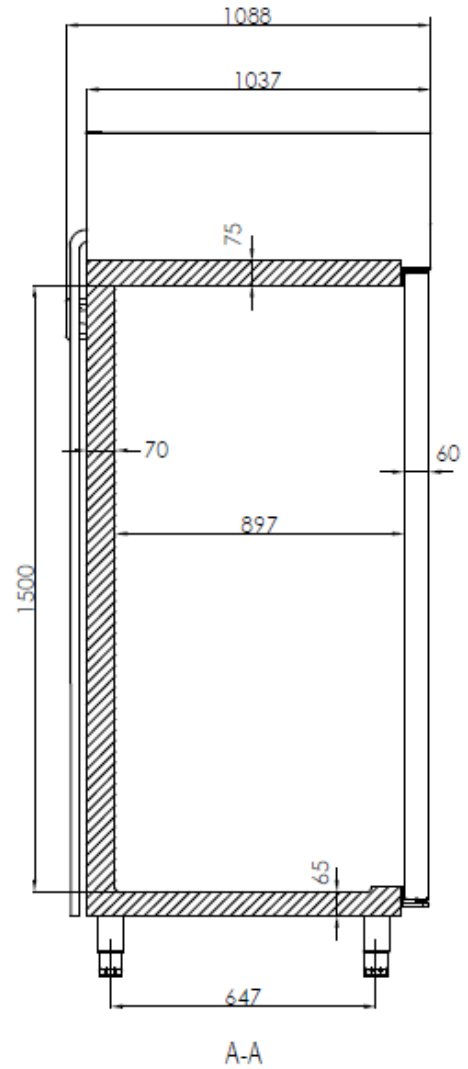
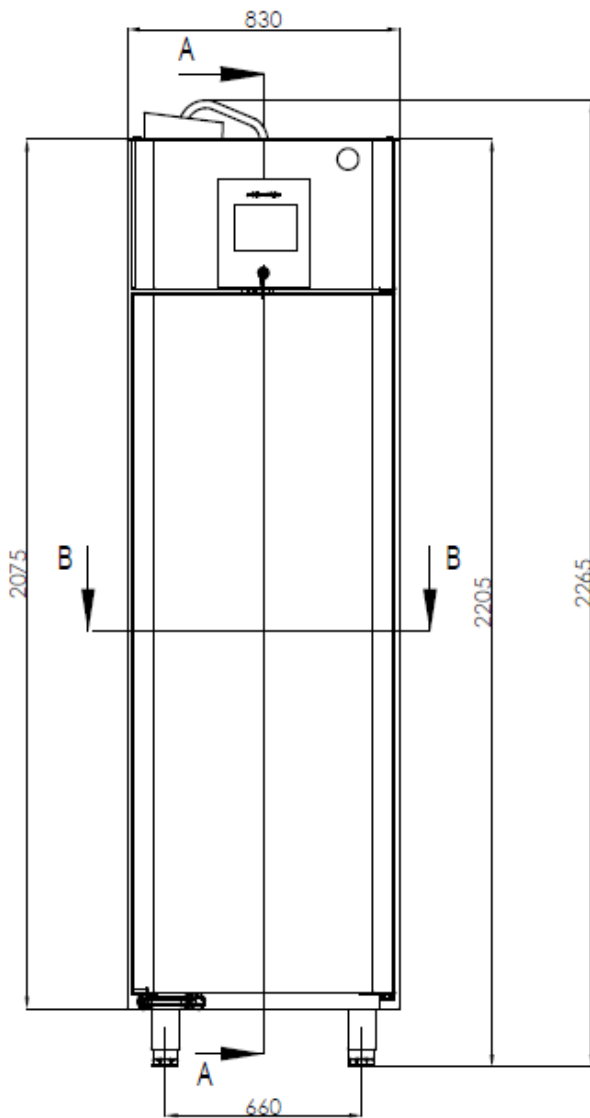

HOSHIZAKI

Premier Remote Cabinets



BAKER SF 950 (RU1)

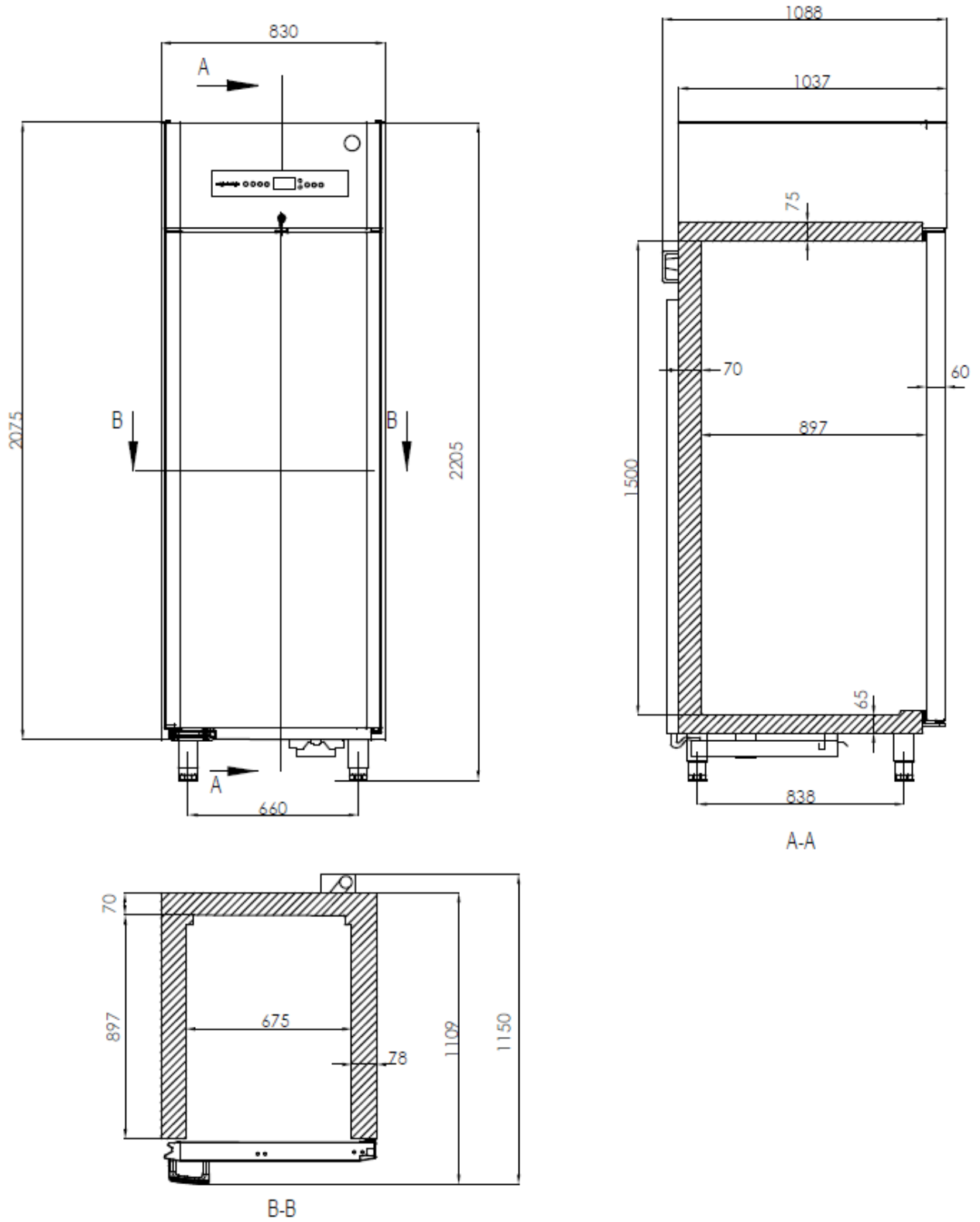

Mise au Rebut

Le texte ci-dessous ne concerne que le Royaume-Uni.

La mise au rebut d'une ancienne armoire n'est possible qu'à la livraison d'une nouvelle armoire. Les armoires doivent être complètement dégivrées et vidées avant la collecte.

Hoshizaki reconnaît que nos produits destinés au marché de la restauration sont considérés comme des DEEE lorsqu'ils deviennent obsolètes. Pour garantir que les responsabilités de Hoshizaki sont gérées correctement et dans le respect de l'environnement, nous avons signé le plus grand programme de conformité Business to Business au Royaume-Uni : B2B Compliance <http://www.b2bcompliance.org.uk>

Le programme B2B Compliance s'occupera en notre nom de tous les domaines de notre responsabilité lors de la collecte et de la mise au rebut des équipements qui relèvent de la réglementation britannique en matière de DEEE. Le programme B2B Compliance peut être contacté au numéro de téléphone 01691 676124.





Schémas Electriques

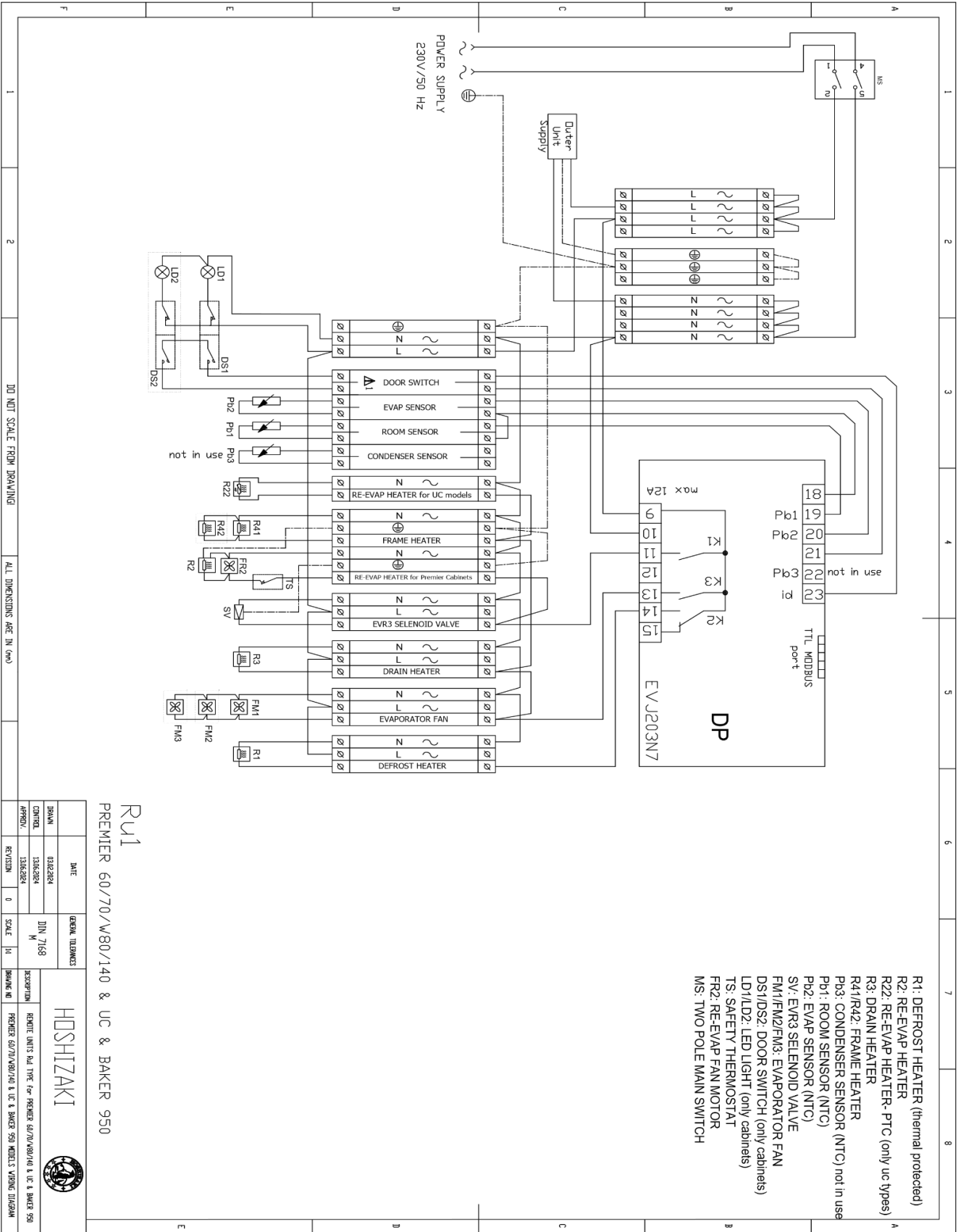

DO NOT SCALE FROM DRAWING

ALL DIMENSIONS ARE IN (mm)

DATE	GENERAL TOLERANCES	REVISION	SCALE	IN	BY
03/28/2014	DIN 7168	0	1:1		
13/06/2014	M				
13/06/2014					
03/28/2014					

Ru1
PREMIER 60/70/W80/140 & UC & BAKER 950

HOSHIZAKI

REVISION: 03/28/2014
BY: HOSHIZAKI
DESCRIPTION: REMOTE UNITS for PREMIER 60/70/W80/140 & UC & BAKER 950
DRAWN BY: PREMIER 60/70/W80/140 & UC & BAKER 950 MODELS USING EUROPEAN

HOSHIZAKI

Premier Remote Cabinets

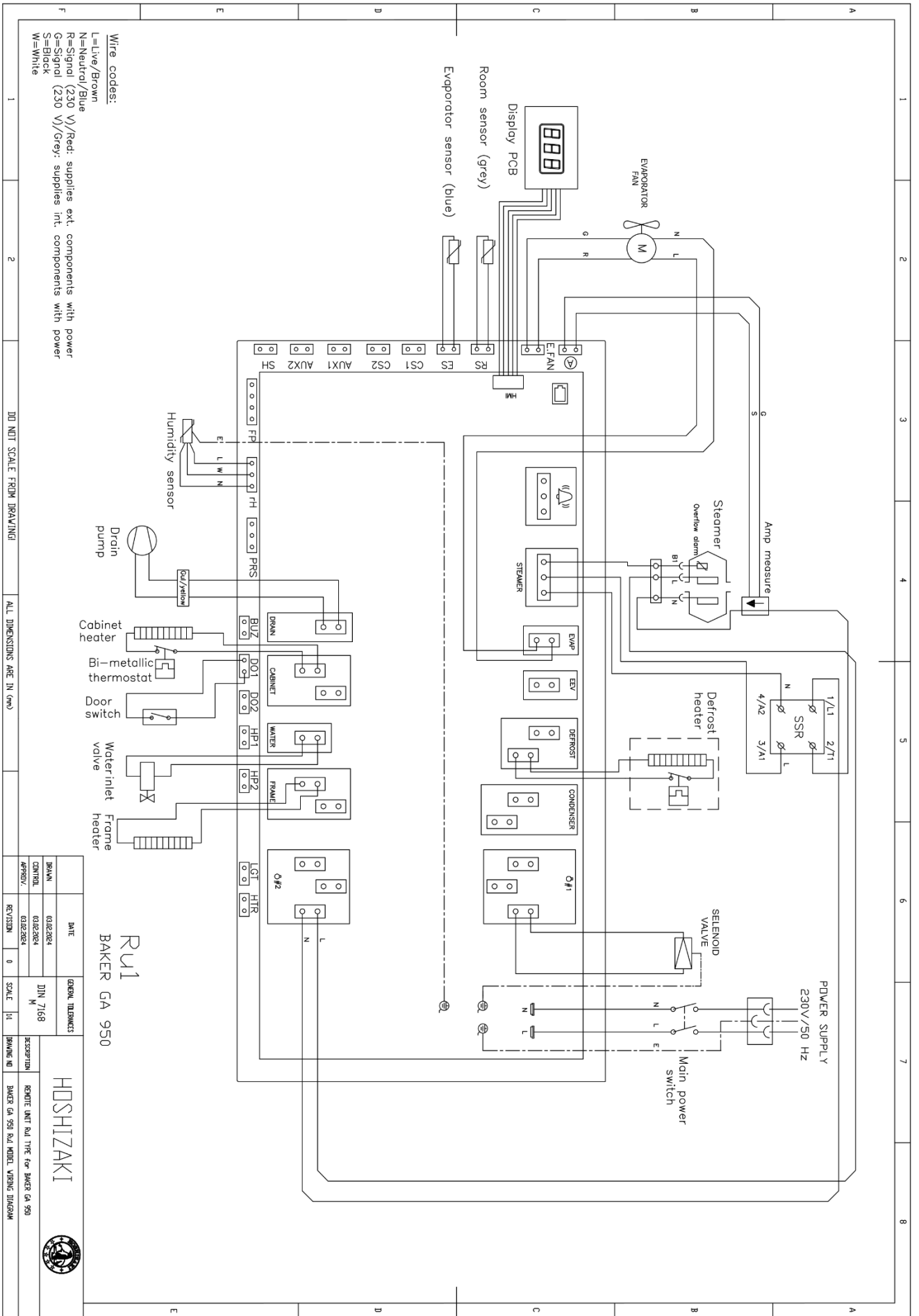

HOSHIZAKI

Premier Remote Cabinets

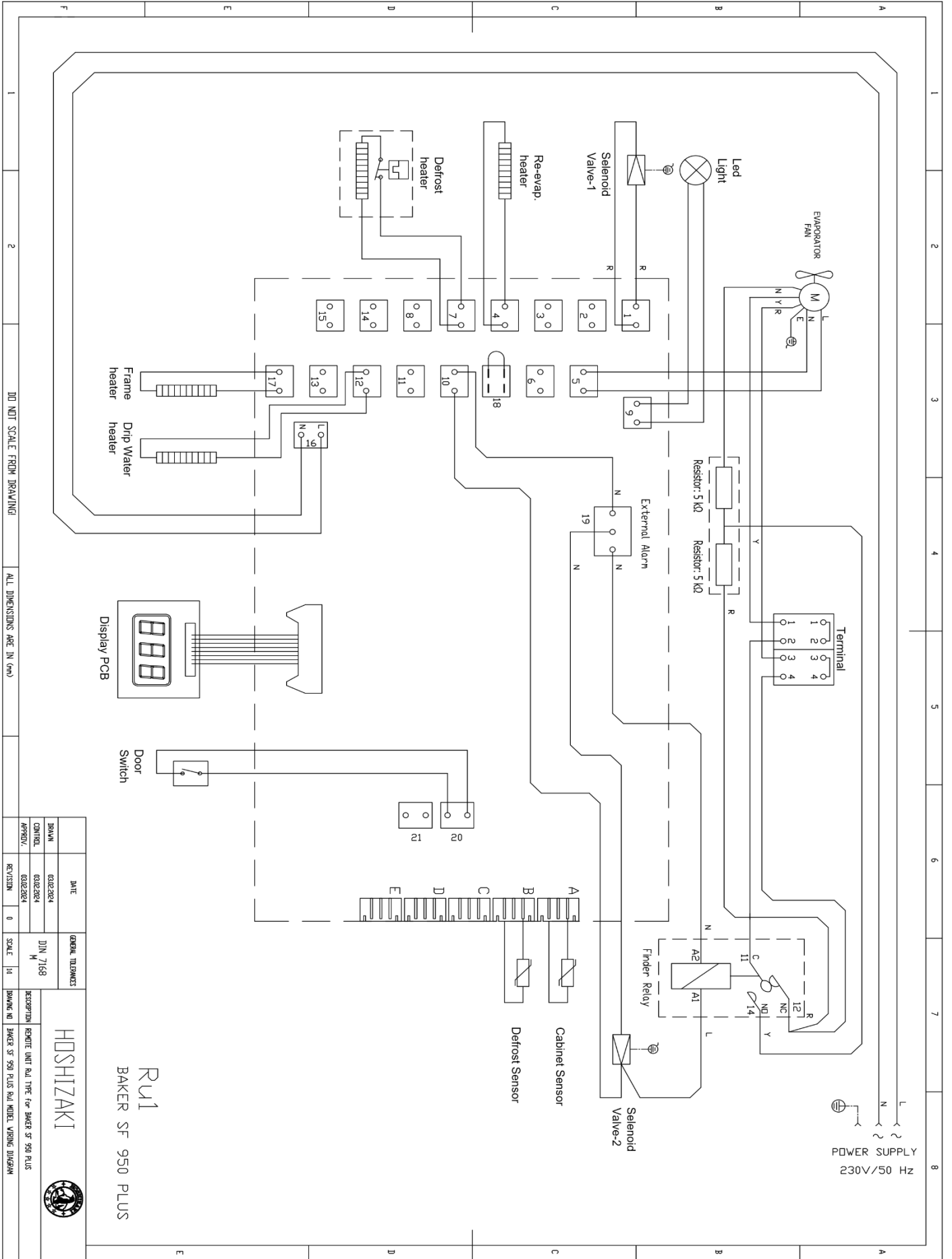

RU1
BAKER SF 950 PLUS

DO NOT SCALE FROM DRAWING
ALL DIMENSIONS ARE IN (mm)

GENERAL DIMENSIONS		DATE	
DRAWN	03/23/24	DATE	03/23/24
CONTROL	03/23/24	REVISION	0
APPROV.	03/23/24	SCALE	1:1

HOSHIZAKI



RECEPTION: BAKER SF 950 PLUS
DRAWING NO: BAKER SF 950 PLUS RAJ MODEL, VARIOUS DIMENSIONS

HOSHIZAKI

Premier Remote Cabinets

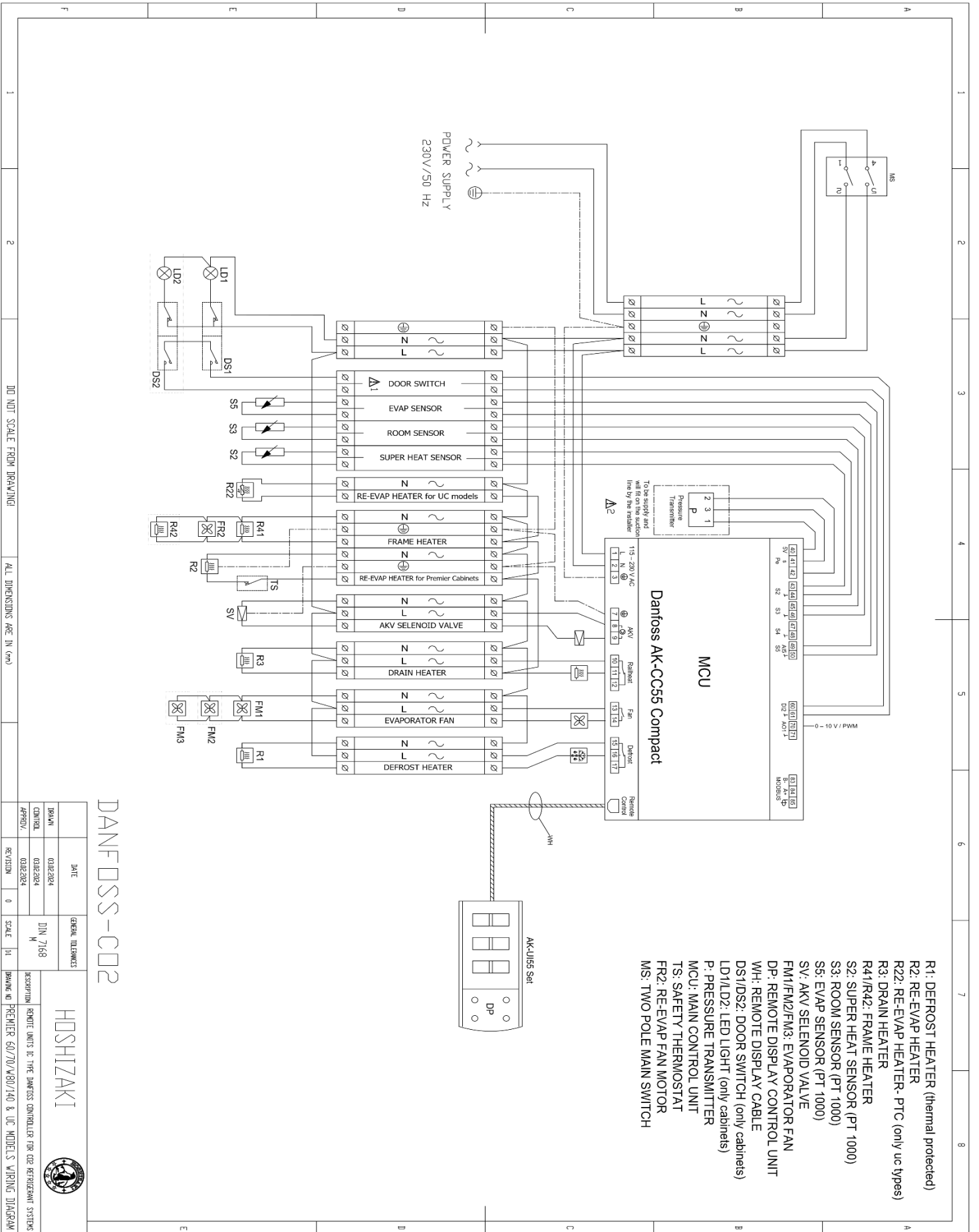

- R1: DEFROST HEATER (thermal protected)
- R2: RE-EVAP HEATER
- R22: RE-EVAP HEATER- PTC (only uc types)
- R3: DRAIN HEATER
- R41/R42: FRAME HEATER
- S2: SUPER HEAT SENSOR (PT 1000)
- S3: ROOM SENSOR (PT 1000)
- S5: EVAP SENSOR (PT 1000)
- SV: AKV SELENOID VALVE
- FM1/FM2/FM3: EVAPORATOR FAN
- DP: REMOTE DISPLAY CONTROL UNIT
- DS1/DS2: DOOR SWITCH (only cabinets)
- W/H: REMOTE DISPLAY CABLE
- P: PRESSURE TRANSMITTER
- MCU: MAIN CONTROL UNIT
- TS: SAFETY THERMOSTAT
- FR2: RE-EVAP FAN MOTOR
- MS: TWO POLE MAIN SWITCH

DANFOSS-CC2

DATE	03.02.2024	GENERAL TOLERANCES	DIN 7168
DRAWN	03.02.2024		
CONTROL	03.02.2024		
APPROV.	03.02.2024		
REVISION	0	SCALE	1:1

DESCRIPTION: REMOTE UNITS TO THE DANFOSS CONTROLLER FOR CO2 REFRIGERANT SYSTEMS
 DRAWING NO: PREMIER 60/70/80/140 & UC MODELS WIRING DIAGRAM



HOSHIZAKI

Premier Remote Cabinets

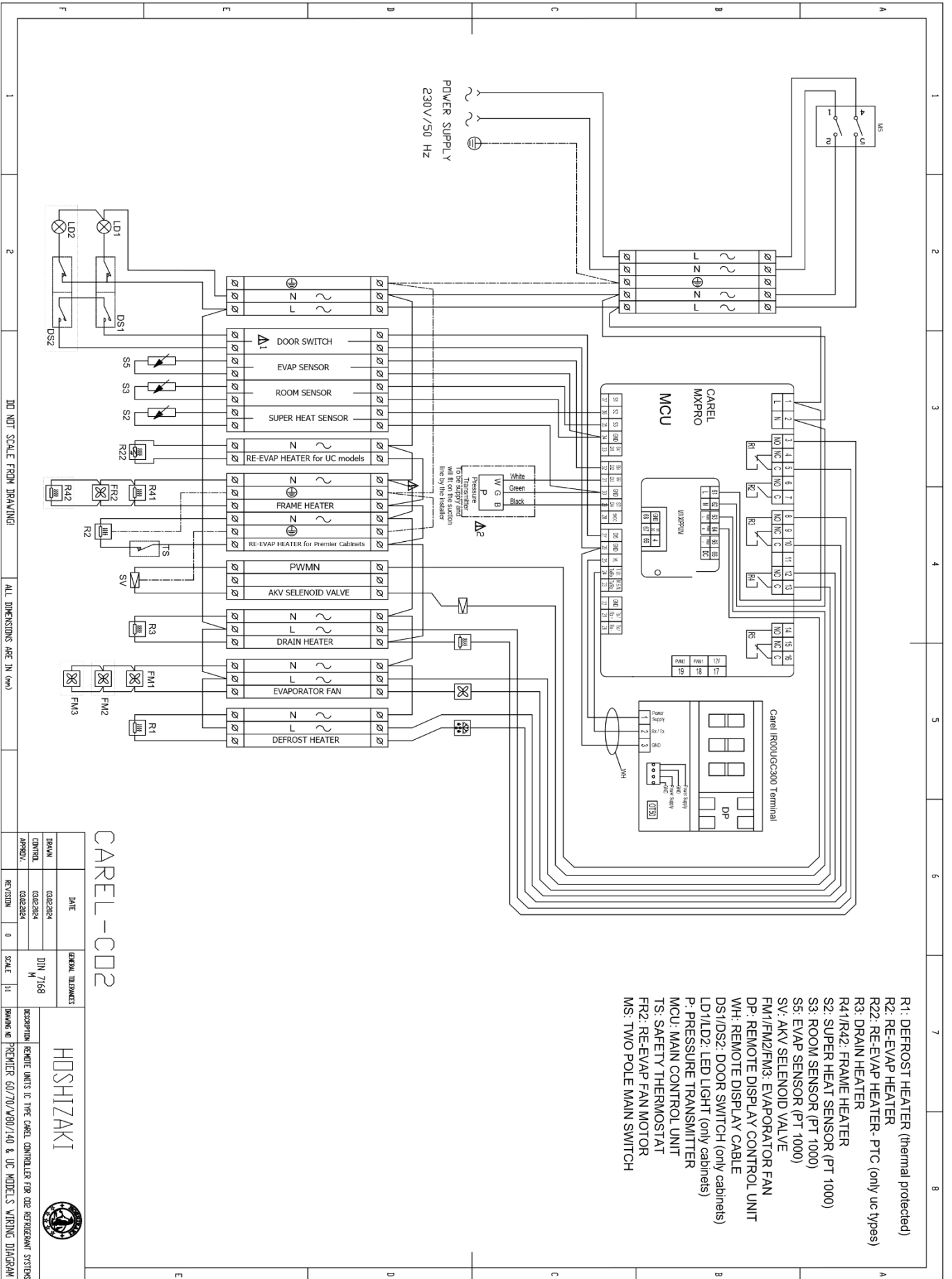

CAREL-C02

GENERAL DIMENSIONS		HOSHIZAKI	
DATE	03/02/2024	DESCRIPTION	REMOTE UNITS IC THE CAREL CONTROLLER FOR C02 RETROFIT SYSTEMS
DRAWN	03/02/2024	SCALE	1:1
CONTROL	03/02/2024	REVISION	0
APPROV.	03/02/2024		

ISSUE NO: PREMIER 60/70/80/140 & UC MODELS WIRING DIAGRAM

HOSHIZAKI

Premier Remote Cabinets

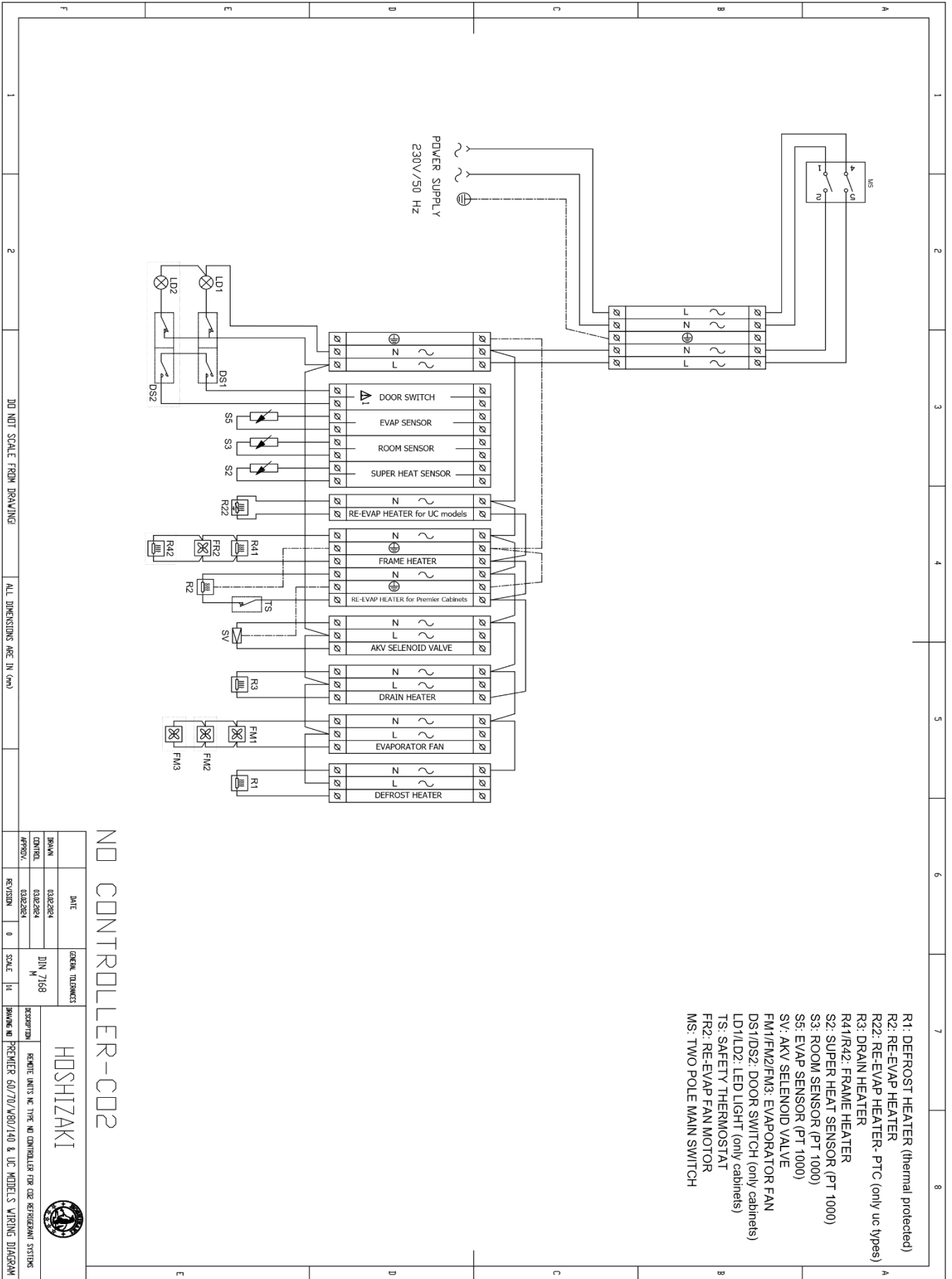

- R1: DEFROST HEATER (thermal protected)
- R2: RE-EVAP HEATER
- R22: RE-EVAP HEATER- PTC (only uc types)
- R3: DRAIN HEATER
- R41/R42: FRAME HEATER
- S2: SUPER HEAT SENSOR (PT 1000)
- S3: ROOM SENSOR (PT 1000)
- S5: EVAP SENSOR (PT 1000)
- SV: AKV SELENOID VALVE
- FM1/FM2/FM3: EVAPORATOR FAN
- DS1/DS2: DOOR SWITCH (only cabinets)
- LD1/LD2: LED LIGHT (only cabinets)
- TS: SAFETY THERMOSTAT
- FR2: RE-EVAP FAN MOTOR
- MS: TWO POLE MAIN SWITCH

NO CONTROLLER-C02

DATE		GENERAL TOLERANCES		DRAWING NO	
03/02/2014	03/02/2014	DIN 7158		PREMIER 6U/7U/8U/14U & UC MODELS WIRING DIAGRAM	
03/02/2014	03/02/2014	M		REVISION	
0	0	SCALE 1:1		APPROVAL	
DRAWN		CHECKED		APPROVED	
03/02/2014		03/02/2014		03/02/2014	
HOSHIZAKI		HOSHIZAKI		HOSHIZAKI	
KENDU UNITS NO. TYPE NO CONTROLLER FOR CDR REFRIGERANT SYSTEMS		KENDU UNITS NO. TYPE NO CONTROLLER FOR CDR REFRIGERANT SYSTEMS		KENDU UNITS NO. TYPE NO CONTROLLER FOR CDR REFRIGERANT SYSTEMS	



Schémas de Refroidissement

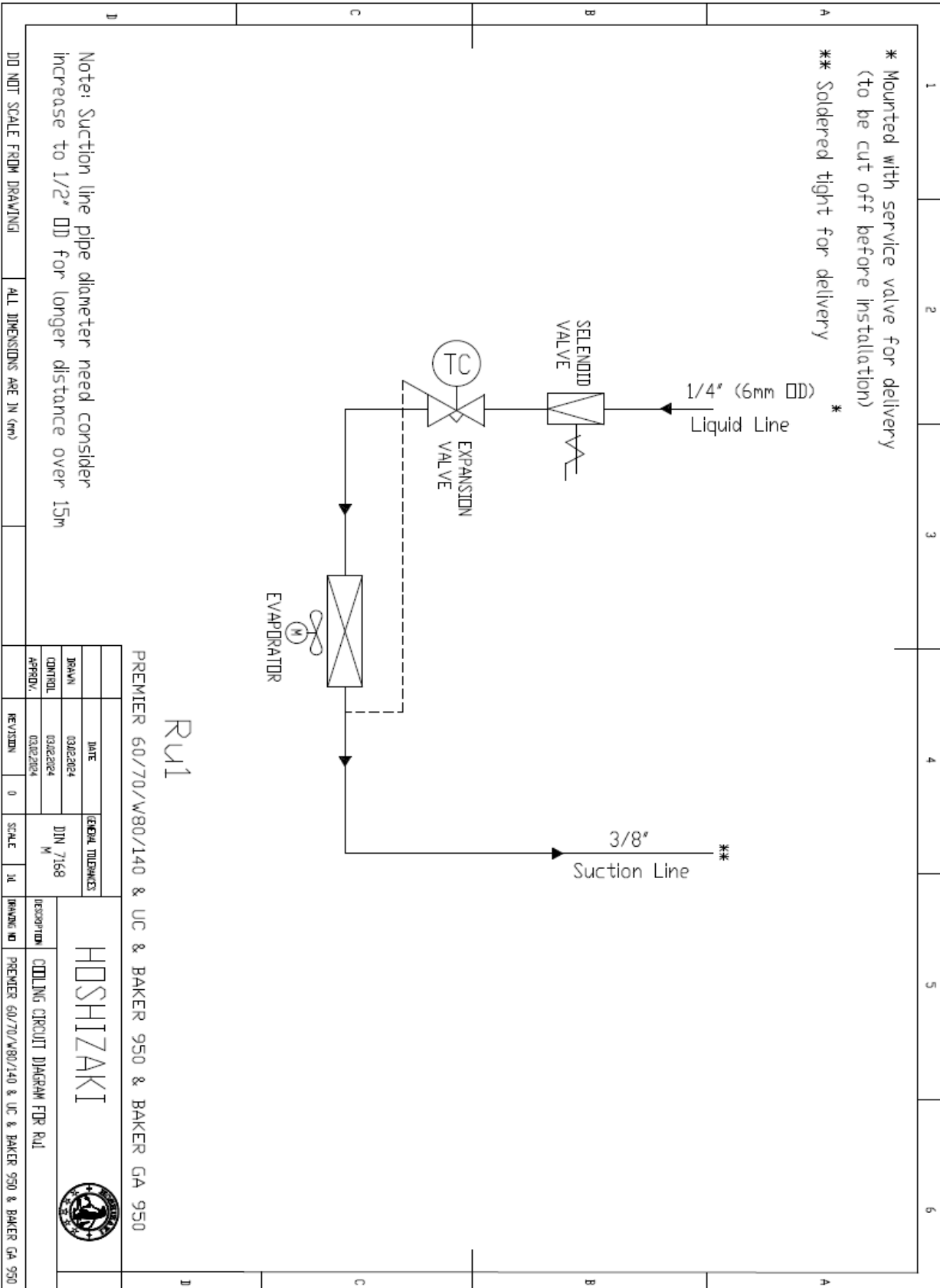

HOSHIZAKI

Premier Remote Cabinets

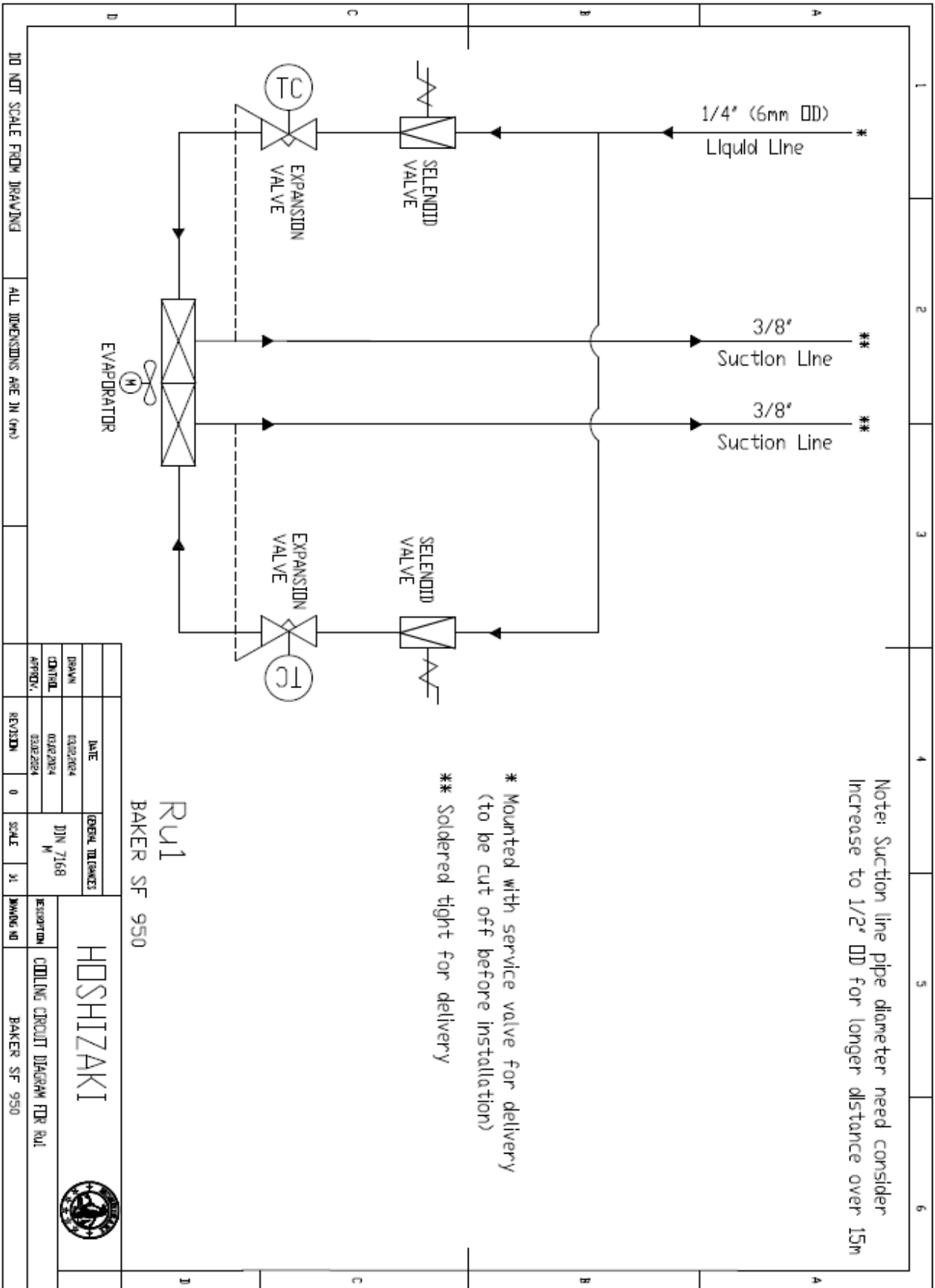



Tous droits réservés

Hoshizaki se réserve le droit de modifier les caractéristiques, ainsi que les informations présentes dans ce manuel.

Contact

Siège social

Hoshizaki Europe B.V.

TEL : +31 20 691

8499

Sales@hoshizaki.nl

<http://hoshizaki-europe.com/>

Filiales

Hoshizaki UK - Royaume-Uni, Irlande

TEL. : +44 845 456 0585

uksales@hoshizaki.co.uk

Hoshizaki Deutschland - Allemagne, Suisse, Autriche

TEL : +49 2154 92810, +49 5066 604612

info@hoshizaki.de

Hoshizaki BENELUX - Pays-Bas, Belgique, Luxembourg

TEL : +31 20 565 0420, +31 54 645 4252

sales@hoshizaki.nl

Hoshizaki France - France

TEL. : +33 1 48 63 93 80

info@hoshizaki.fr

Hoshizaki Iberia - Espagne, Portugal

TEL. : +34 93 478 09 52

info@hoshizaki.es

Hoshizaki Middle East - Moyen-Orient

TEL. : +971 48 876 612

sales@hoshizaki.ae

Hoshizaki Danmark – Danemark, Norvège, Suède

TEL : +45 8988 5350

salg@hoshizaki.dk

Hoshizaki Europe B.V.– Tous les autres pays d'Europe et d'Afrique

TEL : +31 20 565 0420

sales@hoshizaki.nl

HOSHIZAKI

Premier Remote Cabinets



MODELLE RU1 UND CO2 MIT FERNSTEUERUNG BEDIENUNGS-, WARTUNGS- UND MONTAGEANLEITUNG



**Kontakt: HOSHIZAKI
EUROPE B.V.
Adresse: Burgemeester Stramanweg 101 1101 AA Amsterdam, Niederlande
Tel.: +31 (0)20 691 84 99 – <http://hoshizaki-europe.com/>**





Inhalt

Verwendung	87
Sicherheitshinweise	88
Einbaulage.....	89
Elektrischer Anschluss	91
Allgemeine Verwendung.....	92
Betrieb des Produkts (Evco Controller – Modell RU1).....	93
Betrieb des Produkts (Danfoss Controller AK – CC55)	94
Betrieb des Produkts (Carel MPXpro Controller)	97
Betrieb des Produkts (Kein Controller – NC-Modell)	103
Fehlerbehebung	103
Tauwasser	104
Türschließmechanismus.....	104
Stromausfall.....	104
Reinigung	104
Türdichtungen.....	105
Langzeitlagerung	105
Service	105
Technische Daten.....	106
Abmessungen.....	108
Entsorgung	115
Schaltpläne.....	116
Kühlungsdiagramme.....	122



Vielen Dank, dass Sie sich für ein Qualitätsprodukt von Hoshizaki entschieden haben.

In diesem Handbuch erfahren Sie, wie Sie Ihr neues Produkt installieren, verwenden und warten.

Bevor unsere Produkte das Werk verlassen, durchlaufen sie einen vollständigen Funktions- und Qualitätstest. Sollten Sie dennoch Probleme mit dem Produkt haben, wenden Sie sich bitte an Ihren Händler vor Ort.

Hoshizaki-Niederlassungen und -Händler auf der ganzen Welt stehen Ihnen unterstützend zur Seite.

Produkte, die von Hoshizaki hergestellt werden, unterliegen unterschiedlichen Garantiebedingungen, je nach dem Land, in dem das Produkt verkauft wird. Diese Garantie setzt die ordnungsgemäße Verwendung gemäß den Spezifikationen voraus, wobei z. B. allgemeine Wartungsarbeiten und eventuelle Reparaturen von Technikern durchgeführt werden, die vom Händler benannt werden und mit dem Produkt generell vertraut sind.

Änderungen an der Installation sowie Verwendungen des Produkts, die nicht in dieser Anleitung angegeben sind, können die Funktion und Haltbarkeit des Produkts beeinträchtigen.

Das Handbuch entspricht unserem aktuellen technischen Wissensstand. Wir arbeiten ständig an der Aktualisierung dieser Informationen und behalten uns das Recht vor, technische Änderungen vorzunehmen.

Verwendung

Das Produkt ist für die Lagerung von Lebensmitteln außerhalb von Haushaltsumgebungen bestimmt.

Das Produkt ist für die Lagerung bei konstanter Temperatur bestimmt und kann nicht zum Abkühlen oder Einfrieren von heißen/frischen Lebensmitteln verwendet werden.

Das Produkt ist ausschließlich für den vorgesehenen Zweck zu verwenden. Jede andere Verwendung könnte dazu führen, dass im Produkt gelagerte Lebensmittel nicht auf der richtigen Temperatur gehalten werden oder sogar das Produkt beschädigt wird.

Das Produkt eignet sich nicht zur Aufbewahrung von Blutplasma, Laborproben, Arzneimitteln oder ähnlichen Stoffen.

Der Hersteller übernimmt keine Haftung oder Verantwortung für Schäden, die durch missbräuchliche, falsche oder unangemessene Verwendung des Produkts verursacht werden.

Sicherheitshinweise

Wichtig

Beschreibung der in diesem Handbuch verwendeten Symbole.



Warnung Die Nichtbeachtung dieser Anweisungen kann zu Unfällen mit Personenschäden führen.



Wichtig Werden diese Anweisungen nicht befolgt, kann das Produkt beschädigt oder zerstört werden.

Beachten Sie, dass Hoshizaki Vorkehrungen getroffen hat, um die Sicherheit des Produkts zu gewährleisten.

Bitte lesen Sie die folgenden Sicherheitsinformationen sorgfältig durch.



Es ist wichtig, dass jeder, der das Produkt benutzen oder installieren soll, Zugang zu diesem Handbuch hat.



Dieses Gerät darf nicht von Personen benutzt werden, deren physische, sensorische oder mentale Fähigkeiten eingeschränkt sind oder die über keine Erfahrung und kein Wissen verfügen, es sei denn, sie werden von einer für ihre Sicherheit verantwortlichen Person bei der Benutzung des Gerätes beaufsichtigt oder angeleitet.



Kinder sollten beaufsichtigt werden, um sicherzustellen, dass sie mit dem Gerät nicht spielen.



Das Gerät kann Teile mit scharfen Kanten im Kompressorraum und im Innenraum enthalten.



Das Gerät darf nicht auf einem Sackkarren transportiert werden; es besteht die Gefahr des Gleichgewichtsverlusts, wodurch Personen gefährdet werden.



Ziehen Sie nicht am Netzkabel, um das Gerät von der Stromversorgung zu trennen, oder wenn das Gerät bewegt wird.

Einbaulage

Prüfen Sie das Verpackungsmaterial bei Erhalt des Produkts auf Beschädigungen.

Falls am Verpackungsmaterial Schäden vorliegen, sollte geprüft werden, ob die Theke ebenfalls beschädigt wurde. Sollte der Schaden erheblich sein, wenden Sie sich bitte an Ihren Händler.



Diese Aufgabe erfordert mindestens 2 Personen. Der schwerste Teil des Produkts befindet sich oben. Beachten Sie dies, wenn Sie die Transportpalette entfernen.



Aufgrund des hohen Gewichts des Produkts kann der Boden beim Bewegen des Produkts beschädigt oder zerkratzt werden.



Die korrekte Einrichtung sorgt für den effektivsten Betrieb.



Das Produkt sollte sich in einem trockenen und ausreichend belüfteten Raum befinden.



Um einen effizienten Betrieb zu gewährleisten, darf es nicht in direktem Sonnenlicht oder in der Nähe von wärmeabgebenden Oberflächen aufgestellt werden. Das Produkt ist für den Betrieb bei einer Umgebungstemperatur zwischen +16 °C und +40 °C ausgelegt.



Vermeiden Sie es aufgrund der Korrosionsgefahr, das Produkt in einer chlor-/säurehaltigen Umgebung (Schwimmbad usw.) aufzustellen.



Das Produkt und Teile des Innenraums sind mit einer Schutzfolie ausgestattet, die vor der Verwendung entfernt werden sollte.



Reinigen Sie das Produkt vor der Anwendung mit einer milden Seifenlösung.

Der Aufstellort muss eben und horizontal sein.

Verwenden Sie bei Versionen mit Beinen die verstellbaren Beine, um sicherzustellen, dass das Produkt eben und aufrecht steht.

Bei Ausführungen mit Rollen müssen die Verriegelungsvorrichtungen der beiden vorderen Rollen aktiviert werden, wenn das Produkt an Ort und Stelle ist.

HOSHIZAKI

Premier Remote Cabinets



Für Servicearbeiten muss über dem Produkt stets 500 mm freier Raum vorhanden sein.

Das Produkt sollte so nah wie möglich an die Wand gestellt werden.

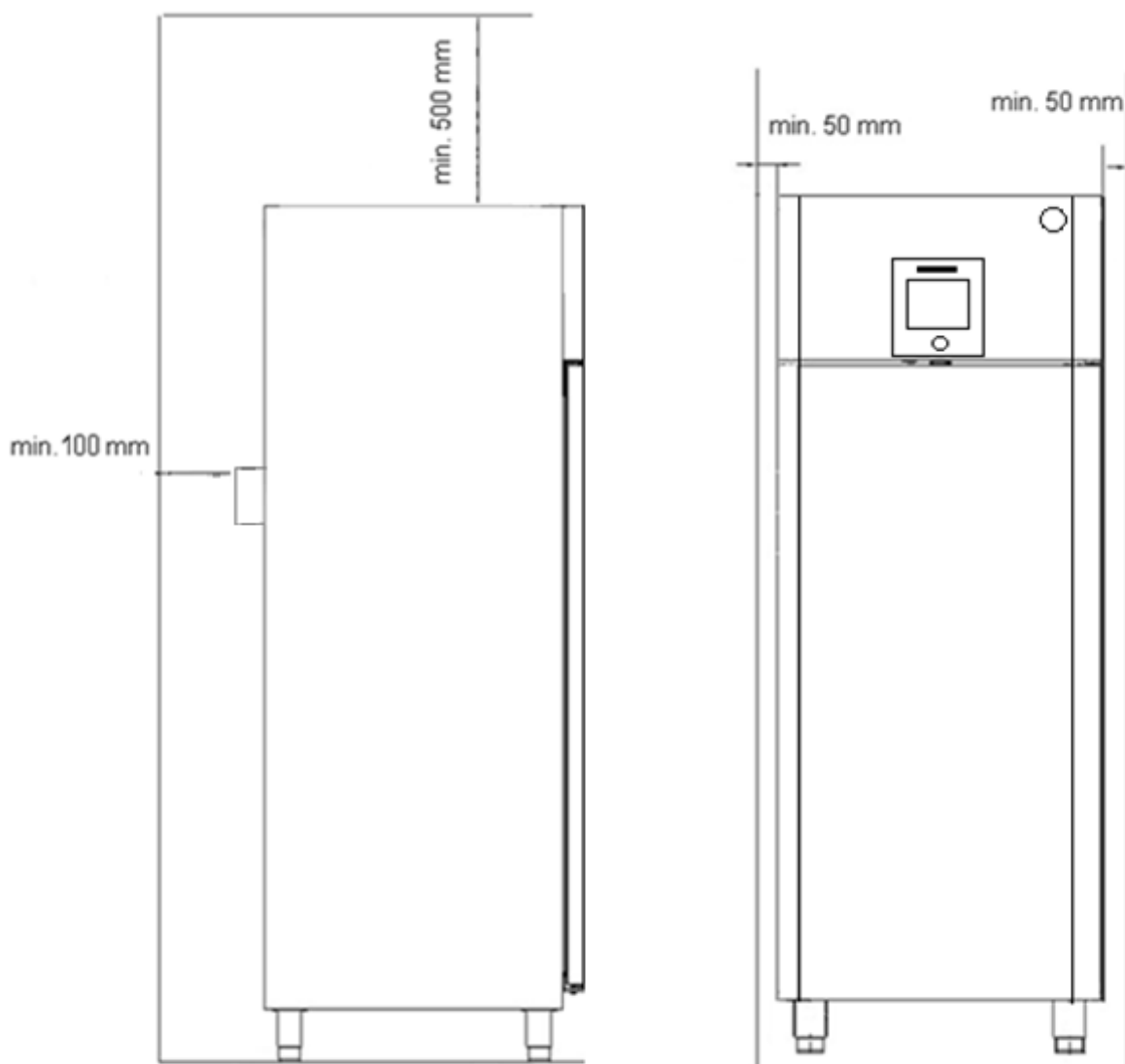

Elektrischer Anschluss

Lesen Sie den unten stehenden Text gründlich, bevor der elektrische Anschluss vorgenommen wird.



Das Produkt ist für den Anschluss an Wechselstrom bestimmt. Die Anschlussspannung (V) und Frequenz (Hz) sind auf dem Typenschild im Schrank angegeben.



Verwenden Sie niemals ein Verlängerungskabel für dieses Gerät!

Wenn die Wandsteckdose sich in einem größeren Abstand als die Länge des mitgelieferten Stromkabels befindet, kontaktieren Sie einen Elektriker, um eine Wandsteckdose innerhalb der Reichweite des Stromkabels zu installieren.



Ist das Produkt defekt, **sollte es von einem qualifizierten Servicetechniker** untersucht werden, der mit der installierten Regeleinheit vertraut ist und Erfahrung in der Wartung des CO₂-Schranks hat.



Im Allgemeinen muss es von dem Unternehmen geprüft werden, das das Produkt angeschlossen hat.



Trennen Sie die Stromversorgung immer, wenn Unterbrechungen in der Stromversorgung auftreten, wenn elektrische Teile entfernt/angeschlossen werden, und vor der Reinigung und Wartung des Produkts.



Verwenden Sie das Produkt nicht, ohne dass alle Schutzteile installiert sind, um Berührung mit aktiven oder rotierenden Maschinenteilen zu vermeiden.

Das Produkt darf nicht im Freien verwendet werden.



Alle von den örtlichen Aufsichtsbehörden für Elektroeinrichtungen vorgeschriebenen Erdungsanforderungen sind einzuhalten. Der Stecker und die Wandsteckdose müssen für eine ordnungsgemäße Erdung sorgen. Wenden Sie sich bei Bedarf an einen Elektriker.



Stellen Sie sicher, dass das Produkt an der Steckdose abgeschaltet wird oder der Kaltgerätestecker abgezogen ist, bevor Servicearbeiten an elektrischen Teilen durchgeführt werden. Es reicht nicht aus, das Produkt über den Controller abzuschalten.

Allgemeine Verwendung



Die Teile des Kältekreislaufs dürfen nicht beschädigt werden.



Wenn das Produkt mit einer Rückverdampfungsschale unter dem Schrank ausgestattet ist, ist es wichtig, die Schale oder die Heizung nicht zu warten/zu reinigen, bevor der Schrank lange genug abgeschaltet wurde, um sicherzustellen, dass die Rückverdampfungsheizung abgekühlt ist, um die Gefahr von Verbrennungen zu vermeiden.



Betreiben Sie im Inneren des Produkts keine elektrischen Geräte.



Um einen korrekten und effizienten Luftstrom im Schrank zu gewährleisten, dürfen Gegenstände niemals außerhalb der dafür vorgesehenen Bereiche abgestellt werden.



Alle zu lagernden Gegenstände, die nicht umhüllt oder verpackt sind, müssen abgedeckt werden, um unnötige Korrosion der Schrankinnenteile zu vermeiden.



Wenn Controller-Parameter abweichend vom Standard geändert werden, kann dies dazu führen, dass das Produkt nicht normal funktioniert, und schädliche Temperaturen könnten die Artikel im Inneren des Produkts beschädigen.



Maximale Fach-Belastung: 40 kg



Lagern Sie keine explosiven Stoffe wie Spraydosen mit einem brennbaren Treibmittel in diesem Schrank.



Stellen Sie keine Produkte unter der unteren Ablage oder über der oberen Ladelinienmarkierung auf.

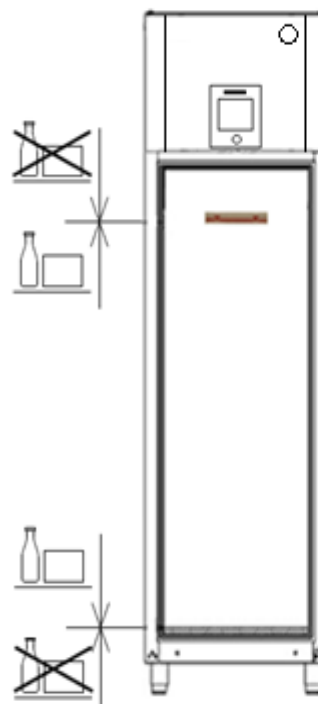

Do not store goods above the top loading mark

Do not store goods below the bottom grate

Betrieb des Produkts (Evco Controller – Modell RU1)

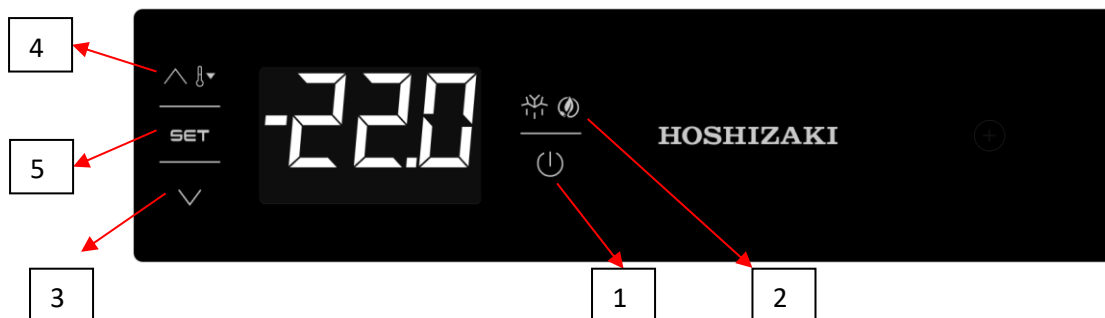

➤ FUNKTIONEN AN DER FRONTPLATTE

Zum Sperren der Tasten am vorderen Bedienfeld AUX (3) gedrückt halten und Ein / Standby (1) 2 Sekunden lang gedrückt halten: Wenn die Tasten gesperrt sind, wird die Angabe „Loc“ angezeigt; sind sie nicht verriegelt, wird die Angabe „UnL“ angezeigt.

1) Das Gerät kann geöffnet oder geschlossen werden, indem **EIN/STANDBY** 4 Sekunden lang gedrückt gehalten wird. (Ein/Aus)

2) **MANUELLES ABTAUEN**: Wird diese Taste 4 Sekunden lang gedrückt, so beginnt die manuelle Abtauung. Allerdings startet die manuelle Abtauung nicht im Falle der Starkkühlung und einer ungeeigneten Verdampfer Temperatur.

3) **ABWÄRTS**-Taste: Zum Durchlaufen des Menüs nach unten oder Reduzieren eines Werts. Wird diese Taste 4 Sekunden lang gedrückt, aktiviert dies die Superkühlung. Bei aktiver Starkkühlungsfunktion kann die eingestellte Temperatur gesenkt werden; Zeit und Temperatur werden anhand der Parameter bestimmt. Bei aktiver Starkkühlungsfunktion findet keinerlei Abtauung statt.

4) **AUFWÄRTS**-Taste: Zum Durchlaufen des Menüs nach oben oder Erhöhen eines Werts. Wird diese Taste 4 Sekunden lang gedrückt, so aktiviert dies die Funktion für geringen und hohen relativen Luftfeuchtigkeitsgehalt. (Nur bei einigen Modellen) Die Anzeige „rhL“ erscheint (Funktion für geringe relative Luftfeuchtigkeit ist aktiv) oder die Anzeige „rhH“ erscheint (Funktion für hohe relative Luftfeuchtigkeit ist aktiv). Diese Funktionen werden 10 Sekunden lang angezeigt. Falls keine Luftfeuchtigkeitssteuerung stattfindet, erscheint 1 Sekunde lang die Anzeige „----“.

5) **SET**-Taste: Eingabe- und Änderungstaste für einstellbare Werte.

➤ BETRIEB

Folgende Betriebssituationen existieren:

Status „**Ein**“: Das Gerät wird mit Strom versorgt und arbeitet.

Status „**Standby**“: Das Gerät ist ausgeschaltet, wird aber weiterhin mit Strom versorgt.

Status „**Aus**“: Zum Ausschalten des Geräts den Stecker aus der Steckdose ziehen oder die Hauptsicherung ziehen.

Betrieb des Produkts (Danfoss Controller AK – CC55)





Inbetriebnahme:

Stecken Sie den Netzstecker des Geräts ein.

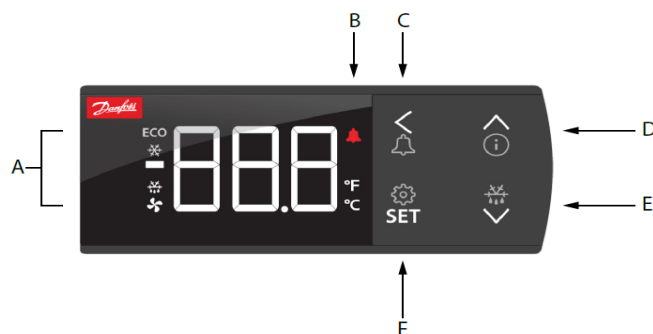
Stellen Sie sicher, dass der 2-polige Hauptschalter sich in der Stellung „Ein“ befindet.

Erläuterung der Anzeige (AK-UI55):



Teile der Anzeige	Beschreibung
A	Leuchtet bei:  - Energieoptimierung (ECO)  - Kühlung  - Abtauen  - Lüfterbetrieb
B	Leuchtet bei Alarm
C	Durch langes Drücken (3 Sekunden) des Alarmknopfes (Relais wird zurückgesetzt) wird der Alarmcode angezeigt.
D	Durch langes Drücken (3 Sekunden) wird das Informationsmenü „ Inf “ aufgerufen. (Siehe Abbildung „ b “) Pfeil nach oben / Pfeil nach unten / Pfeil nach links: Navigation im Menü und Einstellung von Werten.
E	Durch langes Drücken (3 Sekunden) wird eine Abtauung gestartet, „ d “ erscheint in der Anzeige. Eine laufende Abtauung kann durch langes Drücken gestoppt werden.
F	SET: Durch langes Drücken (3 Sekunden) wird das Menü „ SET “ aufgerufen. Ist der Vorgang mit einem Passwort gesperrt, wird „ PS “ angezeigt. Geben Sie den Code ein. * Zeigt die Einstellung für einen gewählten Parameter an / speichert eine geänderte Einstellung. Kurzes Drücken ermöglicht das Aufrufen der Abschaltgrenze des Thermostats.

* Die werkseitige Einstellung von P89 ist „0“, dieser Schritt wird ohne Eingabewerte übersprungen.



a- Parameterliste „SET“-Taste

b – Parameterliste „Info“-Taste

SET	←	SET button, 3 s: Configuration settings
Set		
(PS) v	←	PS: Password (if any)
cFg	SET →	
v		
r--		
A--		
c--		
d--		
n--		
F--		
t--		
h--		
o--		
p--		
q--		
u--		
<		
(Return)		

Menu groups
See also the following pages.

r12	Main switch
o61	Application
o03	MODBUS address
r89	Food type
r00	Cut-out temperature
r15	Ther. sensor S4 %
r61	Ther. sensor S4% night
A36	Alarm sensor S4%
o17	Display air S4%
o30	Refrigerant type
o20	Min. transmitter range
o21	Max. transmitter range
d01	Defrost method
d03	Defrost interval
d10	Defrost sensor
d04	Max. defrost time
d02	Defrost stop temperature
<	
(Return)	

^	←	Info button, 3 s: Information for service use
Inf		
StA	SET	See control state message
App	SET	See selected application
in	SET →	
out	SET →	
buS	SET	MODBUS quality
SoF	SET	See SW version
<		
(Return)		

do1	*	Read output status
do2	*	
do3	*	
do4	*	
Ao1	**	
<		(Return)

Output status
When you want info on a relay output, the dot will show whether the relay is activated (energized)
for e.g.:
do4 = not activated
do.4 = activated

Al1	(PE)	Read input status
Al2	**	
Al3	**	
Al4	**	
Al5	**	
di1	**	
di2	**	
<		(Return)

Fehlermeldung (Alarme)



In einer Fehlersituation leuchtet die Alarm-LED an der Vorderseite und das Alarm-Relais wird aktiviert (je nach Priorität). Wenn Sie den Alarmknopf 3 Sekunden lang drücken, sehen Sie den Alarmbericht auf der Anzeige.

Weitere Informationen entnehmen Sie bitte dem Handbuch des ausgewählten CO₂-Controllers. (Danfoss AK-CC55 Compact)

Code	Alarm text	Description
E01	Hardware failure	The controller has a hardware failure
E06	Clock lost time	Clock has lost valid time
E20	Pe Evap. pressure A - Sensor error	Sensor signal is out of range. Please check the sensor for correct operation
E24	S2 Gas outlet A - Sensor error	Sensor signal is out of range. Please check the sensor for correct operation
E25	S3 Air ON evap. A - Sensor error	Sensor signal is out of range. Please check the sensor for correct operation
E26	S4 Air OFF evap. A - Sensor error	Sensor signal is out of range. Please check the sensor for correct operation
E27	S5 Evaporator A - Sensor error	Sensor signal is out of range. Please check the sensor for correct operation
A01	High temperature alarm A	The alarm temperature has been above the max alarm limit for a longer time period than the set alarm delay.
A02	Low temperature alarm A	The alarm temperature has been below the min alarm limit for a longer time period than the set alarm delay.
A04	Door open alarm	The door has been open for a too long time
A05	Max defrost hold time exceeded	The controller has been waiting longer time than permitted after a co-ordinated defrost.
A11	Refrigerant not selected	The refrigerant has not been selected hence control can not be initiated
A15	DI alarm 1	Alarm signal from digital input signal
A16	DI alarm 2	Alarm signal from digital input signal
A45	Main switch set OFF	The controller main switch has been set to either Stop or Manual control. Alternatively a digital input set up for "main switch" function, has stopped control
A59	Case in cleaning mode	A case cleaning operation has been started on a case
AA2	CO ₂ leak detected	CO ₂ is leaking from the refrigeration system
AA3	Refrigerant leak detected	Refrigerant is leaking from the refrigeration system
a04	Wrong IO configuration	Inputs and outputs have not been configured correctly

Betrieb des Produkts (Carel MPXpro Controller)

Inbetriebnahme

Stecken Sie den Netzstecker des Geräts ein.

Standardmäßig wird der Schrankcontroller eingeschaltet geliefert. Das bedeutet, dass der Controller mit der Regelung beginnt, wenn das Netzteil angeschlossen wird und der Hauptschalter sich in der Stellung „Ein“ befindet.

Ein-/Ausschalten des Schanks

Zum Ein-/Ausschalten des Schanks wird der 2-polige Hauptschalter verwendet, der sich auf der linken Seite des Hauptsteuerkastens im „Kompressorraum“ befindet.

Die Anzeige

Layout/Erläuterung der Anzeige:



Die oben abgebildete Anzeige zeigt drei Ziffern an.

Innerhalb des Anzeigebereichs sind mehrere LEDs platziert. Diese LEDs geben folgende Hinweise:

Generell = Wenn eine LED blinkt, wird die Aktivierung verzögert oder eingeschränkt.

 = Kühlung ein (wenn diese LED leuchtet, ist die Kühlung eingeschaltet)

 = Innenlüfter läuft (wenn diese LED leuchtet, ist der interne Lüfter/Verdampferlüfter eingeschaltet)

 = Abtauen ein (wenn diese LED leuchtet, läuft ein Abtauzyklus)

 = Wenn die LED blinkt, bedeutet dies, dass die Tür geöffnet ist oder ein Alarm oder ein Fehler vorliegt.

HACCP = Wenn diese LED leuchtet, liegt ein HACCP-Alarm vor. Wenn diese LED blinkt, liegt ein gespeicherter HACCP-Alarm vor.

Tasten:

Die 4 Tasten auf der rechten Seite der Anzeige dienen dem Zugriff auf und der Einstellung von verschiedenen Parametern. Diese Tasten können allein oder in Kombination gedrückt werden, um den Controller zu bedienen.

Die unten erläuterten Einstellungen sind die einzigen, die vom Endbenutzer geändert werden sollten. Der Endbenutzer sollte keine Parameter ändern, die hier nicht erläutert werden. Alle anderen Einstellungen sollten von einem qualifizierten Techniker vorgenommen werden.

BENUTZEREINSTELLUNGEN

Einstellung des Schranktemperatur-Sollwerts

 :Aufwärts  : Abwärts  :Set  : Prg/mute

- Halten Sie während des normalen Betriebs die Taste Set gedrückt, bis die Anzeige zu blinken beginnt. Der Sollwert der Schranktemperatur kann mit Aufwärts und Abwärts eingestellt werden.
- Wurde der Sollwert auf die gewünschte Temperatur eingestellt, drücken Sie kurz Set , um den neuen Wert zu speichern und zum Normalbetrieb zurückzukehren.

Durchführen einer manuellen Abtauung

- Halten Sie def während des normalen Betriebs länger als 5 Sekunden gedrückt, um eine manuelle Abtauung durchzuführen, wenn die Verdampferoberflächentemperatur kalt genug ist.
- Wenn das Abtausymbol  leuchtet, bedeutet dies, dass ein Abtauzyklus stattfindet.
- Wenn def gedrückt und länger als 5 Sekunden gehalten wird, während ein Abtauzyklus läuft, wird die Abtauung deaktiviert.

Stummschalten der akustischen Alarme

- Wenn sich der Controller im Alarmmodus befindet, hören Sie ein akustisches Signal. Der Alarm kann durch Drücken von Prg/mute stummgeschaltet werden.



Einstellung der Alarmgrenzwerte für die Temperatur

- Halten Sie während des normalen Betriebs die Taste Prg/mute länger als 5 Sekunden gedrückt, um die Parameterliste zu öffnen. Die Anzeige zeigt **/c1**.
- Drücken Sie auf Prg/mute . Die erste Kategorie von Parametern, „Pro“, wird angezeigt.
- Drücken Sie auf AUFWÄRTS , bis die Kategorie „ALn“ erreicht ist, die durch das Symbol  angezeigt wird, das auf der Anzeige aufleuchtet.
- Bei Drücken auf Set wird Parameter AA angezeigt.
- Drücken Sie auf AUFWÄRTS, bis A1 erreicht ist.
- Drücken Sie auf Set , um einzustellen, ob die Einstellungen AL (**A**larm **L**ow Temperature Threshold (Alarm Niedrigtemperaturschwelle)) und AH (**A**larm **H**igh Temperature Threshold (Alarm Hochtemperaturschwelle)) 0 (= relativ zu den Schranktemperatur-Sollwerten) oder 1 (= absolut) sein sollten. Standardeinstellung = 1
- Drücken Sie auf Set, um die gewählte Einstellung zu speichern und zu A1 zurückzukehren.
- Drücken Sie auf AUFWÄRTS, bis AL (**A**larm **L**ow Temperatur Threshold (Alarm Niedrigtemperaturschwelle)) erreicht ist.
- Drücken Sie auf Set, um die Einstellung von AL mit Aufwärts und Abwärts zu ermöglichen (einstellbar zwischen -50 und +50). Standardeinstellung = -50 °C
- Drücken Sie auf Set, um die gewählte Einstellung zu speichern und zu AL zurückzukehren.
- Drücken Sie auf AUFWÄRTS, bis AH (**A**larm **H**igh Temperature Threshold (Alarm Hochtemperaturschwelle)) erreicht ist.
- Mit Drücken der Taste Set kann AH mit Aufwärts und Abwärts eingestellt werden (einstellbar zwischen -50 und +50). Standardeinstellung = +50 °C
- Drücken Sie auf Set, um die gewählte Einstellung zu speichern und zu AH zurückzukehren.
- Drücken Sie AUFWÄRTS, bis AD (**A**larm **D**elay Time (Alarmverzögerungszeit) für AL und AH) erreicht ist.
- Drücken Sie die Taste Set, um die Einstellung von Ad mit Aufwärts und Abwärts zu ermöglichen (einstellbar zwischen 0 und 240 Minuten). Standardeinstellung = 120 Minuten



- Drücken Sie auf Set, um die gewählte Einstellung zu speichern und zu Ad zurückzukehren.
- Halten Sie Prg/mute für mehr als 5 Sekunden gedrückt, um die Änderungen zu speichern, und kehren Sie dann zum Hauptmenü zurück.

Um für einen Kühl- oder Gefrierschrank geeignete Temperaturalarmschwellen und Alarmverzögerungszeiten zu erzeugen, werden die folgenden beispielhaften Alarmeinstellungen vorgeschlagen:

	Sollwert	A1	AL	AH	Ad
Kühlschrank	+5 °C	1	+1 °C	+8 °C	120 Min.
Gefriergerät	-18 °C	1	-50 °C	-15 °C	120 Min.

Aufrufen des Alarmprotokolls

- Drücken Sie auf Prg/mute und Set und halten Sie die Tasten 5 Sekunden lang gedrückt.
- Geben Sie das Kennwort ein: 44.
- Drücken Sie auf Set, um auf ein Untermenü zuzugreifen, in dem mit AUFWÄRTS und ABWÄRTS durch die verschiedenen Alarme HS0 bis HS9 geblättert werden kann.
- Wählen Sie einen Alarm aus und drücken Sie auf Set, um den Code, die Stunde, die Minuten und die Dauer anzuzeigen.
- Drücken Sie von einem der Sub-Parameter aus auf Prg/mute, damit der Controller zum übergeordneten Parameter „HSx“ zurückkehrt.
- Drücken Sie 5 Sekunden lang auf Prg/mute, um zur

Standardanzeige zurückzukehren. Beispiel:

„HI“ -> „h17“ -> „m23“ -> „65“

zeigt an, dass der Alarm „HI“ (Hochtemperaturalarm) um 17:23 Uhr aktiviert wurde und 65 Minuten dauerte.

HACCP-ALARME

Es werden zwei Arten von HACCP-Ereignissen verwaltet:

- HA-Alarme, hohe Temperatur während des Betriebs;
- HF-Alarme, hohe Temperatur nach Stromausfall (Blackout).

Wenn ein Alarm aufgezeichnet wird, blinkt die HACCP-LED, die Anzeige zeigt den Alarmcode an, der Alarm wird gespeichert und das Alarmrelais und der Summer werden aktiviert.

So rufen Sie HA- und HF-Alarme auf

- Drücken Sie gleichzeitig auf Prg/mute und ABWÄRTS.



- Blättern Sie durch die Liste der Alarme, indem Sie auf AUFWÄRTS und ABWÄRTS drücken.
- Drücken Sie auf Set , um den gewünschten Alarm auszuwählen.
- Verwenden Sie AUFWÄRTS oder ABWÄRTS , um die Beschreibung des Alarms anzuzeigen: Jahr, Monat, Tag, Uhrzeit in Stunden und Minuten sowie Dauer in Minuten des ausgewählten Alarms.
- Drücken Sie erneut auf Prg/mute , um zur vorherigen Liste zurückzukehren.

Das HACCP-Alarmmenü ermöglicht außerdem folgende Funktionen:

Einen HACCP-Alarm löschen

- Drücken Sie 5 Sekunden lang auf Set und ABWÄRTS , wenn die Liste der Alarme angezeigt wird.

Dadurch beginnt HACCP zu blinken, die Anzeige zeigt die Meldung „rES“ und die Überwachung der HACCP-Alarme wird neu initialisiert.

Alle gespeicherten HACCP-Alarme löschen

- Drücken Sie 5 Sekunden lang auf Set und AUFWÄRTS und ABWÄRTS .
Dadurch wird die Meldung „rES“ angezeigt, der gesamte Alarmspeicher gelöscht und die Überwachung der HACCP-Alarme neu initialisiert.

Um die HACCP-Alarme nutzen zu können, ist es notwendig, dass die Echtzeituhr vor der Übergabe des Schrankes an den Endverbraucher durch das installierende Unternehmen eingestellt wurde. Diese Einstellungen sind durch einen Zugangscode geschützt und können daher vom Endbenutzer nicht vorgenommen werden.

Schrankleuchte

Bei allen Schränken ist die Schrankleuchte außen über der Tür am Schrank angebracht. Diese Leuchte wird vom Hauptcontroller gesteuert, was bedeutet, dass ihre Funktionsweise nicht geändert werden kann.

Wenn die Schranktür geöffnet wird, schaltet sich die Leuchte über der Tür ein. Beim Schließen der Tür schaltet sich die Schrankleuchte über der Tür aus.

Fehler und Alarme

Display code	Cause of the alarm	Icon flash on display	Alarm relay	Buzzer	Reset	Compressor	Defrost	Evaporator fans	Continuous cycle	Signalled on tLAN	Network solenoid valve
rE	Control probe fault		ON	ON	automatic	duty setting(c4)	unchanged	unchanged	unchanged	√	-
E1	Probe S1 fault		OFF	OFF	automatic	duty setting(c4)	unchanged	unchanged	unchanged	√	-
E2	Probe S2 fault		OFF	OFF	automatic	unchanged	unchanged	unchanged	unchanged	√	-
E3	Probe S3 fault		OFF	OFF	automatic	unchanged	unchanged	unchanged	unchanged	√	-
E4	Probe S4 fault		OFF	OFF	automatic	unchanged	unchanged	unchanged	unchanged	√	-
E5	Probe S5 fault		OFF	OFF	automatic	unchanged	unchanged	unchanged	unchanged	√	-
E6	Probe S6 fault		OFF	OFF	automatic	unchanged	unchanged	unchanged	unchanged	√	-
E7	Probe S7 fault		OFF	OFF	automatic	unchanged	unchanged	unchanged	unchanged	√	-
E8	Serial probe S8 not updated		OFF	OFF	automatic	duty setting(c4)	unchanged	unchanged	unchanged	√	-
E9	Serial probe S9 not updated		OFF	OFF	automatic	duty setting(c4)	unchanged	unchanged	unchanged	√	-
E10	Serial probe S10 not updated		OFF	OFF	automatic	duty setting(c4)	unchanged	unchanged	unchanged	√	-
E11	Serial probe S11 not updated		OFF	OFF	automatic	duty setting(c4)	unchanged	unchanged	unchanged	√	-
LO	Low temperature alarm		ON	ON	automatic	unchanged	unchanged	unchanged	unchanged	√	-
HI	High temperature alarm		ON	ON	automatic	unchanged	unchanged	unchanged	unchanged	√	-
LO2	Low temperature alarm		ON	ON	automatic	unchanged	unchanged	unchanged	unchanged	√	-
HI2	High temperature alarm		ON	ON	automatic	unchanged	unchanged	unchanged	unchanged	√	-
IA	Immediate alarm from external contact		ON	ON	automatic	duty setting(A6)	unchanged	unchanged	unchanged	√	-
dA	Delayed alarm from external contact		ON	ON	automatic	duty setting(A6) if A7≠0	unchanged	unchanged	unchanged	√	-
dor	Door open for too long alarm		ON	ON	automatic	unchanged	unchanged	unchanged	unchanged	√	-
Etc	Real time clock fault		OFF	OFF	automatic	unchanged	unchanged	unchanged	unchanged	√	-
LSH	Low superheat alarm		OFF	OFF	automatic	OFF	unchanged	unchanged	unchanged	√	√
LSA	Low suction temperature alarm		OFF	OFF	automatic / manual	OFF (paragraph 6.10)	unchanged	unchanged	unchanged	√	√
MOP	Maximum evaporation pressure alarm		OFF	OFF	automatic	OFF	unchanged	unchanged	unchanged	√	√
LOP	Low evaporation temperature alarm		OFF	OFF	automatic	unchanged	unchanged	unchanged	unchanged	√	√
bLo	Valve blocked alarm		OFF	OFF	manual/ disabled with P14=0	unchanged	unchanged	unchanged	unchanged	√	-
Edc	Communication error with stepper driver		ON	ON	automatic	unchanged	unchanged	unchanged	unchanged	√	-
EFS	Stepper motor broken/not connected		ON	ON	automatic	unchanged	unchanged	unchanged	unchanged	√	-
EE	Flash unit parameter error		OFF	OFF	automatic	OFF	not performed	OFF	not performed	√	-
EF	EEPROM operating parameter error		OFF	OFF	automatic	OFF	not performed	OFF	not performed	√	-
HA	Type HA HACCP alarm	HACCP	OFF	OFF	manual	unchanged	unchanged	unchanged	unchanged	√	-
HF	Type HF HACCP alarm	HACCP	OFF	OFF	manual	unchanged	unchanged	unchanged	unchanged	√	-
MA	Communication error with Master (only on Slave)		ON	ON	automatic	unchanged	unchanged	unchanged	unchanged	-	-
u1...u5	Communication error with Slave (only on Master)		ON	ON	automatic	unchanged	unchanged	unchanged	unchanged	-	-
n1...n5	Alarm on unit 1 to 5 in the network		ON	ON	automatic	unchanged	unchanged	unchanged	unchanged	-	-
up1...up5	Upload procedure with errors on unit 1 to 5		OFF	OFF	-	unchanged	unchanged	unchanged	unchanged	-	-
GPE	Error in custom gas parameters		ON	ON	automatic	OFF	not performed	OFF	not performed	√	-



Weitere Informationen entnehmen Sie bitte dem Handbuch des ausgewählten CO2-Controllers. (Carel MPX PRO)

Betrieb des Produkts (Kein Controller – NC-Modell)



Bitte lesen Sie die Bedienungsanleitung, die mit dem installierten Controller geliefert wird.

Fehlerbehebung

Geräusche:

- Wenn ungewöhnliche Geräusche auftreten, wenden Sie sich an den Kundendienst.
- Die Betriebsgeräusche des Innenlüfters sind normal.
- Wenn Blechteile, Frontblenden oder Blenden vor dem Fach Geräusche machen, sind diese möglicherweise offen. Schließen Sie die Blenden.

Eisbildung im Innenraum:

- Umgebungsluftfeuchtigkeit zu hoch.
- Die Tür wird zu oft geöffnet.
- Die Tür wird zu lange offen gelassen.
- Beschädigte Türdichtung. Überprüfen Sie sie gründlich auf Beschädigungen.

Schlechte Kühlleistung:

- Raumtemperatur zu hoch.
- Die Tür wird zu oft und/oder zu lange geöffnet.
- Die Tür wird offen gelassen.
- Beschädigte Türdichtung.
- Temperatureinstellung zu hoch.
- Zu viele Lebensmittel verstaut – Luftein-/auslass blockiert.
- Warme oder heiße Lebensmittel im Schrank.
- Abtauen läuft. Die Schranktemperatur kann im Abtauzyklus kurzzeitig steigen, dies beeinträchtigt die Lebensmittel im Schrank jedoch nicht. Die Abtau-LED leuchtet.

Einige der Lebensmittel sind gefroren:

- Zu viele Lebensmittel verstaut – Luftein-/auslass blockiert.
- Temperatursollwert zu niedrig.
- Verdampferlüfter ist möglicherweise defekt.

Kondenswasser um die Tür:

- Umgebungsluftfeuchtigkeit zu hoch.
- Tür nicht dicht verschlossen.
- Beschädigte Türdichtung.
- Parameter bezüglich der Türrahmenheizung wurde nicht korrekt eingestellt.

Zu hoher Energieverbrauch:

- Raumtemperatur zu hoch.
- Die Tür wird zu oft und/oder zu lange geöffnet.
- Die Tür wird offen gelassen.
- Beschädigte Türdichtung.
- Temperatursollwert zu niedrig.
- Zu viele Lebensmittel verstaut – Luftein-/auslass blockiert.
- Warme oder heiße Speisen in Produkt eingebracht.
- Das Produkt wurde in direktem Sonnenlicht oder in der Nähe von wärmeabgebenden Oberflächen aufgestellt.
- Standardeinstellungen wurden geändert.

Tauwasser

Während des Abtauens produziert das Produkt Wasser, das durch ein Vakuumpartikel an der Oberseite des Schrankes in das Rückverdampfungssystem geleitet wird (bei Premier-Schränken)

Das Wasser wird mit einem elektrischen Heizelement und einem Ventilatormotor rückverdampft. In seltenen Fällen entsteht durch das Nutzungsverhalten des Schrankes mehr Wasser, als das Produkt rückverdampfen kann, sodass es zu einem Wasserüberlauf kommen kann. Wenn dies geschieht, kann das elektrische Heizelement auf 100 % umgestellt werden. Alternativ kann es abgeschaltet werden und stattdessen die Wasserleitung auf der Rückseite an einen Abfluss angeschlossen werden. Diese Änderungen müssen von einem qualifizierten Servicetechniker durchgeführt werden.

Türschließmechanismus

Die Tür ist mit einem Selbstschließsystem ausgestattet. Wenn die Tür um weniger als 90° geöffnet wird, schließt sie sich von selbst. Wenn die Tür um mehr als 90° geöffnet wird, bleibt sie offen.

Die Tür kann mit dem Fußpedal geöffnet werden. So bleiben beide Hände frei, wenn Lebensmittel in den Schrank gestellt werden.

Stromausfall

Bei einem Stromausfall speichert die Steuerung die Temperatureinstellung und startet das Produkt nach Wiederherstellung der Stromversorgung neu.

Reinigung

Eine unzureichende Reinigung führt dazu, dass das Produkt nicht mit optimaler Leistung läuft oder letztlich einen Defekt erleidet.



Vor dem Reinigen sollte das Produkt immer von der Stromversorgung getrennt werden.



Spülen Sie das Produkt nicht mit Wasser, verwenden Sie keinen Wasserstrahl oder Dampfschlauch, da dies zu Kurzschlüssen in der Elektrik führen kann.



Reinigungsmittel, die Chlor oder Chlorverbindungen sowie andere korrosive Mittel enthalten, **dürfen nicht verwendet werden**, da sie Korrosion an den Edelstahlblenden des Schrankes und des Verdampfers verursachen können.



Das Produkt muss frei von Staub und Schmutz gehalten werden. Dafür eignen sich am besten ein Staubsauger und eine Bürste.



Für die Außenpflege Edelstahlpolitur verwenden.



Das Produkt ist in geeigneten Intervallen innen mit einer milden Seifenlösung zu reinigen und gründlich zu überprüfen, bevor es wieder in Betrieb genommen wird.

Türdichtungen

In diesem Kapitel geht es um die Bedeutung einer gut funktionierenden Türdichtung.

Dichtungen sind ein wichtiger Teil eines Kühl-/Gefrierschranks. Dichtungen mit reduzierter Funktionalität beeinträchtigen die Dichtigkeit des Schrankes. Eine geringere Dichtigkeit kann zu erhöhter Luftfeuchtigkeit, interner Vereisung, einem vereisten Verdampfer (was zu einer verringerten Kälteleistung führt) und im schlimmsten Fall zu einer verkürzten Lebensdauer des Schrankes führen.



Daher ist es wichtig, den Zustand der Dichtung zu kennen. Eine regelmäßige Inspektion wird empfohlen.

Die Dichtung sollte regelmäßig mit einer milden Seifenlösung gereinigt werden. Wenn eine Dichtung ausgetauscht werden muss, wenden Sie sich an Ihren Lieferanten.

Langzeitlagerung

Wenn das Produkt außer Betrieb genommen wird und für eine langfristige Lagerung vorbereitet werden muss, reinigen Sie den Innenraum, die Tür und die Türdichtung gründlich mit einem feuchten Tuch mit warmem Seifenwasser. Eventuell vorhandene Lebensmittelreste könnten Schimmel erzeugen.

Service

Wenn die Kühlung ausfällt, prüfen Sie zunächst, ob das Gerät versehentlich an der Steckdose getrennt oder ausgeschaltet wurde oder ob eine Sicherung durchgebrannt ist.

Falls die Ursache für den Kühlausfall nicht gefunden werden kann, wenden Sie sich bitte an den Betrieb, der das Gerät installiert hat.

Bitte teilen Sie bei der Kontaktaufnahme mit HOSHIZAKI oder dem installierenden Betrieb den Namen und die Seriennummer im Inneren des Schrankes mit. Diese Daten sind auf dem Typenschild angegeben.

Technische Daten

Platzierung des Etiketts:

PRODUCT DESCRIPTION LABEL		
1 Product Number		PRODUCT NUMBER 1
2 Product Description		
3 Model		PRODUCT DESCRIPTION 2
4 Refrigerant (GWP)		MODEL 3
5 CO2 Equivalent		REFRIGERANT 4
6 IP Protection		CO2 EQUIVALENT 5
7 Climate Class		IP PROTECTION 6
8 Production Date		CLIMATE CLASS 7
9 Total power / Current / Lamp power		PRODUCTION DATE 8
10 Voltage - Frequency		TOTAL POWER / CURRENT / LAMP POWER 9
11 Heating Element		VOLTAGE - FREQUENCY 10
12 System Pressure		HEATING ELEMENT 11
13 Blowing Agent		SYSTEM PRESSURE 12
14 Serial Number		BLOWING AGENT 13
		S/N: 14 HOSHIZAKI EUROPE B.V. Burgemeester Stramanweg 101 1101 AA Amsterdam, The Netherlands

Trade mark			HOSHIZAKI			
Model name			PREMIER U 70	PREMIER U 140	PREMIER U 80	PREMIER U 60
Vorgesehene Verwendung			Storage	Storage	Storage	Storage
Kühltemperatur			X	X	X	X
Gefriertemperatur			X	X	X	X
Mehrzweckschrank						
Vertikaler Schrank			X	X	X	X
Thekenschrack						
Parameter	Symbol	Unit				
Gesamtvolumen	VnT	L	700	1400	700	480
Klimaklasse			CC5	CC5	CC5	CC5
Versorgungsspannung/Frequenz	V / Hz		230 - 50	230 - 50	230 - 50	230 - 50
Kältemittel (CO2-Schrank)			CO2	CO2	CO2	CO2
Kältemittel (RU-1-Schrank)			HFC / HFO Refrigerant*	HFC / HFO Refrigerant*	HFC / HFO Refrigerant*	HFC / HFO Refrigerant*
Kontaktangaben:	HOSHIZAKI EUROPE B.V. Address: Burgemeester Stramanweg 101 1101 AA Amsterdam, The Netherlands Tel: +31 (0)20 691 84 99 - http://hoshizaki.europe.com/					

* Kühlmittel, die mit der Düse kompatibel sind (R449A, R448A, R45A usw. Bitte überprüfen Sie das Datenblatt der verwendeten Düse)

HOSHIZAKI

Premier Remote Cabinets



Trade mark			HOSHIZAKI		
Model name			BAKER U 950	BAKER GA 950	PREMIER SF 950
Vorgesehene Verwendung			Storage	Cooling /Freezing / Storage / Proving	Cooling / Shock Freezing
Kühltemperatur			X	X	X
Gefriertemperatur			X	X	X
Mehrzweckschrank				X	X
Vertikaler Schrank			X	X	X
Thekensschrank					
Parameter	Symbol	Unit			
Gesamtvolumen	VnT	L	1000	950	950
Klimaklasse			CC5	CC5	CC5
Versorgungsspannung/Frequenz	V / Hz		230 - 50	230 – 50	230 – 50
Kältemittel (RU-1-Schrank)			HFC / HFO Refrigerant*	HFC / HFO Refrigerant*	HFC / HFO Refrigerant*
Contact	HOSHIZAKI EUROPE B.V. Address: Burgemeester Stramanweg 101 1101 AA Amsterdam, The Netherlands Tel: +31 (0)20 691 84 99 - http://hoshizaki.europe.com/				

* Kühlmittel, die mit der Düse kompatibel sind (R449A, R448A, R45A usw. Bitte überprüfen Sie das Datenblatt der verwendeten Düse)

HOSHIZAKI

Premier Remote Cabinets



Abmessungen

PREMIER U 70

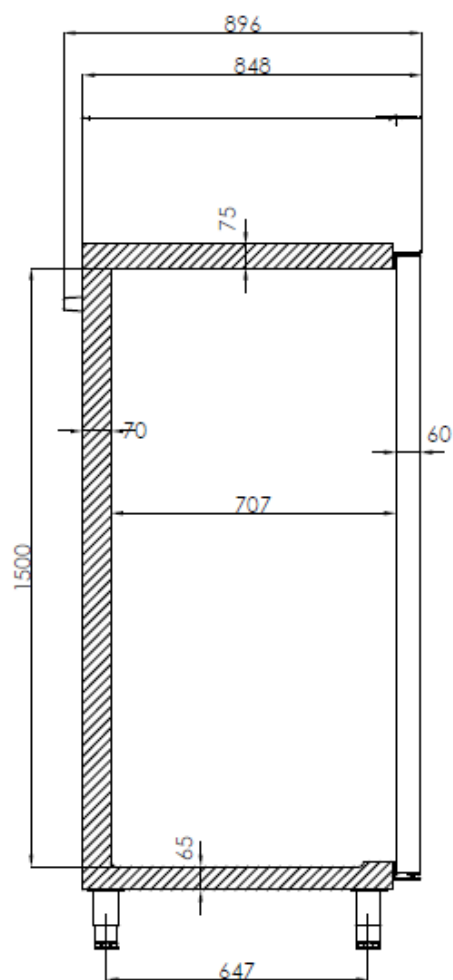
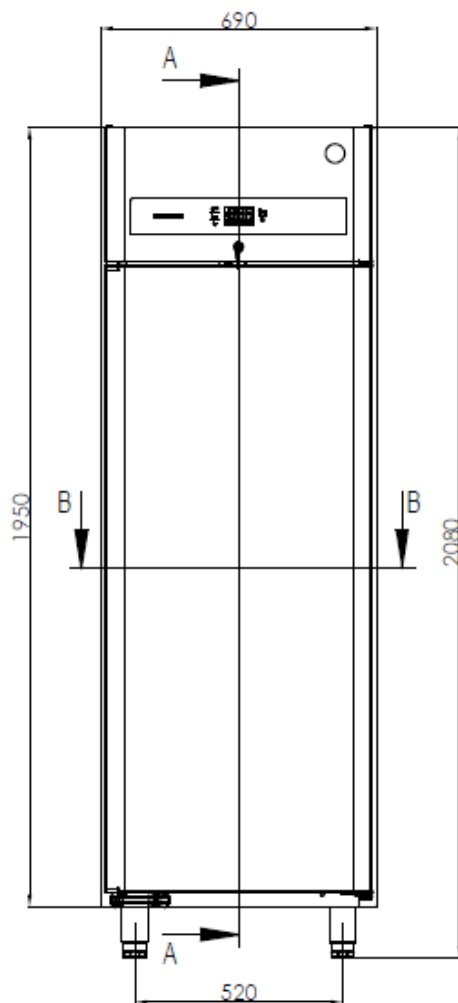

A-A

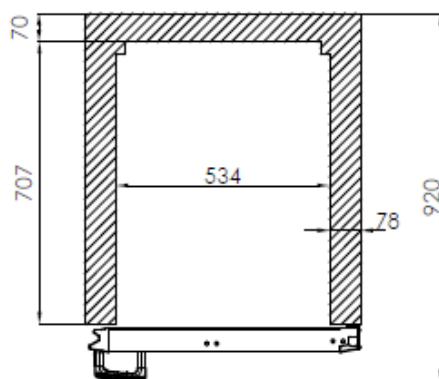

B-B

HOSHIZAKI

Premier Remote Cabinets



PREMIER U 60

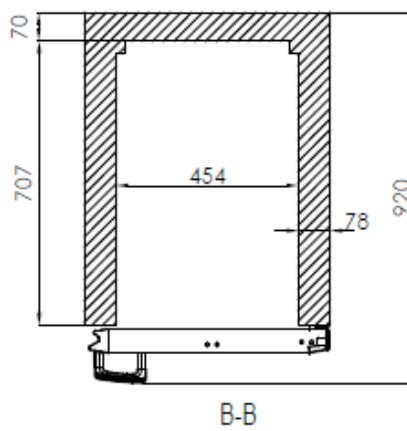
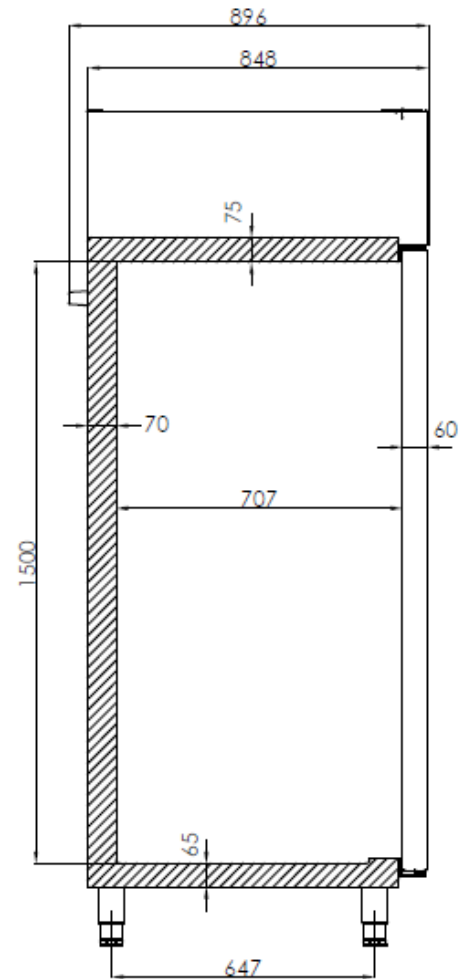
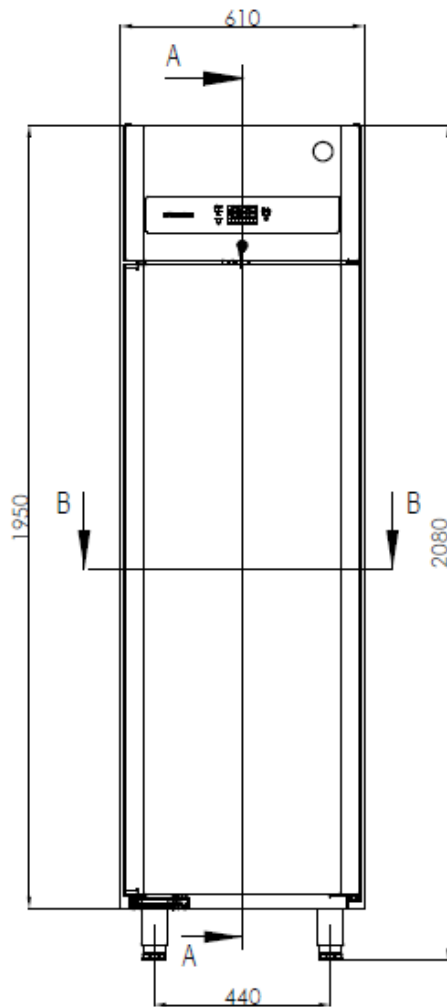

HOSHIZAKI

Premier Remote Cabinets



PREMIER U 80

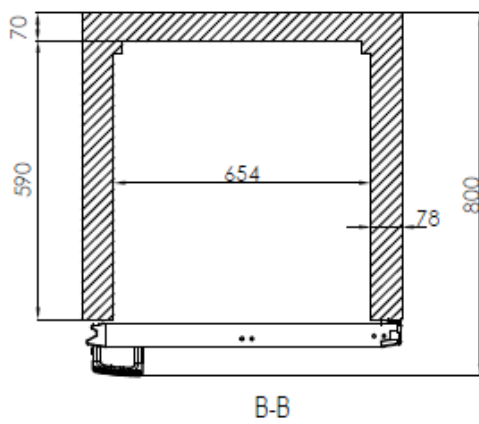
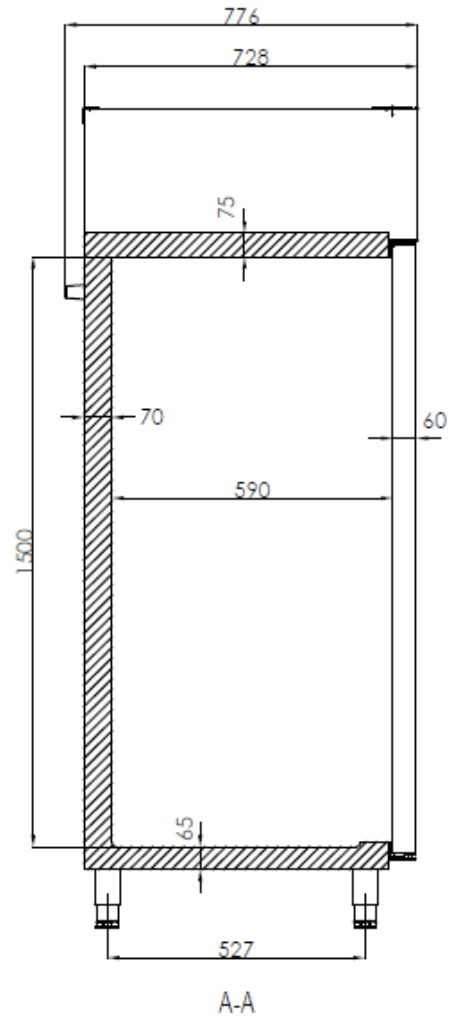
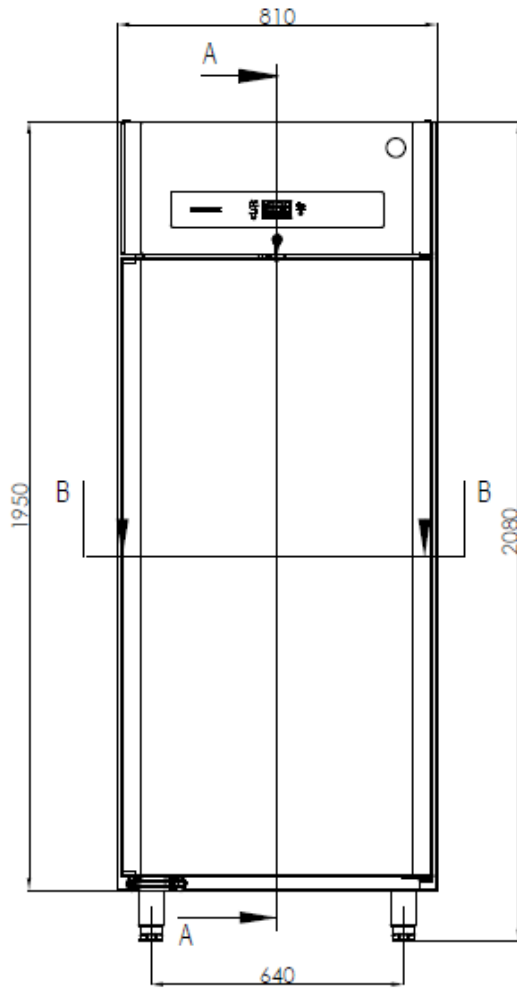

HOSHIZAKI

Premier Remote Cabinets



PREMIER U 140

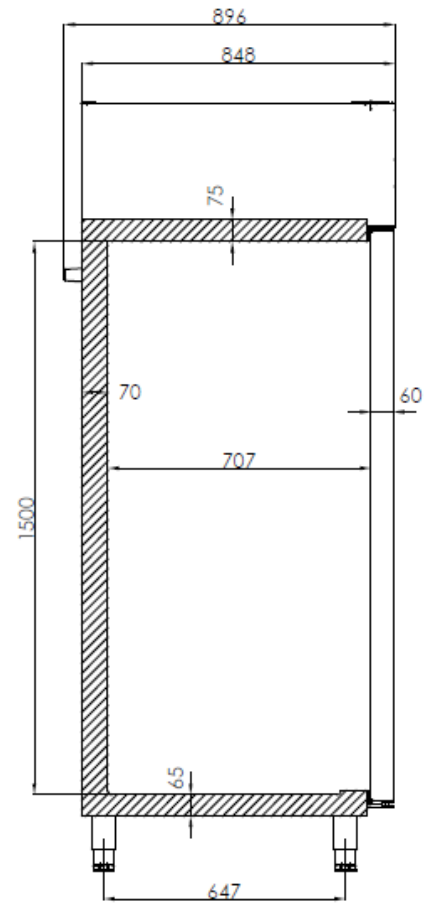
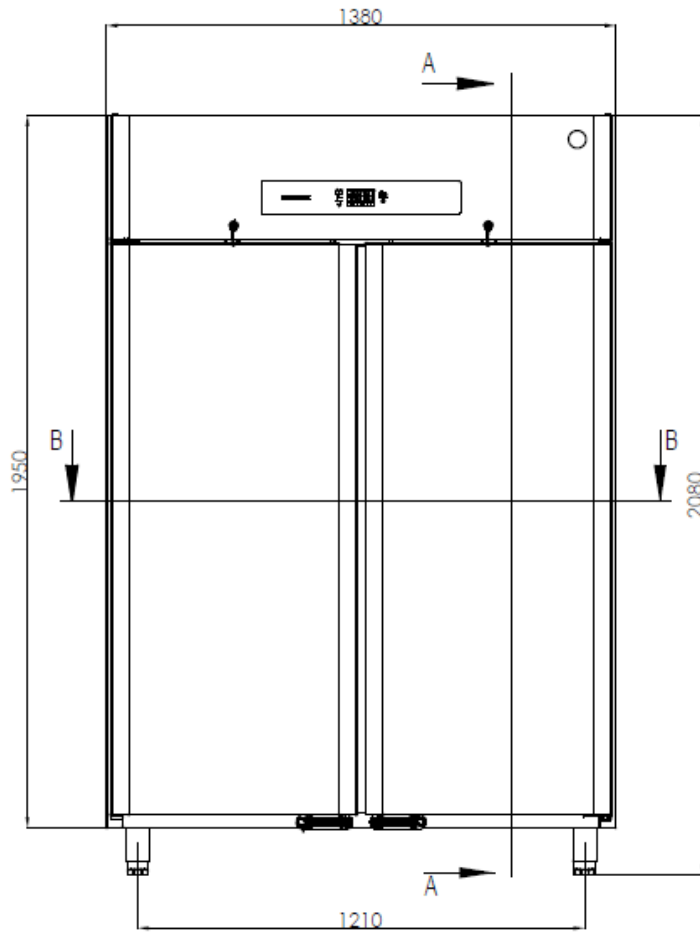

A-A

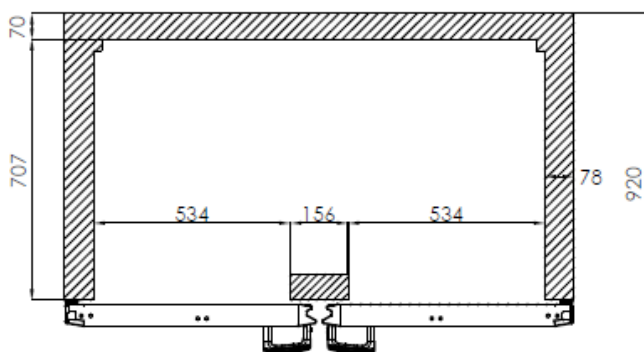

B-B

HOSHIZAKI

Premier Remote Cabinets



BAKER U 950

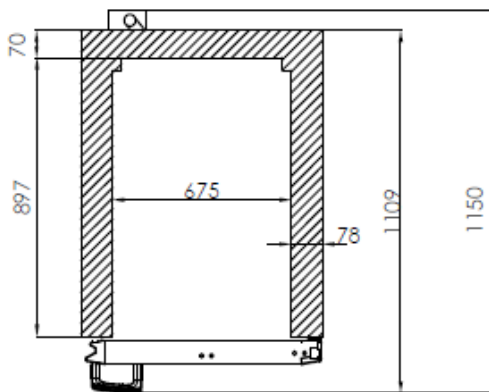
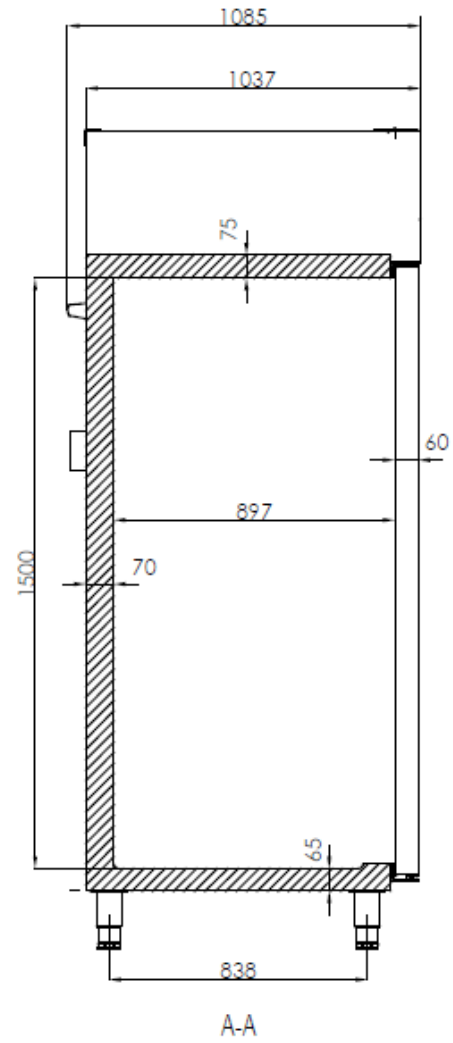
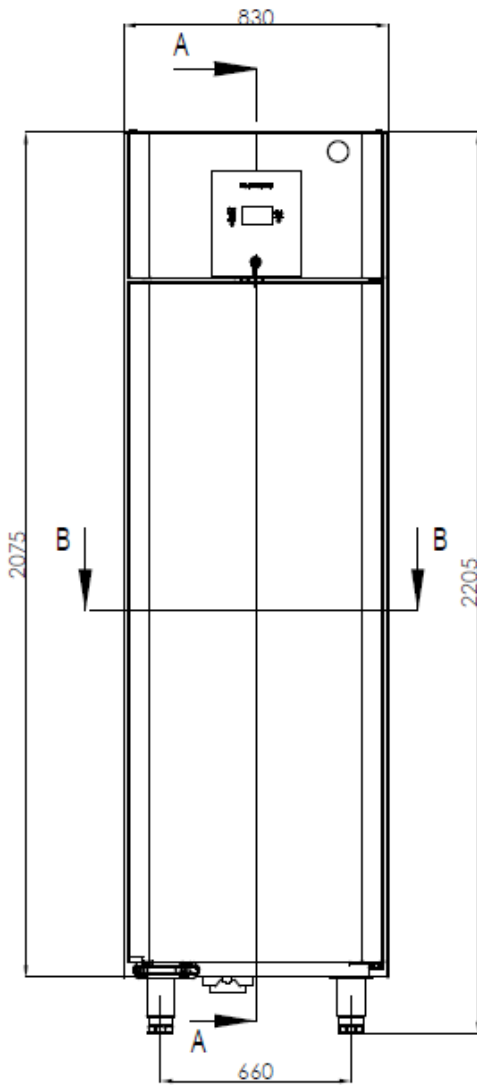

HOSHIZAKI

Premier Remote Cabinets



BAKER GA 950 (RU1)

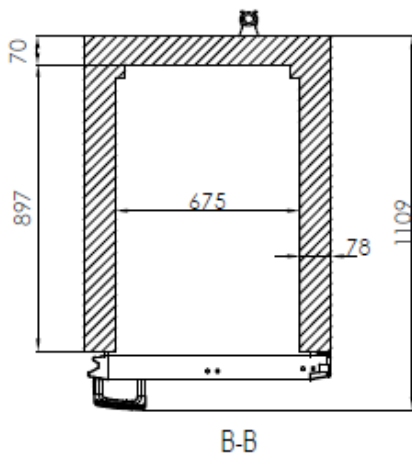
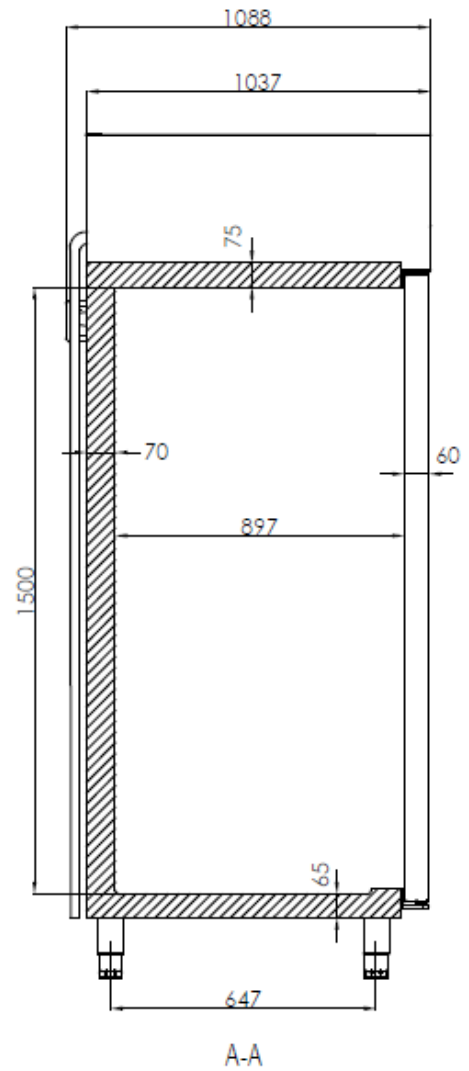
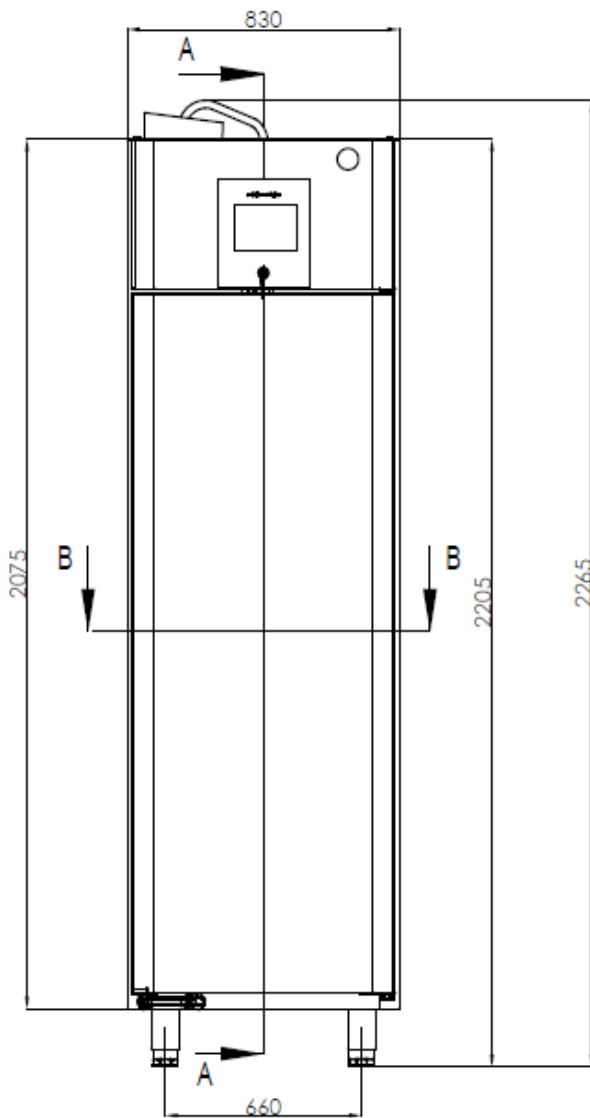

HOSHIZAKI

Premier Remote Cabinets



BAKER SF 950 (RU1)

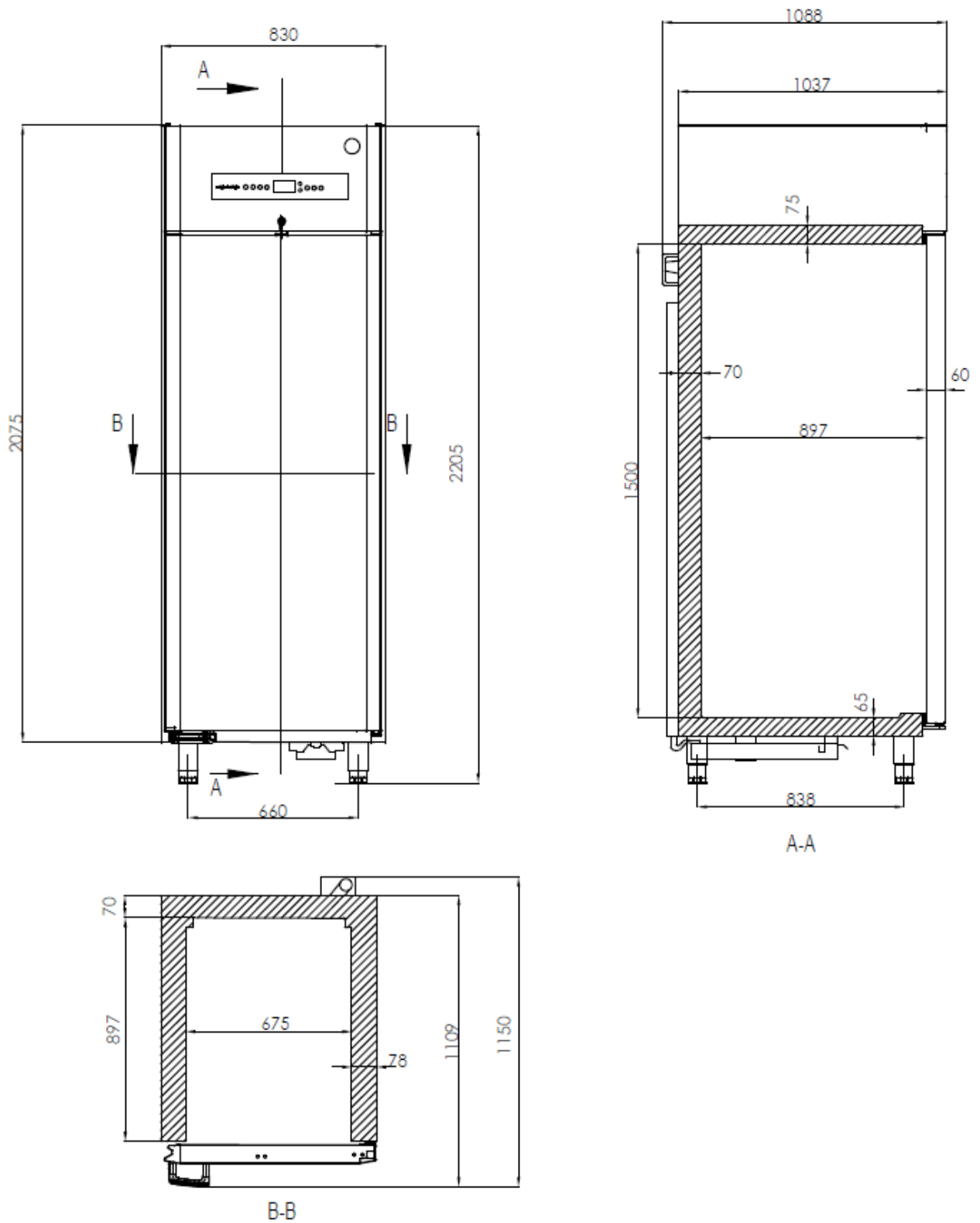

Entsorgung

Nachstehendes gilt nur für Großbritannien.

Die Entsorgung eines alten Schrankes wird nur angeboten, wenn wir gleichzeitig einen neuen ausliefern. Die Schränke müssen vor der Abholung vollständig abgetaut und entleert werden.

Hoshizaki erkennt an, dass unsere Produkte für den Catering-Markt als Elektro- und Elektronik-Altgeräte gelten, wenn sie veraltet sind. Um sicherzustellen, dass Hoshizakis Verantwortlichkeiten korrekt und umweltfreundlich gehandhabt werden, beteiligen wir uns am größten Business-to-Business-Compliance-Programm in Großbritannien – B2B Compliance <http://www.b2bcompliance.org.uk>

B2B Compliance wird in unserem Namen alle Aspekte unserer Verantwortung bei der Sammlung und Entsorgung von Geräten abdecken, die unter die britischen Vorschriften zu Elektro- und Elektronik-Altgeräten fallen. B2B Compliance kann unter der Telefonnummer 01691 676124 kontaktiert werden.

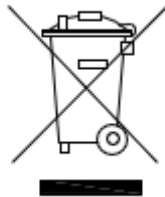

HOSHIZAKI

Premier Remote Cabinets



Schaltpläne

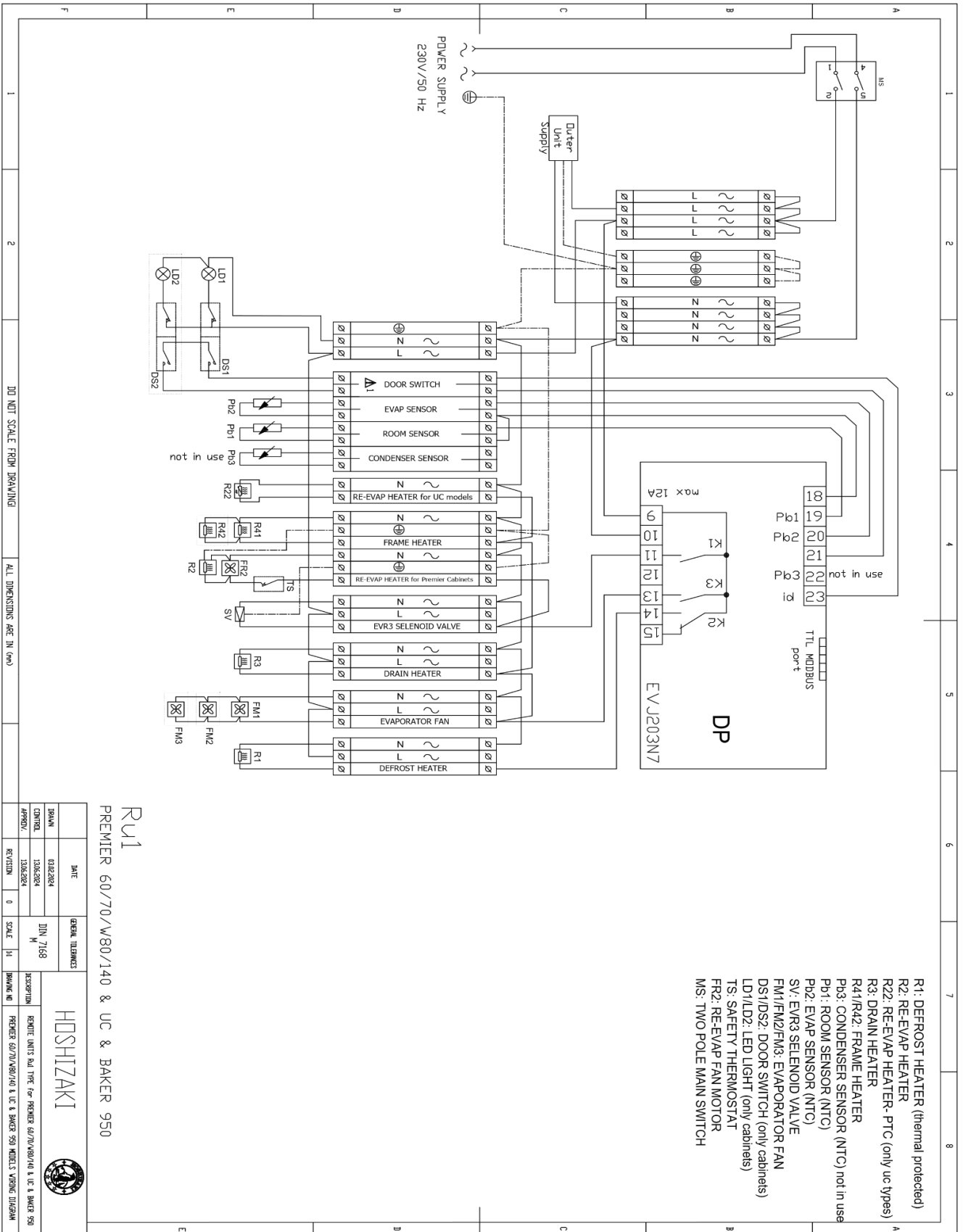

RU1
PREMIER 60/70/W/80/140 & UC & BAKER 950

DATE	GENERAL DIMENSIONS	HOSHIZAKI 
DRAWN	DIN 7168	
CONTROL	M	
REVISION	SCALE	DESCRIPTION
0	1:1	REMOTE UNITS RA1 TYPE FOR PREMIER 60/70/W/80/140 & UC & BAKER 950
		PREMIER 60/70/W/80/140 & UC & BAKER 950 MODEL'S VARIANTE DIMENSION

HOSHIZAKI

Premier Remote Cabinets

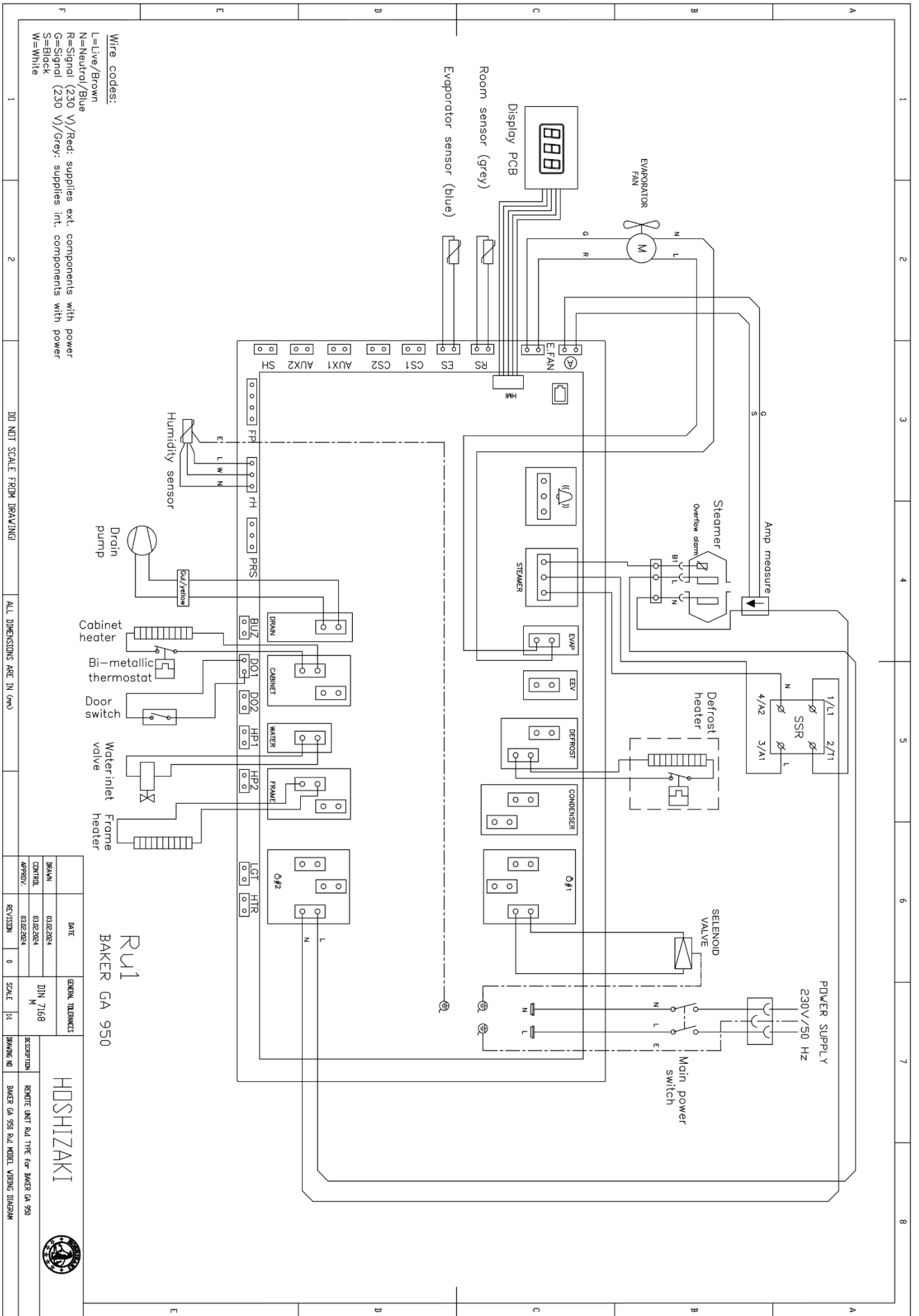

DATE		GENERAL DIMENSIONS		HOSHIZAKI	
BRAN.	03/23/2024	DIN 7168			
CONTROL	03/23/2024	M			
APPROV.	03/23/2024	SCALE	1:1		
REVISION	0	DESCRIPTION		REMOTE UNIT RU1 TYPE FOR BAKER GA 950	
		DRAWING NO.		BAKER GA 950 RU1 MODEL WIRING DIAGRAM	

HOSHIZAKI

Premier Remote Cabinets

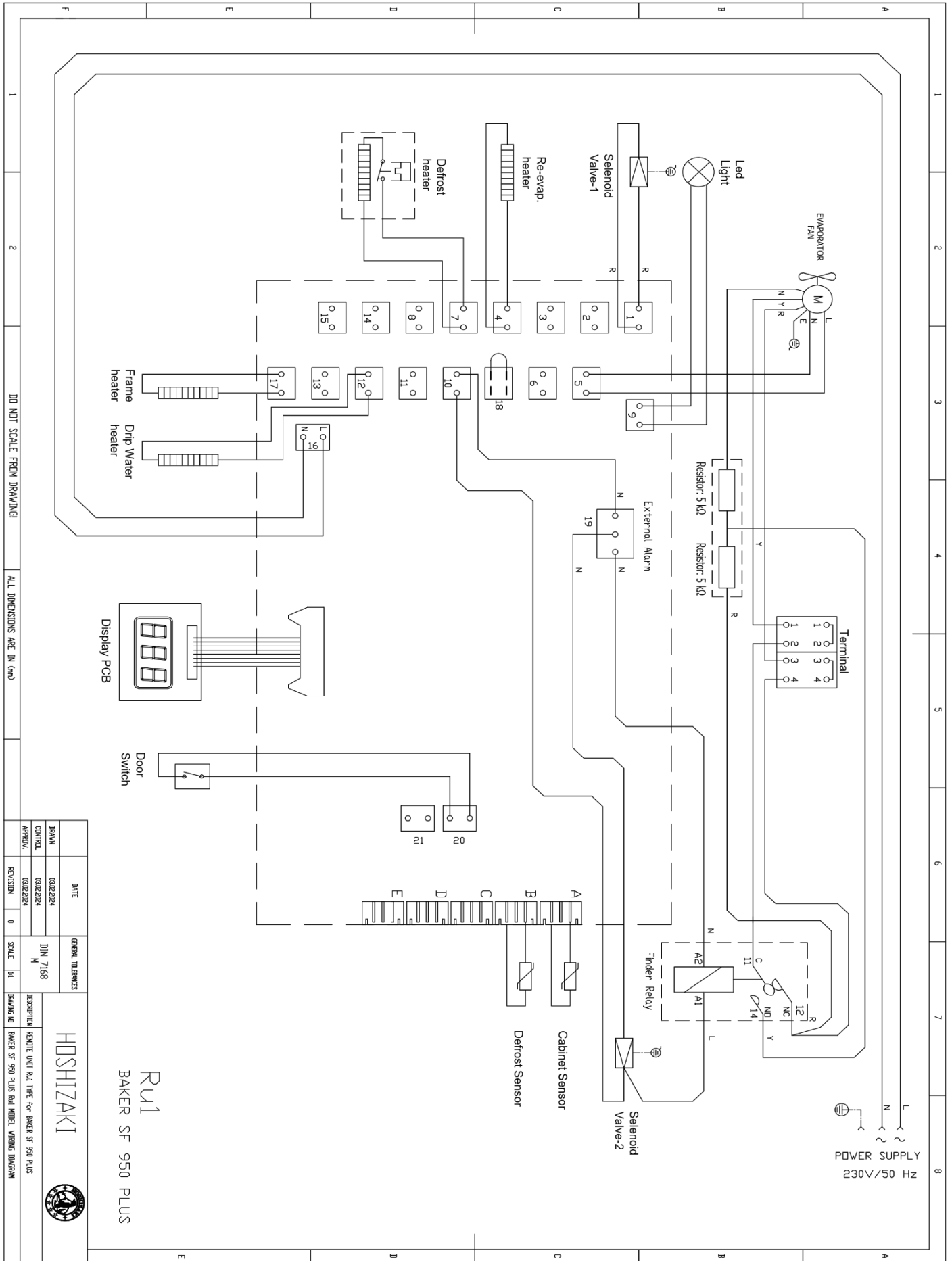

DO NOT SCALE FROM DRAWING

ALL DIMENSIONS ARE IN (mm)

GENERAL DIMENSIONS		DATE	
DRAWN	03/23/2014	DATE	03/23/2014
CONTROL	03/23/2014	REVISION	0
APPROV.	03/23/2014	SCALE	1:1

RECEPTION		DRAWING NO.	
UNIT	BAKER SF 950 PLUS	BAKER SF 950 PLUS	BAKER SF 950 PLUS
RAIL TYPE	BAKER SF 950 PLUS	BAKER SF 950 PLUS	BAKER SF 950 PLUS
RAIL MODEL	BAKER SF 950 PLUS	BAKER SF 950 PLUS	BAKER SF 950 PLUS
VERSION	BAKER SF 950 PLUS	BAKER SF 950 PLUS	BAKER SF 950 PLUS

HOSHIZAKI



HOSHIZAKI Premier Remote Cabinets

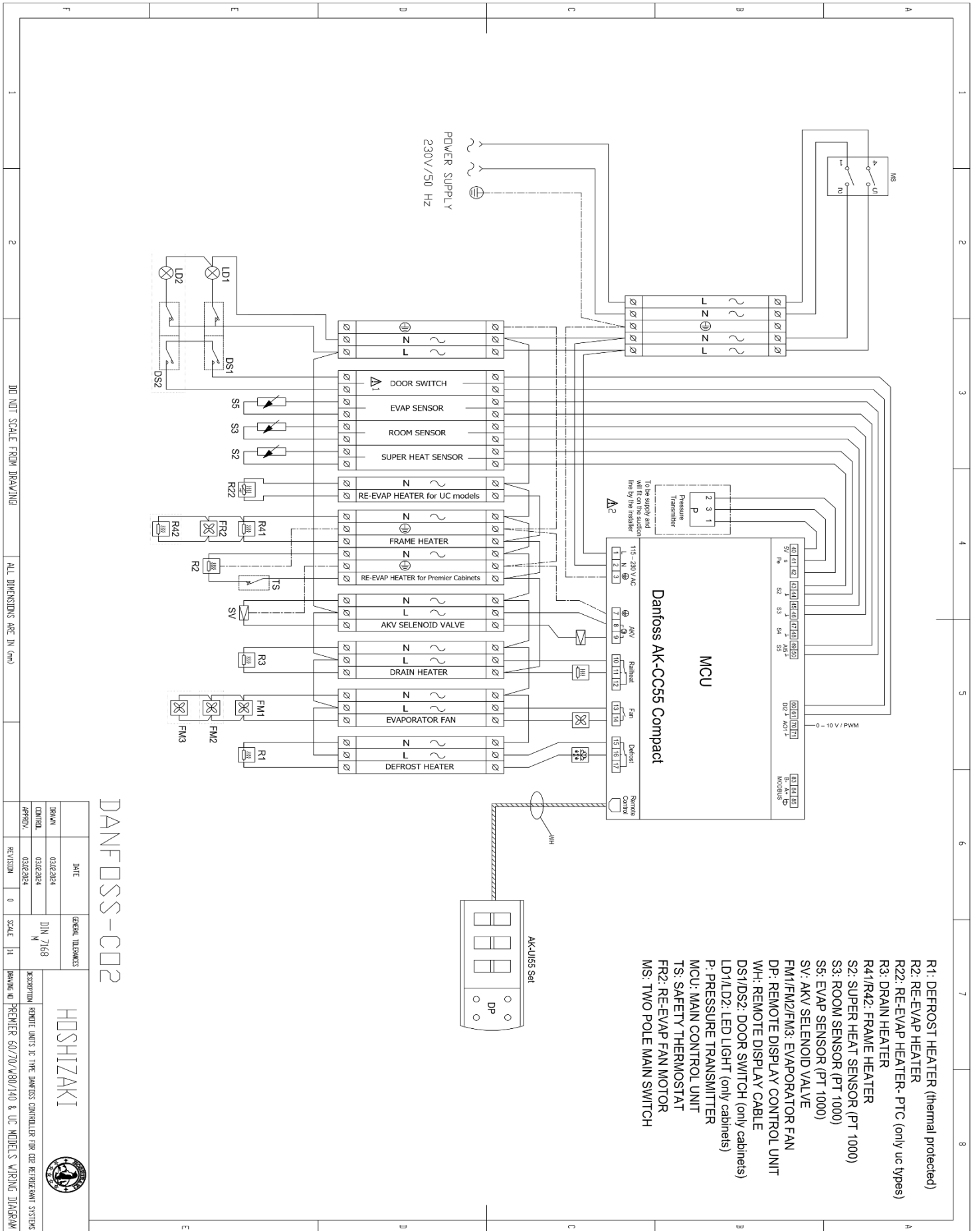

- R1: DEFROST HEATER (thermal protected)
- R2: RE-EVAP HEATER
- R22: RE-EVAP HEATER- PTC (only uc types)
- R3: DRAIN HEATER
- R41/R42: FRAME HEATER
- S2: SUPER HEAT SENSOR (PT 1000)
- S3: ROOM SENSOR (PT 1000)
- S5: EVAP SENSOR (PT 1000)
- SV: AKV SELENOID VALVE
- FM1/FM2/FM3: EVAPORATOR FAN
- DP: REMOTE DISPLAY CONTROL UNIT
- DS1/DS2: DOOR SWITCH (only cabinets)
- W/H: REMOTE DISPLAY CABLE
- P: PRESSURE TRANSMITTER
- MCU: MAIN CONTROL UNIT
- TS: SAFETY THERMOSTAT
- FR2: RE-EVAP FAN MOTOR
- MS: TWO POLE MAIN SWITCH

DANFOSS-CC2

DATE	03.02.2024	GENERAL TOLERANCES	DIN 7168
DRAWN	03.02.2024		
CONTROL	03.02.2024		
APPROV.	03.02.2024		
REVISION	0	SCALE	1:1

DESCRIPTION: REMOTE UNITS TO THE DANFOSS CONTROLLER FOR CO2 REFRIGERANT SYSTEMS
 DRAWING NO: PREMIER 60/70/80/140 & UC MODELS WIRING DIAGRAM



HOSHIZAKI Premier Remote Cabinets

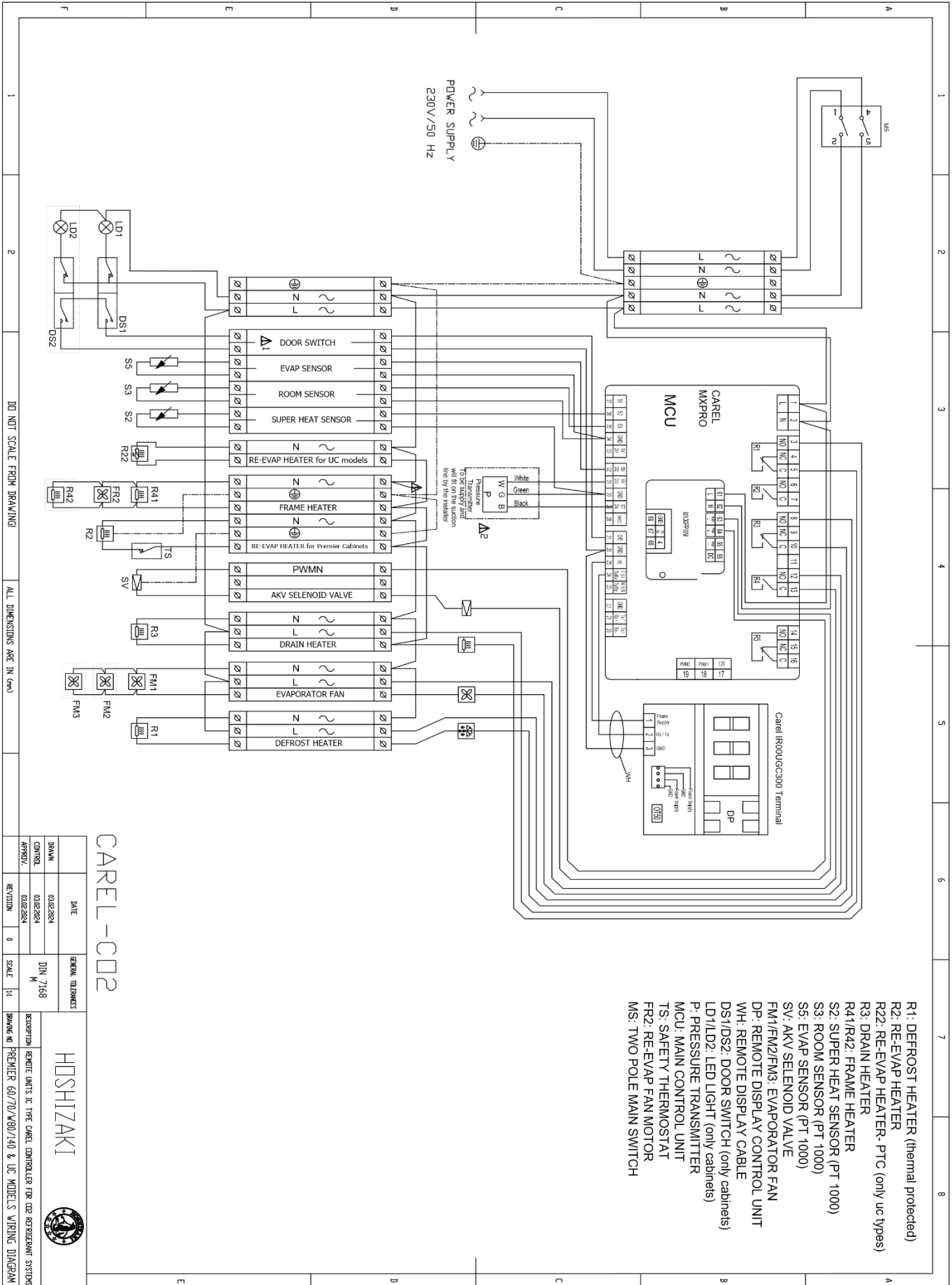

- R1: DEFROST HEATER (thermal protected)
- R2: RE-EVAP HEATER
- R22: RE-EVAP HEATER - PTC (only uc types)
- R3: DRAIN HEATER
- R41/R42: FRAME HEATER
- S2: SUPER HEAT SENSOR (PT 1000)
- S3: ROOM SENSOR (PT 1000)
- S5: EVAP SENSOR (PT 1000)
- SV: AKV SELENOID VALVE
- FM1/FM2/FM3: EVAPORATOR FAN
- DP: REMOTE DISPLAY CONTROL UNIT
- WH: REMOTE DISPLAY CABLE
- DS1/DS2: DOOR SWITCH (only cabinets)
- LD1/LD2: LED LIGHT (only cabinets)
- P: PRESSURE TRANSMITTER
- MCU: MAIN CONTROL UNIT
- TS: SAFETY THERMOSTAT
- FRZ: RE-EVAP FAN MOTOR
- MS: TWO POLE MAIN SWITCH

CAREL-CD2

DATE		GENERAL TOLERANCES	
DATE	02/02/2024	DIN	7168
BRANCH	02/02/2024	M	
CONTROL	02/02/2024	SCALE	1:1
APPROV.	02/02/2024	REVISION	0

DESCRIPTION: REMOTE UNITS IN TYPE CAREL CONTROLLER FOR CDR REFRIGERANT SYSTEMS
 DRAWING NO: PREMIER 60/70/W80/140 & UC MODELS WIRING DIAGRAM

DO NOT SCALE FROM DRAWING

ALL DIMENSIONS ARE IN (mm)

HOSHIZAKI

Premier Remote Cabinets

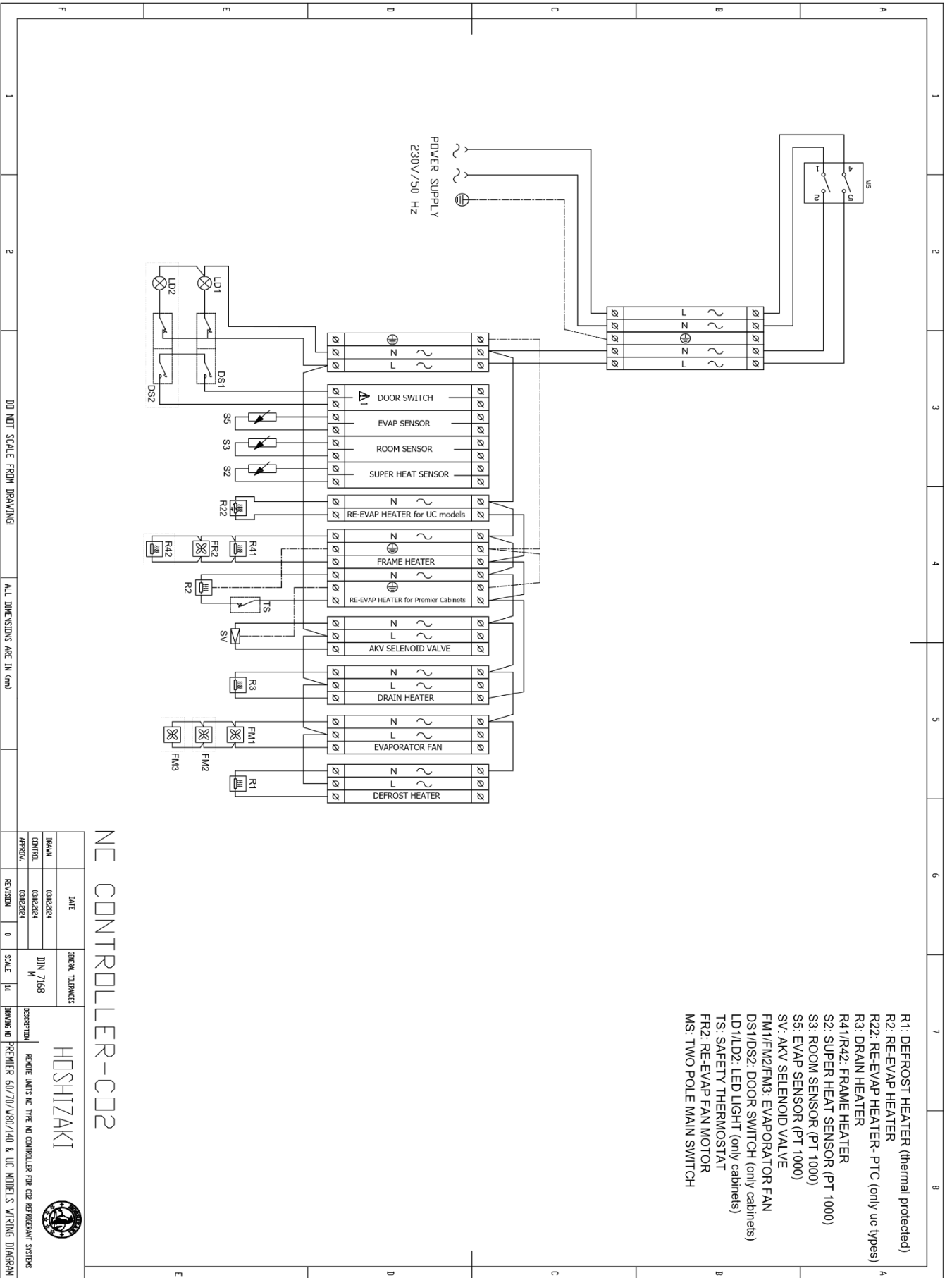

DO NOT SCALE FROM DRAWING
ALL DIMENSIONS ARE IN (mm)

ND CONTROLLER-C02

GENERAL INFORMATION		HOSHIZAKI	
DATE	03/02/2024	DESCRIPTION	REMOTE UNITS NE TYPE ND CONTROLLER FOR C02 REFRIGERANT SYSTEMS
DRAWN	03/02/2024	SCALE	1:1
CONTROL	03/02/2024	REVISION	0
APPROV.			





Kühlungsdiagramme

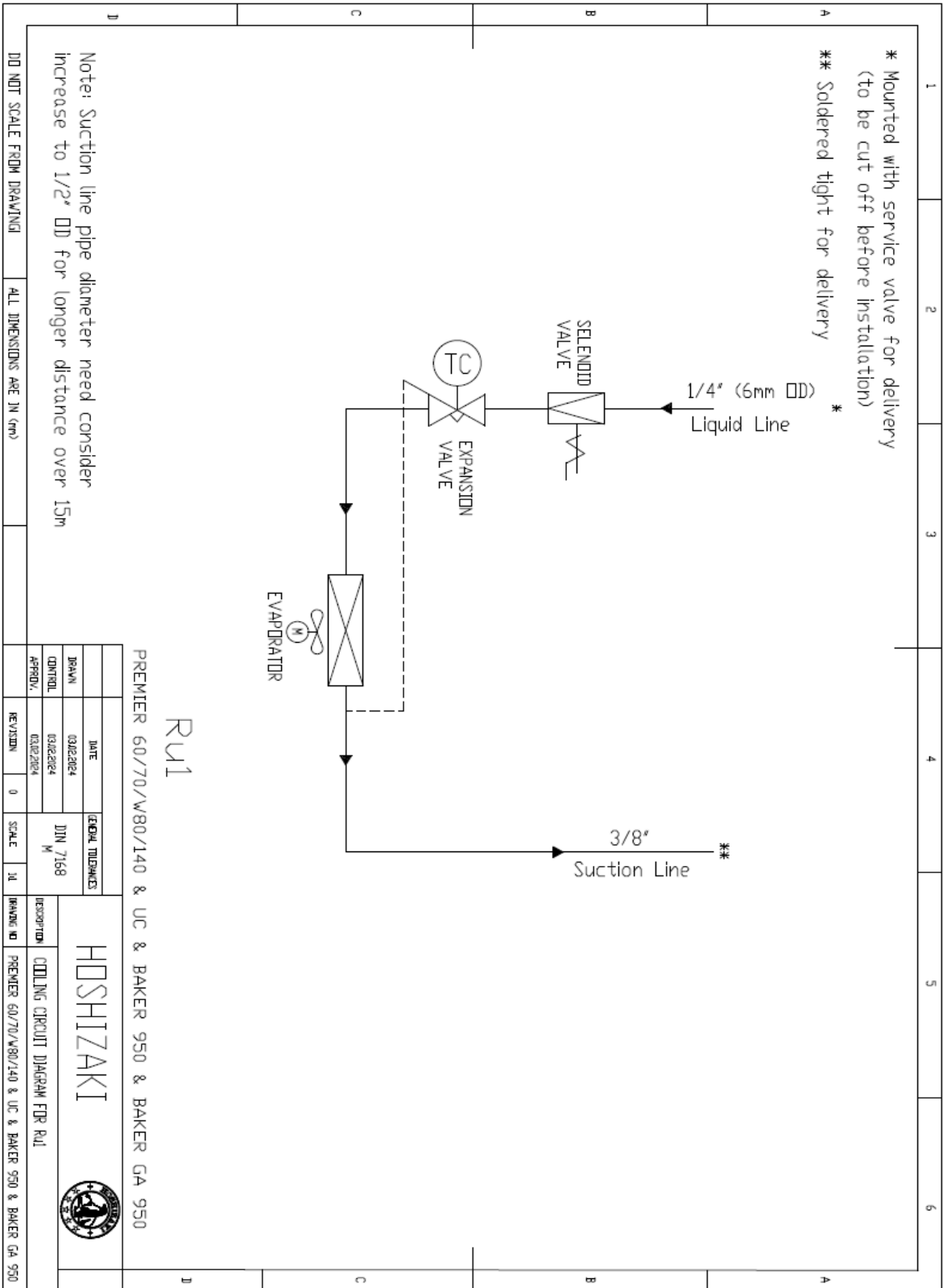

HOSHIZAKI

Premier Remote Cabinets

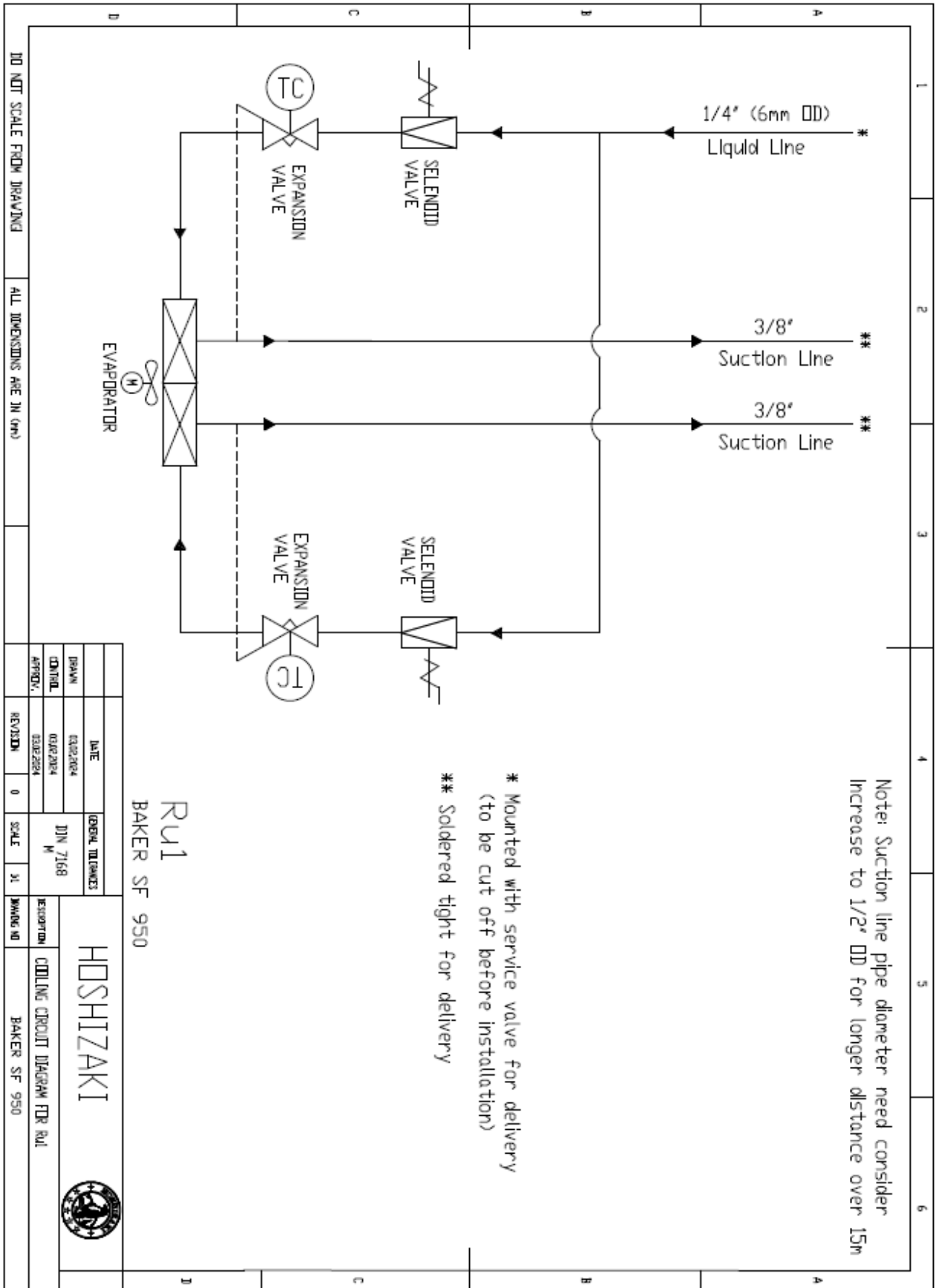

DATE		GENERAL TOLERANCES		REVISION		SCALE		DRAWING NO.	
DRAWN		DIN 7168		0		31		HOSHIZAKI	
CHECKED		M		0		31		HOSHIZAKI	
APPROV.		HOSHIZAKI		0		31		HOSHIZAKI	
REVISION		HOSHIZAKI		0		31		HOSHIZAKI	
0		HOSHIZAKI		0		31		HOSHIZAKI	
31		HOSHIZAKI		0		31		HOSHIZAKI	
31		HOSHIZAKI		0		31		HOSHIZAKI	
31		HOSHIZAKI		0		31		HOSHIZAKI	
31		HOSHIZAKI		0		31		HOSHIZAKI	

HOSHIZAKI

Premier Remote Cabinets

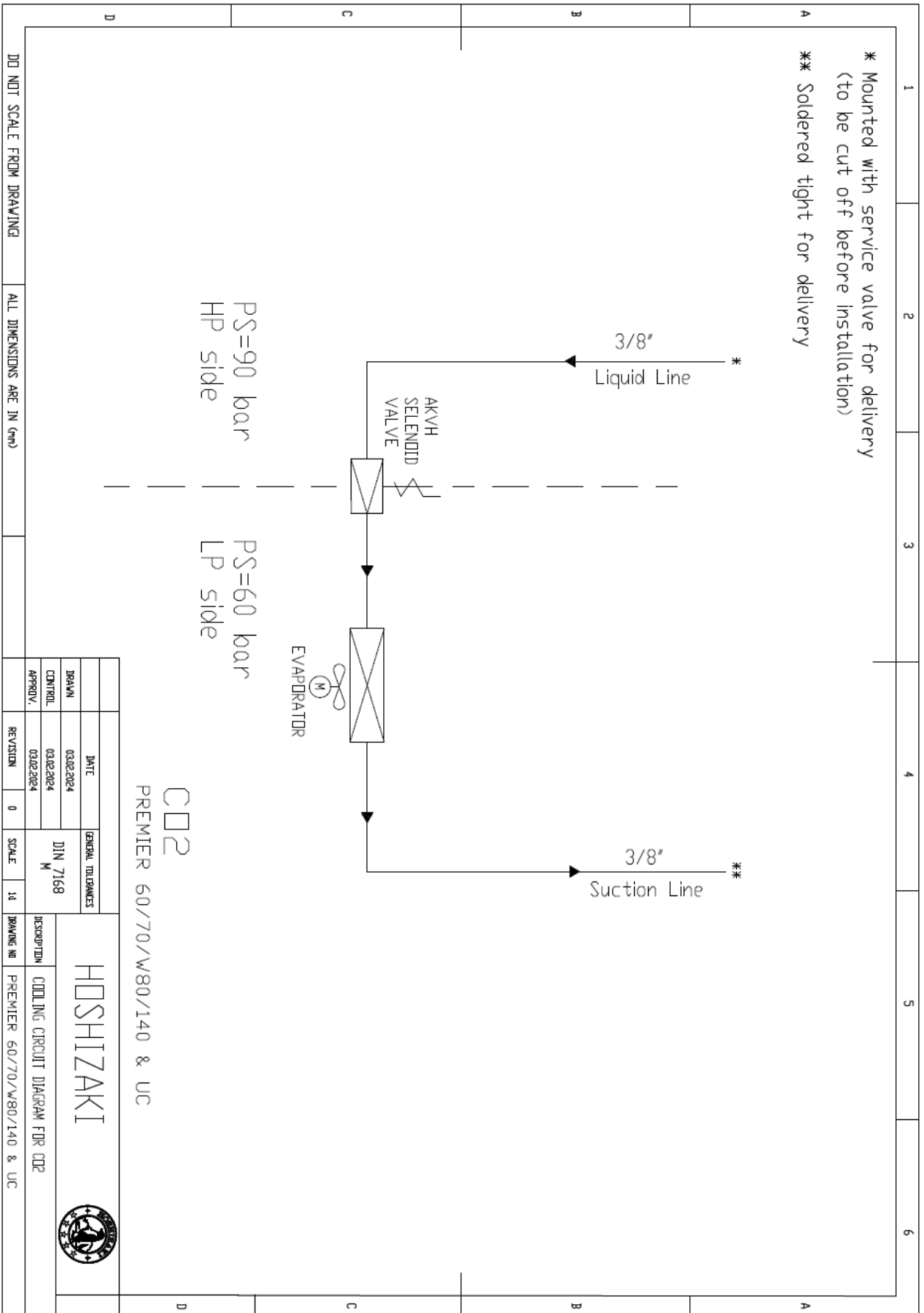

HOSHIZAKI

Premier Remote Cabinets



Alle Rechte vorbehalten

Hoshizaki behält sich das Recht der Änderung von Merkmalen und Informationen in dieser Anleitung vor.

Kontaktangaben

Hauptsitz

Hoshizaki Europe B.V.

TEL: +31 20 691

8499

Sales@hoshizaki.nl

<http://hoshizaki->

[europe.com/](http://hoshizaki-europe.com/)

Niederlassungen

Hoshizaki UK - Vereinigtes Königreich, Irland

TEL: +44 845 456 0585

uksales@hoshizaki.co.uk

Hoshizaki Deutschland - Deutschland, Schweiz, Österreich

TEL: +49 2154 92810, +49 5066 604612

info@hoshizaki.de

Hoshizaki BENELUX - Niederlande, Belgien, Luxemburg

TEL: +31 20 565 0420, +31 54 645 4252

sales@hoshizaki.nl

Hoshizaki France - Frankreich

TEL: +33 1 48 63 93 80

info@hoshizaki.fr

Hoshizaki Iberia - Spanien, Portugal

TEL: +34 93 478 09 52

info@hoshizaki.es

Hoshizaki Middle East - Naher Osten

TEL: +971 48 876 612

sales@hoshizaki.ae

Hoshizaki Danmark - Dänemark, Norwegen, Schweden

TEL: +45 8988 5350

salg@hoshizaki.dk

Hoshizaki Europe B.V – Alle anderen Länder in Europa und Afrika

TEL: +31 20 565 0420

sales@hoshizaki.nl

HOSHIZAKI

Premier Remote Cabinets



HOSHIZAKI

Premier Remote Cabinets



**MODELOS RU1 Y CO2 CON CONTROL A DISTANCIA
MANUAL DE OPERACIÓN, MANTENIMIENTO E INSTALACIÓN**



Datos de contacto:

HOSHIZAKI EUROPE B.V.

Dirección: Burgemeester Stramanweg 101 1101 AA Ámsterdam, Países Bajos

Tel.: +31 (0)20 691 84 99 - <http://hoshizaki-europe.com/>





Contenido

Aplicación	129
Información de seguridad	130
Ubicación.....	131
Conexión eléctrica	133
Uso general	134
Funcionamiento del producto (controlador Evco – modelo RU1)	135
Funcionamiento del producto (controlador Danfoss AK - CC55).....	136
Funcionamiento del producto (controlador Carel MPXpro).....	139
Funcionamiento del producto (sin controlador – modelo NC).....	145
Resolución de problemas	145
Agua de descongelación	146
Mecanismo de cierre de la puerta	146
Fallo de alimentación.....	146
Limpieza	146
Juntas de puerta.....	147
Almacenamiento a largo plazo	147
Mantenimiento	147
Datos técnicos	148
Dimensiones.....	150
Desecho	157
Diagramas de cableado eléctrico	158
Diagramas de refrigeración	164

HOSHIZAKI

Premier Remote Cabinets



Gracias por elegir un producto de calidad de Hoshizaki.

En este manual le indicamos cómo instalar, utilizar y mantener su nuevo producto.

Antes de salir de fábrica, nuestros productos son sometidos a una prueba completa de funcionamiento y calidad. Si, a pesar de todo, tiene problemas con el producto, póngase en contacto con su distribuidor local.

Las filiales y los distribuidores de Hoshizaki están a su disposición para ayudarle en todo el mundo.

Los productos fabricados por Hoshizaki están cubiertos por diferentes términos de garantía dependiendo del país en el que se vende el producto. Esta garantía está sujeta al uso correcto de acuerdo con las especificaciones, en las que, por ejemplo, el mantenimiento ordinario y las reparaciones eventuales son llevadas a cabo por técnicos designados por el distribuidor que tienen un conocimiento general del producto.

Los cambios en la instalación y otros usos del producto distintos de los especificados en este manual podrían afectar al funcionamiento y la durabilidad del producto.

El manual está redactado de acuerdo con nuestros conocimientos técnicos actuales. Trabajamos constantemente en la actualización de esta información y nos reservamos el derecho a realizar cambios técnicos.

Aplicación

El producto está destinado al almacenamiento de productos alimenticios en entornos no domésticos.

Está diseñado para el almacenamiento a temperatura constante y no puede utilizarse para enfriar alimentos calientes ni congelar alimentos frescos.

Este producto solo debe utilizarse para los fines para los que ha sido expresamente diseñado. Cualquier otro uso podría provocar que los alimentos almacenados en el producto no se mantengan a la temperatura correcta o incluso dañar el producto.

Este producto no es adecuado para almacenar plasma sanguíneo, muestras de laboratorio, productos farmacéuticos o sustancias similares.

El fabricante no será responsable de ningún daño causado por un uso incorrecto, inadecuado o no razonable del producto.



Información de seguridad

Importante

Descripción de los símbolos que se utilizan en este manual.



Advertencia Pasar por alto estas instrucciones puede provocar accidentes con lesiones personales.



Importante Si no se observan estas instrucciones, el producto podría dañarse o romperse.

Tenga en cuenta que Hoshizaki ha tomado precauciones para garantizar la seguridad del producto.

Lea atentamente la siguiente información relativa a la seguridad.



Es importante que todas las personas que vayan a utilizar o instalar el producto tengan acceso a este manual.



Este equipo no está diseñado para uso por personas con capacidades físicas, sensoriales o mentales reducidas, o bien, que carecen de experiencia o conocimientos adecuados, a menos que la persona responsable de su seguridad les supervise o proporcione instrucciones acerca del uso del equipo.



Es necesario vigilar a los niños para que no jueguen con el equipo.



El equipo puede contener piezas con bordes afilados en el compartimento del compresor y en el compartimento interior.



El equipo no debe transportarse en un camión de carga, ya que existe el riesgo de perder el equilibrio y provocar daños personales.



No tire del cable de alimentación para desconectar el equipo ni para moverlo.



Ubicación

Cuando reciba el producto, compruebe que el material de embalaje no está dañado.

Si se ha producido algún daño en el material de embalaje, debe considerarse si el producto también puede haber sufrido daños. Si los daños son importantes, póngase en contacto con su distribuidor.



Para esta tarea se necesitan al menos 2 personas. La parte más pesada del producto es la parte superior. Tenga esto en cuenta al retirar el palé de transporte.



Debido al gran peso del producto, el suelo podría dañarse o rayarse al moverlo.



Una instalación correcta garantiza la máxima eficacia de funcionamiento.



El producto debe colocarse en un lugar seco y bien ventilado.



Para garantizar un funcionamiento eficaz, no debe colocarse bajo la luz solar directa ni contra superficies que emitan calor. El producto está diseñado para funcionar a una temperatura ambiente de entre +16 °C y +40 °C.



Evite colocar el producto en un entorno que contenga cloro/ácidos (piscina, etc.) debido al riesgo de corrosión.



El producto y algunas partes de su interior están provistas de una película protectora que debe retirarse antes de su uso.



Limpie el producto con una solución jabonosa suave antes de utilizarlo.

El lugar de instalación debe estar nivelado y horizontal.

En las versiones con patas, utilice las patas ajustables para asegurarse de que el producto esté nivelado y en posición vertical.

En las versiones con ruedas, los dispositivos de bloqueo de las dos ruedas delanteras deben estar activados cuando el producto esté colocado.

HOSHIZAKI

Premier Remote Cabinets



Debe haber siempre 500 mm de espacio libre por encima del producto, para permitir el servicio. El producto debe colocarse lo más cerca posible de la pared.

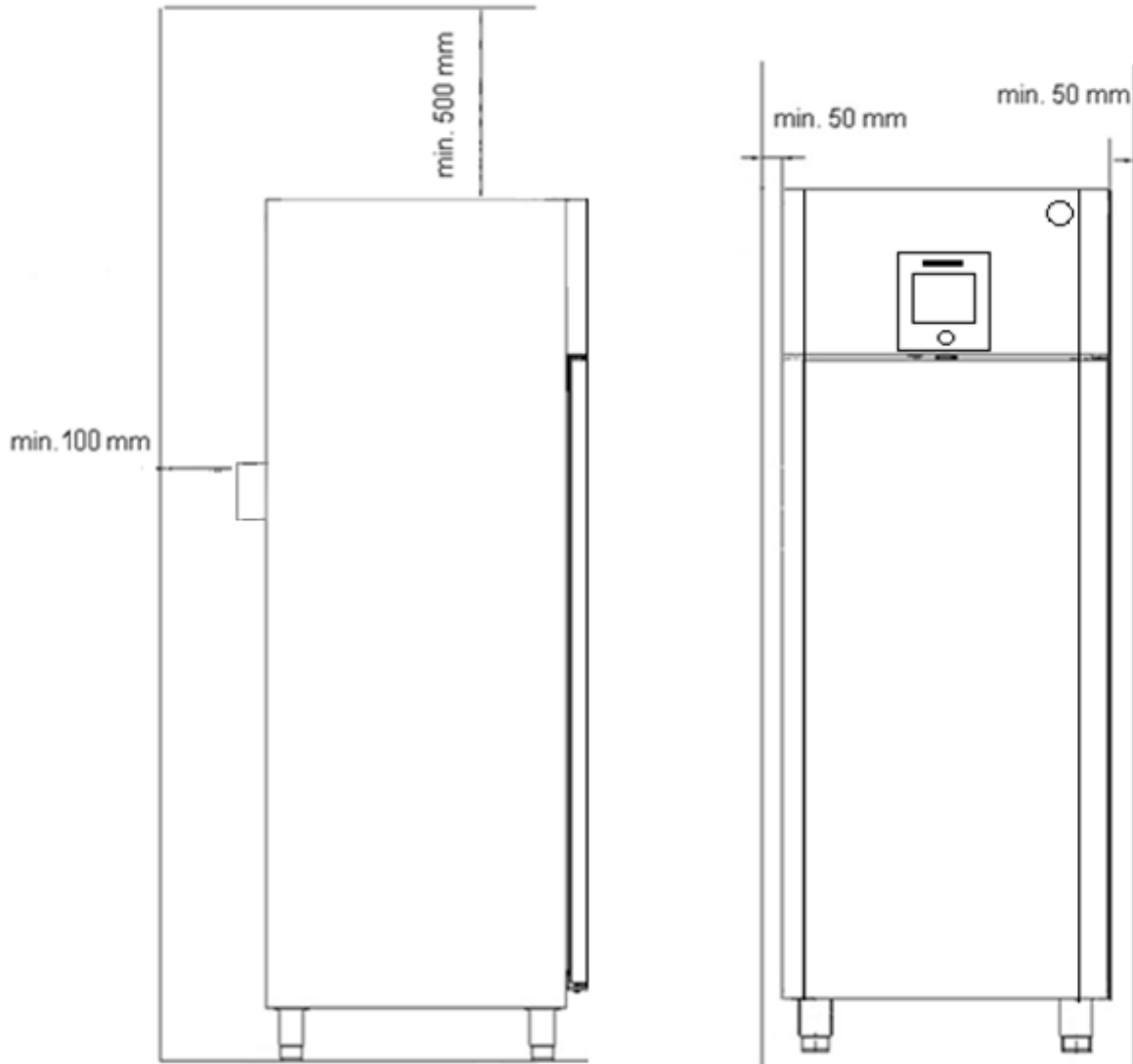



Conexión eléctrica

Antes de realizar la conexión eléctrica, lea detenidamente el texto siguiente.



El producto está previsto para la conexión a corriente alterna. La tensión de conexión (V) y la frecuencia (Hz) se indican en la placa de características que se encuentra en el armario.



No utilice nunca un cable alargador para este equipo!

Si la toma de corriente se encuentra a una distancia mayor que la longitud del cable de alimentación suministrado, póngase en contacto con un electricista para que instale una toma de corriente dentro del alcance del cable de alimentación.



Si el producto tiene algún defecto, **debe ser examinado por un técnico de servicio** cualificado que esté familiarizado con la unidad de control instalada y tenga experiencia en el mantenimiento del armario CO2.



En general, debe ser examinado por la empresa que haya conectado el producto.

Desconecte siempre la alimentación si se producen interrupciones en el suministro eléctrico, cuando se retiren/pongan piezas eléctricas y antes de limpiar y realizar el mantenimiento del producto.



No utilice el producto sin todas las piezas de protección instaladas para evitar tocar piezas de la máquina bajo tensión o en rotación.

Este producto no debe utilizarse al aire libre.



Deben cumplirse todos los requisitos de puesta a tierra prescritos por las autoridades eléctricas locales. El enchufe y la toma de corriente deben garantizar una correcta conexión a tierra. En caso necesario, consulte a un electricista.

Asegúrese de que el producto esté apagado en la toma de corriente o de que el enchufe del hervidor de agua esté desconectado antes de realizar tareas de mantenimiento en las piezas eléctricas. No basta con apagar el producto en el controlador.

Uso general



No dañe las piezas del sistema de refrigeración.



Si el producto está equipado con una bandeja de reevaporación debajo del armario, es importante no reparar/limpiar la bandeja ni el calefactor hasta que el armario haya estado apagado el tiempo suficiente para asegurarse de que el calefactor de reevaporación se haya enfriado, a fin de evitar el riesgo de quemaduras.



No utilice dispositivos eléctricos dentro del producto.



Para garantizar un flujo de aire adecuado en el armario, mantenga las zonas designadas libres de objetos.



Para evitar la corrosión innecesaria de las partes internas del armario, deben cubrirse todos los artículos que se almacenen en él, que no estén envueltos o embalados.



Si se modifica algún parámetro del controlador con respecto a los valores predeterminados, podría provocar que el equipo no funcione con normalidad, y una temperatura perjudicial podría dañar los productos que se guardan en el interior del equipo.



Carga máxima del estante: 40 kg



No almacene en este equipo sustancias explosivas como, por ejemplo, aerosoles con propelente inflamable.

No coloque ningún producto por debajo del soporte inferior del estante ni por encima de la marca de la línea de carga superior.

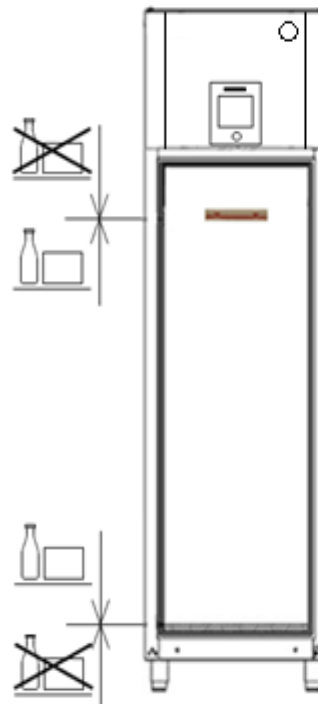

Do not store goods above the top loading mark

Do not store goods below the bottom grate

Funcionamiento del producto (controlador Evco – modelo RU1)

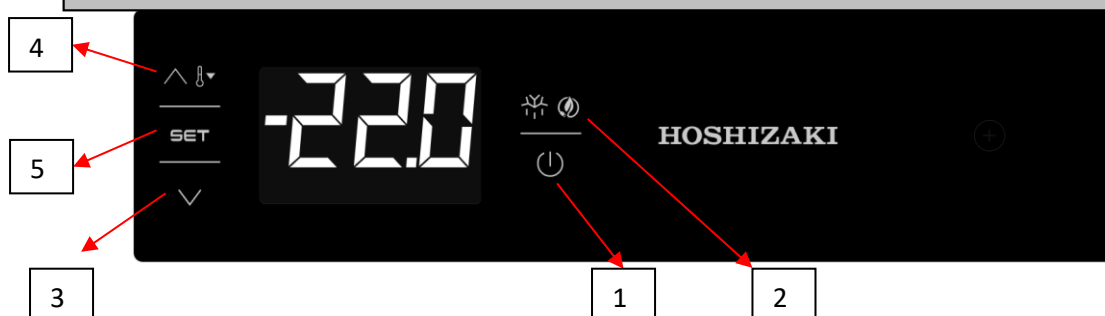

➤ FUNCIONES DEL PANEL FRONTAL

Para bloquear las teclas de la tapa delantera, mantenga pulsado AUX (3) y On / Stand By (1) durante 2 segundos: si las teclas están bloqueadas se mostrará en pantalla el texto "Loc", mientras que si no lo están se mostrará el texto "UnL".

1) Si se mantiene pulsado **ON/STAND BY** durante 4 segundos, el dispositivo se abre o se cierra. (Encendido/Apagado)

2) Si se pulsa el botón **MANUAL DEFROST** durante 4 segundos, se inicia la descongelación manual. Si la refrigeración excesiva está activa y la temperatura del evaporador no es adecuada, no se iniciará la descongelación manual.

3) Tecla **DOWN**: permite desplazarse hacia abajo en el menú o reducir el valor. Si se mantiene pulsada durante 4 segundos, se activa la superrefrigeración. Cuando está activa una función de refrigeración excesiva, la temperatura establecida se puede reducir. El tiempo y la temperatura se determinan con la ayuda de los parámetros. Cuando está activada una función de refrigeración excesiva, el dispositivo no descongela nunca.

4) Tecla **UP**: permite desplazarse hacia arriba en el menú o aumentar el valor. Si se mantiene pulsada durante 4 segundos, se activa la función de porcentaje de humedad relativa baja y alta. (Para algunos modelos) Se muestra "rhL" en la pantalla (la función de porcentaje bajo de humedad relativa está activa) o se muestra "rhH" en la pantalla (la función de porcentaje alto de humedad relativa está activa). Estas funciones aparecen en la pantalla durante 10 segundos. Si el control de humedad no está disponible, se muestra «----» en la pantalla durante 1 segundo.

5) Tecla **SET**: tecla para introducir y cambiar los valores ajustables.

➤ FUNCIONAMIENTO

A continuación se indican los casos de funcionamiento disponibles:

Estado «**On**»: el dispositivo está activado y funciona.

Estado «**Stand-By**»: el dispositivo está apagado, pero aún está conectado.

Estado «**Off**»: para apagar el dispositivo, retire el enchufe de la toma o desconecte el fusible principal.

Funcionamiento del producto (controlador Danfoss AK - CC55)

Puesta en marcha:

Enchufe el equipo.

Asegúrese de que el interruptor principal de 2 polos esté conectado.

Descripción de la pantalla (AK-UI55):

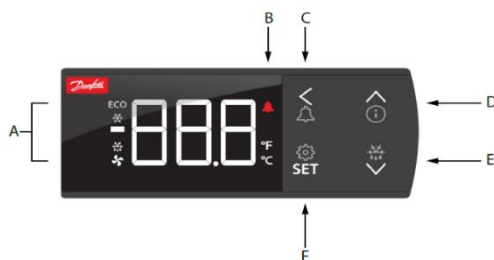

Partes de la pantalla	Descripción
A	Se enciende en caso de: <ul style="list-style-type: none"> - Optimización de la energía (ECO) - Refrigeración - Descongelación - Funcionamiento del ventilador
B	Luces en caso de alarma
C	Con un pulsación larga (3 segundos) del botón de alarma (se reinicia el relé), se muestra el código de alarma.
D	Una pulsación larga (3 segundos) da acceso al menú de información « Inf ». (Observe la figura « b ») Flecha arriba/flecha abajo/flecha a la izquierda: navegación por el menú y ajuste de valores.
E	Con una pulsación larga (3 segundos) se inicia una descongelación, se muestra « -d- » en la pantalla. La descongelación en curso se puede detener con una pulsación larga.
F	SET: una pulsación larga (3 segundos) permite acceder al menú « SET ». Si la operación está bloqueada con una contraseña, se muestra « PS ». Introduzca el código. * Muestra el ajuste de un parámetro elegido/guarda un ajuste modificado. Una pulsación corta da acceso a la introducción del límite de desconexión del termostato.

* El ajuste de fábrica de P89 es «0», este paso se saltará si no hay ningún valor introducido.

HOSHIZAKI

Premier Remote Cabinets



a- Lista de parámetros del botón «SET»

b- Lista de parámetros del botón «Info»

SET	←	SET button, 3 s: Configuration settings
Set		
(PS) v	←	PS: Password (if any)
cFg	SET →	
v		
r--		
A--		
c--		
d--		
n--		
F--		
t--		
h--		
o--		
p--		
q--		
u--		
<		
(Return)		

r12	Main switch
o61	Application
o03	MODBUS address
r89	Food type
r00	Cut-out temperature
r15	Ther. sensor S4 %
r61	Ther. sensor S4% night
A36	Alarm sensor S4%
o17	Display air S4%
o30	Refrigerant type
o20	Min. transmitter range
o21	Max. transmitter range
d01	Defrost method
d03	Defrost interval
d10	Defrost sensor
d04	Max. defrost time
d02	Defrost stop temperature
<	
(Return)	

Menu groups
See also the following pages.

^	←	Info button, 3 s: Information for service use
Inf		
StA	SET	See control state message
App	SET	See selected application
in	SET →	
out	SET →	
buS	SET	MODBUS quality
SoF	SET	See SW version
<		
(Return)		

do1	*	Read output status
do2	*	
do3	*	
do4	*	
Ao1	**	
<		(Return)

Al1	(PE)	Read input status
Al2	**	
Al3	**	
Al4	**	
Al5	**	
di1	**	
di2	**	
<		(Return)

Output status
When you want info on a relay output, the dot will show whether the relay is activated (energized)
for e.g.:
do4 = not activated
do.4 = activated

HOSHIZAKI

Premier Remote Cabinets



Mensajes de error (alarmas)

En una situación de error, se encenderá el LED de alarma de la parte delantera y se activará el relé de alarma (dependiendo de la prioridad). Si pulsa el botón de alarma durante 3 segundos, podrá ver el informe de alarma en la pantalla.



Para obtener más información, consulte el manual del controlador del modelo CO2 seleccionado. (Danfoss AK-CC55 Compact)

Code	Alarm text	Description
E01	Hardware failure	The controller has a hardware failure
E06	Clock lost time	Clock has lost valid time
E20	Pe Evap. pressure A - Sensor error	Sensor signal is out of range. Please check the sensor for correct operation
E24	S2 Gas outlet A - Sensor error	Sensor signal is out of range. Please check the sensor for correct operation
E25	S3 Air ON evap. A - Sensor error	Sensor signal is out of range. Please check the sensor for correct operation
E26	S4 Air OFF evap. A - Sensor error	Sensor signal is out of range. Please check the sensor for correct operation
E27	S5 Evaporator A - Sensor error	Sensor signal is out of range. Please check the sensor for correct operation
A01	High temperature alarm A	The alarm temperature has been above the max alarm limit for a longer time period than the set alarm delay.
A02	Low temperature alarm A	The alarm temperature has been below the min alarm limit for a longer time period than the set alarm delay.
A04	Door open alarm	The door has been open for a too long time
A05	Max defrost hold time exceeded	The controller has been waiting longer time than permitted after a co-ordinated defrost.
A11	Refrigerant not selected	The refrigerant has not been selected hence control can not be initiated
A15	DI alarm 1	Alarm signal from digital input signal
A16	DI alarm 2	Alarm signal from digital input signal
A45	Main switch set OFF	The controller main switch has been set to either Stop or Manual control. Alternatively a digital input set up for "main switch" function, has stopped control
A59	Case in cleaning mode	A case cleaning operation has been started on a case
AA2	CO ₂ leak detected	CO ₂ is leaking from the refrigeration system
AA3	Refrigerant leak detected	Refrigerant is leaking from the refrigeration system
a04	Wrong IO configuration	Inputs and outputs have not been configured correctly

Funcionamiento del producto (controlador Carel MPXpro)

Puesta en marcha

Enchufe el equipo.

El controlador del armario se entrega encendido de forma predeterminada. Esto significa que el controlador empezará a funcionar cuando se conecte la alimentación y el interruptor principal esté en la posición de encendido.

Encender y apagar el armario

Para encender/apagar el armario se utiliza el interruptor principal de 2 polos, situado en el lado izquierdo de la caja de control principal, en el «compartimento del compresor».

Pantalla

Diseño/descripción de la pantalla:





La pantalla que se muestra arriba tiene una lectura de tres dígitos.

Dentro del área de lectura, hay varios LED que proporcionan las siguientes indicaciones.

En general = Cuando un LED parpadea la activación se retrasa o se limita.

 = Refrigeración encendida (cuando está encendido este LED, la refrigeración está activada)

 = Ventilador interno en funcionamiento (cuando está encendido este LED, el ventilador interno/del evaporador está activado)

 = Descongelación encendida (cuando está encendido este LED, hay un ciclo de descongelación en curso)

 = Si el LED parpadea, indica que la puerta está abierta o que hay una alarma o un error.

HACCP = Cuando se enciende este LED, la alarma HACCP está activa. Cuando este LED parpadea, hay una alarma HACCP guardada.



Botones:

Los 4 botones situados en el lado derecho de la pantalla se utilizan para acceder y ajustar diferentes parámetros. Estos botones se pueden pulsar solos o en combinación con el fin de accionar el controlador.

Los ajustes que se describen a continuación son los únicos que el usuario final debe cambiar. El usuario final no debe modificar ningún parámetro que no se describa aquí. Todos los demás ajustes deben ser realizados por un técnico experto.

AJUSTES DE USUARIO

Ajuste de la temperatura del armario



: arriba



: abajo



:Set



: Prg/mute

- Mantenga pulsado Set durante el funcionamiento normal hasta que la pantalla comience a parpadear; la temperatura del armario se puede ajustar con las teclas arriba y abajo .
- Cuando se haya ajustado a la temperatura deseada, se pulsa brevemente Set para guardar el nuevo valor y volver al funcionamiento normal.

Cómo realizar una descongelación manual

- Si la temperatura de la sonda del evaporador es lo suficientemente fría, mantenga pulsada la tecla def durante más de 5 segundos durante el funcionamiento normal para realizar una descongelación manual.
- Cuando se enciende el símbolo de descongelación  , indica que hay una descongelación en curso.
- Si def se mantiene pulsada durante más de 5 segundos cuando hay un ciclo de descongelación en curso, esta se desactivará.

Cómo silenciar las alarmas acústicas

- Cuando el controlador está en modo de alarma, se oirá una señal acústica. La alarma se puede silenciar pulsando la tecla Prg/mute .

HOSHIZAKI

Premier Remote Cabinets



Ajustar los límites de la alarma de temperatura

- Para abrir la lista de parámetros, mantenga pulsada la tecla Prg/mute durante más de 5 segundos durante el funcionamiento normal. La pantalla mostrará /c1.
- Pulse Prg/mute . Se muestra la primera categoría de parámetros, «Pro».
- Pulse UP hasta llegar a la categoría «ALn», indicada por el icono  que se ilumina en la pantalla.
- Al pulsar Set se mostrará el parámetro AA.
- Pulse UP hasta llegar a A1.
- Pulse Set para realizar el ajuste si los valores de AL (umbral de temperatura de **Alarm Low** [alarma baja]) y AH (umbral de temperatura de **Alarm High** [alarma alta]) serán (0 = en relación con los valores de temperatura del armario) o (1 = absoluto) valor predeterminado = 1.
- Pulse Set para guardar el ajuste elegido y volver a A1.
- Pulse UP hasta llegar a AL (umbral de temperatura **Alarm Low** [alarma baja]).
- Pulse Set para poder ajustar la AL con las teclas arriba y abajo (ajustable entre -50 y +50), ajuste predeterminado = -50 °C.
- Pulse Set para guardar el ajuste elegido y volver a AL.
- Pulse UP hasta alcanzar AH (umbral de temperatura de **Alarm High** [alarma alta]).
- Pulse Set para poder ajustar la AH con las teclas arriba y abajo (ajustable entre -50 y +50), ajuste predeterminado = +50 °C.
- Pulse Set para guardar el ajuste elegido y volver a AH.
- Pulse UP hasta alcanzar Ad (tiempo de **Alarm Delay** [retardo de la alarma] para AL y AH).
- Pulse Set para poder ajustar el Ad con las teclas arriba y abajo (ajustable entre 0 y 240 minutos), ajuste predeterminado = 120 minutos.
- Pulse Set para guardar el ajuste elegido y volver a Ad.
- Mantenga pulsado Prg/mute durante más de 5 segundos para guardar los cambios y volver al menú principal.

Para crear umbrales de alarma de temperatura y tiempo de retardo de alarma adecuados para un refrigerador o un congelador, se pueden sugerir los siguientes ejemplos de ajuste de alarma:

	Valor	A1	AL	AH	Ad
Refrigerador	+5 °C	1	+1 °C	+8 °C	120 min.
Congelador	-18 °C	1	-50 °C	-15 °C	120 min.



Cómo mostrar el registro de alarmas

- Mantenga pulsadas las teclas Prg/mute y Set durante 5 segundos.
- Introduzca la contraseña: 44.
- Pulse Set para acceder a un submenú en el que se utilizan las teclas UP y DOWN para desplazarse por las distintas alarmas, HS0 a HS9.

- Seleccione una alarma y pulse Set para mostrar el código, la hora, los minutos y la duración.
- A partir de cualquiera de los subparámetros, al pulsar Prg/mute el controlador volverá al parámetro principal «HSx».

- Pulse Prg/mute durante 5 segundos para volver a la pantalla

estándar. Ejemplo:

«HI» -> «h17» -> «m23» -> «65»

indica que la alarma «HI» (alarma de alta temperatura) se activó a las 17:23 y duró 65 minutos.

ALARMAS HACCP

Se gestionan dos tipos de eventos HACCP:

- alarmas de tipo HA, alta temperatura durante la operación;
- alarmas de tipo HF, alta temperatura después de un fallo de alimentación (corte de energía).

Cuando se registra una alarma, parpadea el LED HACCP, la pantalla muestra el código de alarma, se guarda la alarma y se activan el relé de alarma y el timbre.

Cómo mostrar las alarmas HA y HF

- Pulse Prg/mute y DOWN simultáneamente.

- Desplácese por la lista de alarmas pulsando UP y DOWN

- Pulse Set para seleccionar la alarma correspondiente.
- Utilice UP o DOWN para ver la descripción de la alarma: año, mes, día, hora, minutos y duración en minutos de la alarma seleccionada.

- Pulse Prg/mute de nuevo para volver a la lista anterior.

Además, el menú de alarma HACCP permite las siguientes operaciones:



Cómo eliminar una alarma HACCP

- Pulse Set y DOWN durante 5 segundos al visualizar la lista de alarmas.

Esto hace que la HACCP parpadee, la pantalla muestra el mensaje rES y se reinicializa la supervisión de las alarmas HACCP.

Cómo borrar toda la memoria de las alarmas HACCP

- Pulse Set y UP y DOWN durante 5 segundos.

Este procedimiento muestra el mensaje rES, elimina toda la memoria de alarmas y reinicia la supervisión de las alarmas HACCP.

Para poder utilizar las alarmas HACCP, es necesario que la empresa instaladora haya ajustado el reloj en tiempo real antes de entregar el armario al usuario final. Estos ajustes están protegidos por un código de acceso y, por lo tanto, no pueden ser realizados por el usuario final.

Luz del armario

En todos los armarios, la luz se coloca en la parte exterior, encima de la puerta. Esta luz es activada por el controlador principal, lo que significa que no se puede cambiar la forma de funcionamiento.

Cuando se abre la puerta del armario, se enciende la luz situada encima de la puerta. Al cerrar la puerta, esta luz se apaga.

HOSHIZAKI

Premier Remote Cabinets



Errores y alarmas

Display code	Cause of the alarm	Icon flash on display	Alarm relay	Buzzer	Reset	Compressor	Defrost	Evaporator fans	Continuous cycle	Signalled on tLAN	Network solenoid valve
rE	Control probe fault		ON	ON	automatic	duty setting(c4)	unchanged	unchanged	unchanged	√	-
E1	Probe S1 fault		OFF	OFF	automatic	duty setting(c4)	unchanged	unchanged	unchanged	√	-
E2	Probe S2 fault		OFF	OFF	automatic	unchanged	unchanged	unchanged	unchanged	√	-
E3	Probe S3 fault		OFF	OFF	automatic	unchanged	unchanged	unchanged	unchanged	√	-
E4	Probe S4 fault		OFF	OFF	automatic	unchanged	unchanged	unchanged	unchanged	√	-
E5	Probe S5 fault		OFF	OFF	automatic	unchanged	unchanged	unchanged	unchanged	√	-
E6	Probe S6 fault		OFF	OFF	automatic	unchanged	unchanged	unchanged	unchanged	√	-
E7	Probe S7 fault		OFF	OFF	automatic	unchanged	unchanged	unchanged	unchanged	√	-
E8	Serial probe S8 not updated		OFF	OFF	automatic	duty setting(c4)	unchanged	unchanged	unchanged	√	-
E9	Serial probe S9 not updated		OFF	OFF	automatic	duty setting(c4)	unchanged	unchanged	unchanged	√	-
E10	Serial probe S10 not updated		OFF	OFF	automatic	duty setting(c4)	unchanged	unchanged	unchanged	√	-
E11	Serial probe S11 not updated		OFF	OFF	automatic	duty setting(c4)	unchanged	unchanged	unchanged	√	-
LO	Low temperature alarm		ON	ON	automatic	unchanged	unchanged	unchanged	unchanged	√	-
HI	High temperature alarm		ON	ON	automatic	unchanged	unchanged	unchanged	unchanged	√	-
LO2	Low temperature alarm		ON	ON	automatic	unchanged	unchanged	unchanged	unchanged	√	-
HI2	High temperature alarm		ON	ON	automatic	unchanged	unchanged	unchanged	unchanged	√	-
IA	Immediate alarm from external contact		ON	ON	automatic	duty setting(A6)	unchanged	unchanged	unchanged	√	-
dA	Delayed alarm from external contact		ON	ON	automatic	duty setting(A6) if A7≠0	unchanged	unchanged	unchanged	√	-
dor	Door open for too long alarm		ON	ON	automatic	unchanged	unchanged	unchanged	unchanged	√	-
Etc	Real time clock fault		OFF	OFF	automatic	unchanged	unchanged	unchanged	unchanged	√	-
LSH	Low superheat alarm		OFF	OFF	automatic	OFF	unchanged	unchanged	unchanged	√	√
LSA	Low suction temperature alarm		OFF	OFF	automatic / manual	OFF (paragraph 6.10)	unchanged	unchanged	unchanged	√	√
MOP	Maximum evaporation pressure alarm		OFF	OFF	automatic	OFF	unchanged	unchanged	unchanged	√	√
LOP	Low evaporation temperature alarm		OFF	OFF	automatic	unchanged	unchanged	unchanged	unchanged	√	√
bLo	Valve blocked alarm		OFF	OFF	manual/ disabled with P14=0	unchanged	unchanged	unchanged	unchanged	√	-
Edc	Communication error with stepper driver		ON	ON	automatic	unchanged	unchanged	unchanged	unchanged	√	-
EFS	Stepper motor broken/not connected		ON	ON	automatic	unchanged	unchanged	unchanged	unchanged	√	-
EE	Flash unit parameter error		OFF	OFF	automatic	OFF	not performed	OFF	not performed	√	-
EF	EEPROM operating parameter error		OFF	OFF	automatic	OFF	not performed	OFF	not performed	√	-
HA	Type HA HACCP alarm	HACCP	OFF	OFF	manual	unchanged	unchanged	unchanged	unchanged	√	-
HF	Type HF HACCP alarm	HACCP	OFF	OFF	manual	unchanged	unchanged	unchanged	unchanged	√	-
MA	Communication error with Master (only on Slave)		ON	ON	automatic	unchanged	unchanged	unchanged	unchanged	-	-
u1...u5	Communication error with Slave (only on Master)		ON	ON	automatic	unchanged	unchanged	unchanged	unchanged	-	-
n1...n5	Alarm on unit 1 to 5 in the network		ON	ON	automatic	unchanged	unchanged	unchanged	unchanged	-	-
up1...up5	Upload procedure with errors on unit 1 to 5		OFF	OFF	-	unchanged	unchanged	unchanged	unchanged	-	-
GPE	Error in custom gas parameters		ON	ON	automatic	OFF	not performed	OFF	not performed	√	-



Para obtener más información, consulte el manual del controlador del modelo CO2 seleccionado. (Carel MPX PRO)



Funcionamiento del producto (sin controlador – modelo NC)



Consulte el manual suministrado con el controlador instalado.

Resolución de problemas

Ruido:

- Si se produce un ruido anómalo, solicite servicio de asistencia.
- Los sonidos del funcionamiento del ventilador interior son normales.
- Si hacen ruido las piezas de metal, los paneles frontales o los paneles situados delante del compartimento, es posible que estén abiertos. Cierre los paneles.

Escarcha en el interior del compartimento:

- Humedad ambiente demasiado alta.
- La puerta se abre con demasiada frecuencia.
- La puerta se ha dejado abierta demasiado tiempo.
- La junta de la puerta está dañada. Compruebe detenidamente si presenta daños.

Bajo rendimiento de refrigeración:

- Temperatura ambiente demasiado alta.
- La puerta se abre con demasiada frecuencia o durante demasiado tiempo.
- La puerta se ha dejado abierta.
- La junta de la puerta está dañada.
- La temperatura está ajustada demasiado alta.
- Hay demasiados alimentos en el equipo y la entrada/salida de aire están obstruidas.
- Alimentos calientes en el interior del equipo.
- Descongelación en curso. La temperatura del armario puede elevarse temporalmente durante el ciclo de descongelación sin que afecte a los alimentos que están en su interior. El LED de descongelación está encendido.

Algunos de los alimentos están congelados:

- Hay demasiados alimentos en el equipo y la entrada/salida de aire están obstruidas.
- El ajuste de temperatura es demasiado bajo.
- El ventilador del evaporador podría estar averiado.

Condensación alrededor de la puerta:

- Humedad ambiente demasiado alta.
- La puerta no cierra de forma estanca.
- La junta de la puerta está dañada.
- El parámetro relacionado con el calefactor del marco de la puerta no se ha ajustado correctamente.

Consumo de energía demasiado alto:

- Temperatura ambiente demasiado alta.
- La puerta se abre con demasiada frecuencia o durante demasiado tiempo.
- La puerta se ha dejado abierta.
- La junta de la puerta está dañada.
- El ajuste de temperatura es demasiado bajo.
- Hay demasiados alimentos en el equipo y la entrada/salida de aire están obstruidas.
- Se han introducido alimentos templados o calientes en el equipo.
- El equipo se ha colocado directamente a la luz del sol o cerca de superficies que emiten calor.
- Se han cambiado los ajustes predeterminados.



Agua de descongelación

Durante la descongelación, el equipo produce agua, que se introduce en el sistema de reevaporación a través de una pieza de plástico de vacío situada en la parte superior del armario (en armarios Premier).

El agua se reevapora con un elemento de calefacción eléctrico y un motor ventilador. En raras ocasiones, el patrón de uso del armario crea más agua de la que el producto es capaz de reevaporar, lo que significa que puede producirse un desbordamiento de agua. Si esto ocurre, se puede cambiar el elemento de calefacción eléctrico para que funcione al 100 % o bien desconectarla y, en su lugar, conectar el tubo de agua de la parte trasera a un desagüe. Estos cambios debe realizarlos un técnico de servicio cualificado.

Mecanismo de cierre de la puerta

La puerta está equipada con un sistema de cierre automático. Si se abre menos de 90°, se cerrará sola. Si se abre más de 90°, permanecerá abierta.

La puerta se puede abrir utilizando el pedal. Esto deja ambas manos libres para colocar los alimentos en el armario.

Fallo de alimentación

En caso de fallo de alimentación, el control recuerda el ajuste de temperatura y reinicia el producto cuando se restaura la alimentación.

Limpieza

Una limpieza insuficiente hará que el producto no funcione con un rendimiento óptimo o, eventualmente, que se averíe.



Antes de limpiar el producto, desconéctelo siempre.



No enjuague el producto con agua y no utilice chorros de agua ni mangueras de vapor, ya que podría provocar cortocircuitos en el sistema eléctrico.



No deben utilizarse productos de limpieza que contengan cloro o compuestos de cloro, así como otros medios corrosivos, ya que podrían causar corrosión en los paneles inoxidable del armario y del evaporador.



El producto debe mantenerse libre de polvo y suciedad. Para ello, lo mejor es utilizar un aspirador y un cepillo.



Para realizar el mantenimiento externo, utilice un producto abrillantador para acero inoxidable.



El interior del equipo debe limpiarse con una solución jabonosa suave a intervalos adecuados y revisarse minuciosamente antes de volver a ponerlo en funcionamiento.

Juntas de puerta

Este capítulo trata de la importancia de un buen funcionamiento de la junta de la puerta.

Las juntas son una parte importante de un refrigerador/congelador. Si las juntas no funcionan correctamente, se reduce la estanqueidad del armario. Esta falta de estanqueidad puede provocar un aumento de la humedad, la formación de hielo en el interior, la formación de hielo en el evaporador (lo que reduce la capacidad de refrigeración) y, en el peor de los casos, la reducción de la vida útil del armario.



Por lo tanto, es importante conocer el estado de la junta. Se recomienda realizar inspecciones periódicas.

La junta debe limpiarse con frecuencia con una solución jabonosa suave. Si es necesario sustituir una junta, póngase en contacto con su proveedor.

Almacenamiento a largo plazo

Si el producto se deja de utilizar y debe prepararse para un almacenamiento prolongado, limpie a fondo el compartimento interior, la puerta y la junta de la puerta con un paño húmedo jabonoso caliente. Los posibles restos de comida podrían crear moho.

Mantenimiento

Si falla la refrigeración, averigüe primero si el equipo se ha desconectado o apagado involuntariamente de la toma de corriente o si se ha fundido un fusible.

Si no es posible encontrar la causa del fallo de refrigeración, póngase en contacto con el instalador de la unidad.

Cuando se ponga en contacto con HOSHIZAKI o con el instalador, por favor, indíquenos el nombre y el número de serie del armario que se encuentran en el interior. Esta información figura en la placa de características.

HOSHIZAKI

Premier Remote Cabinets



Datos técnicos

Colocación de la etiqueta:

PRODUCT DESCRIPTION LABEL																														
1 Product Number		<table border="1" style="width: 100%; border-collapse: collapse;"> <tr> <td style="width: 80%;">PRODUCT NUMBER</td> <td style="width: 20%; text-align: center;">1</td> </tr> <tr> <td colspan="2" style="text-align: center;"> </td> </tr> <tr> <td>PRODUCT DESCRIPTION</td> <td style="text-align: center;">2</td> </tr> <tr> <td>MODEL</td> <td style="text-align: center;">3</td> </tr> <tr> <td>REFRIGERANT</td> <td style="text-align: center;">4</td> </tr> <tr> <td>CO2 EQUIVALENT</td> <td style="text-align: center;">5</td> </tr> <tr> <td>IP PROTECTION</td> <td style="text-align: center;">6</td> </tr> <tr> <td>CLIMATE CLASS</td> <td style="text-align: center;">7</td> </tr> <tr> <td>PRODUCTION DATE</td> <td style="text-align: center;">8</td> </tr> <tr> <td>TOTAL POWER / CURRENT / LAMP POWER</td> <td style="text-align: center;">9</td> </tr> <tr> <td>VOLTAGE - FREQUENCY</td> <td style="text-align: center;">10</td> </tr> <tr> <td>HEATING ELEMENT</td> <td style="text-align: center;">11</td> </tr> <tr> <td>SYSTEM PRESSURE</td> <td style="text-align: center;">12</td> </tr> <tr> <td>BLOWING AGENT</td> <td style="text-align: center;">13</td> </tr> </table>	PRODUCT NUMBER	1			PRODUCT DESCRIPTION	2	MODEL	3	REFRIGERANT	4	CO2 EQUIVALENT	5	IP PROTECTION	6	CLIMATE CLASS	7	PRODUCTION DATE	8	TOTAL POWER / CURRENT / LAMP POWER	9	VOLTAGE - FREQUENCY	10	HEATING ELEMENT	11	SYSTEM PRESSURE	12	BLOWING AGENT	13
PRODUCT NUMBER		1																												
PRODUCT DESCRIPTION		2																												
MODEL		3																												
REFRIGERANT		4																												
CO2 EQUIVALENT		5																												
IP PROTECTION		6																												
CLIMATE CLASS		7																												
PRODUCTION DATE		8																												
TOTAL POWER / CURRENT / LAMP POWER		9																												
VOLTAGE - FREQUENCY		10																												
HEATING ELEMENT		11																												
SYSTEM PRESSURE		12																												
BLOWING AGENT	13																													
2 Product Description																														
3 Model																														
4 Refrigerant (GWP)																														
5 CO2 Equivalent																														
6 IP Protection																														
7 Climate Class																														
8 Production Date																														
9 Total power / Current / Lamp power																														
10 Voltage - Frequency																														
11 Heating Element																														
12 System Pressure																														
13 Blowing Agent																														
14 Serial Number		<p>S/N: 14</p> <p>HOSHIZAKI EUROPE B.V. Burgemeester Stramanweg 101 1101 AA Amsterdam, The Netherlands</p> <div style="display: flex; justify-content: space-around; align-items: center;"> </div>																												

Trade mark			HOSHIZAKI			
Model name			PREMIER U 70	PREMIER U 140	PREMIER U 80	PREMIER U 60
Usado previsto			Storage	Storage	Storage	Storage
Temperatura operativa de			X	X	X	X
Temperatura operativa de			X	X	X	X
Armario multiusos						
Armario vertical			X	X	X	X
Armario mostrador						
Parameter	Symbol	Unit				
Volumen bruto	VnT	L	700	1400	700	480
Clase climática			CC5	CC5	CC5	CC5
Tensión de suministro/Frecuencia	V / Hz		230 - 50	230 - 50	230 - 50	230 - 50
Refrigerante (armario CO2)			CO2	CO2	CO2	CO2
Refrigerante (armario RU-1)			HFC / HFO Refrigerant*	HFC / HFO Refrigerant*	HFC / HFO Refrigerant*	HFC / HFO Refrigerant*
Datos de contacto:	HOSHIZAKI EUROPE B.V. Address: Burgemeester Stramanweg 101 1101 AA Amsterdam, The Netherlands Tel: +31 (0)20 691 84 99 - http://hoshizaki.europe.com/					

* Refrigerantes compatibles con el tubo de orificio (R449A, R448A, R45A, etc. Compruebe la ficha técnica del orificio utilizado).

HOSHIZAKI

Premier Remote Cabinets



Trade mark			HOSHIZAKI		
Model name			BAKER U 950	BAKER GA 950	PREMIER SF 950
Uso previsto			Storage	Cooling /Freezing / Storage / Proving	Cooling / Shock Freezing
Temperatura operativa de			X	X	X
Temperatura operativa de			X	X	X
Armario multiusos				X	X
Armario vertical			X	X	X
Armario mostrador					
Parameter	Symbol	Unit			
Volumen bruto	VnT	L	1000	950	950
Clase climática			CC5	CC5	CC5
Tensión de suministro/Frecuencia	V / Hz		230 - 50	230 – 50	230 – 50
Refrigerante (armario RU-1)			HFC / HFO Refrigerant*	HFC / HFO Refrigerant*	HFC / HFO Refrigerant*
Datos de contacto:	HOSHIZAKI EUROPE B.V. Address: Burgemeester Stramanweg 101 1101 AA Amsterdam, The Netherlands Tel: +31 (0)20 691 84 99 - http://hoshizaki.europe.com/				

* Refrigerantes compatibles con el tubo de orificio (R449A, R448A, R45A, etc. Compruebe la ficha técnica del orificio utilizado).

HOSHIZAKI

Premier Remote Cabinets



Dimensiones

PREMIER U 70

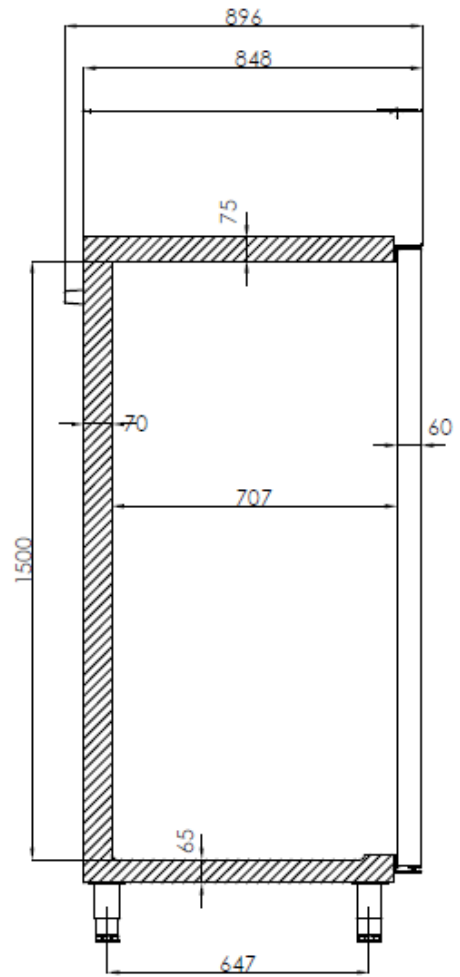
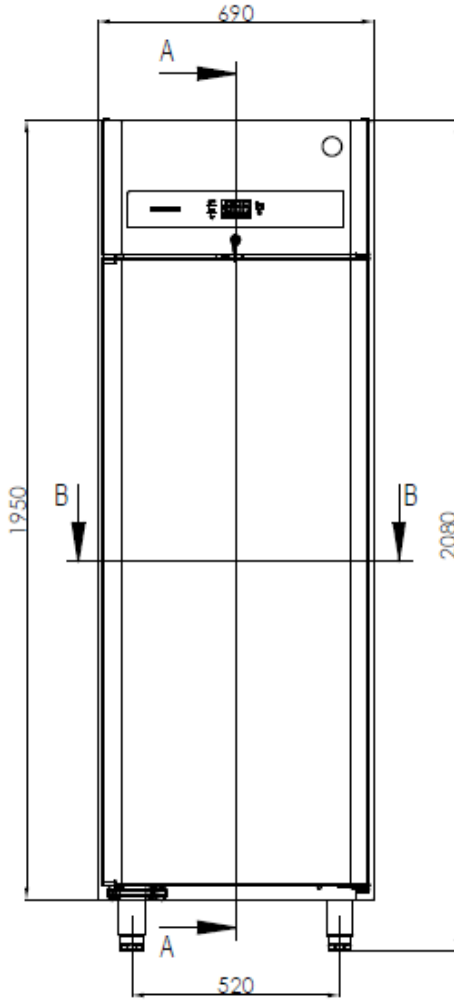

A-A

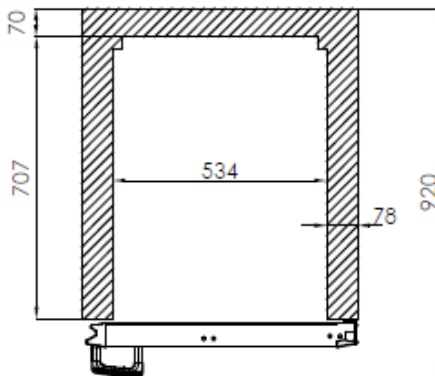

B-B

HOSHIZAKI

Premier Remote Cabinets



PREMIER U 60

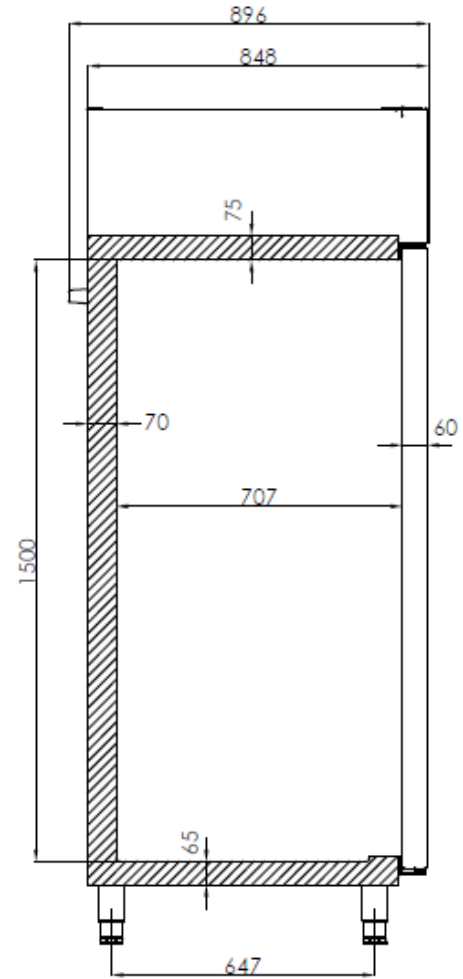
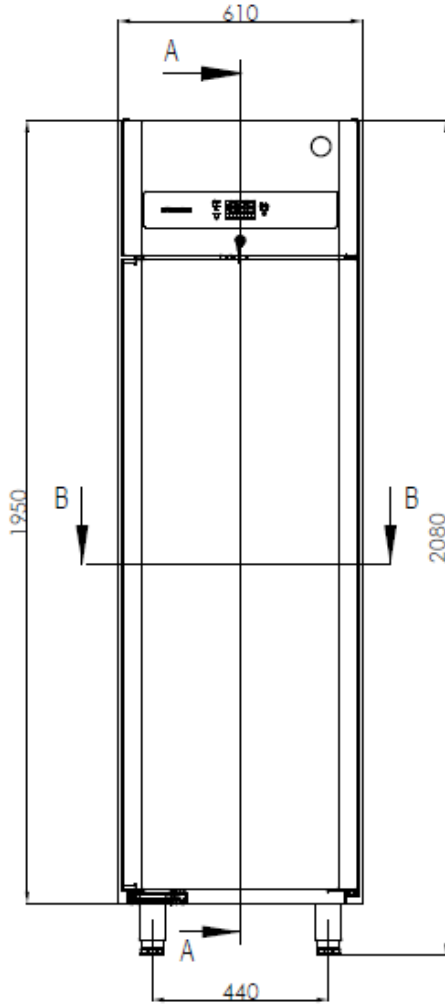

A-A

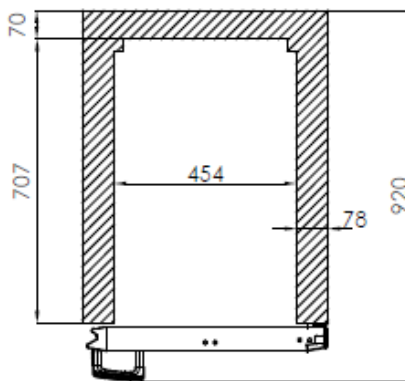

B-B

HOSHIZAKI

Premier Remote Cabinets



PREMIER U 80

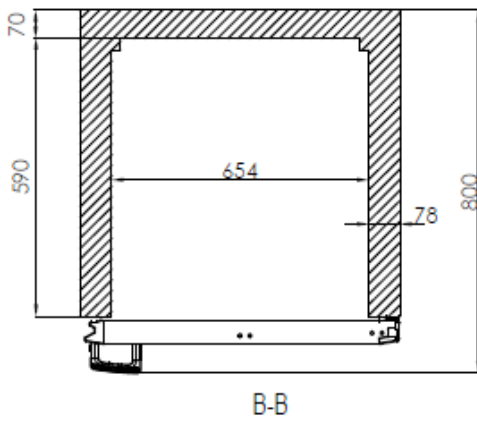
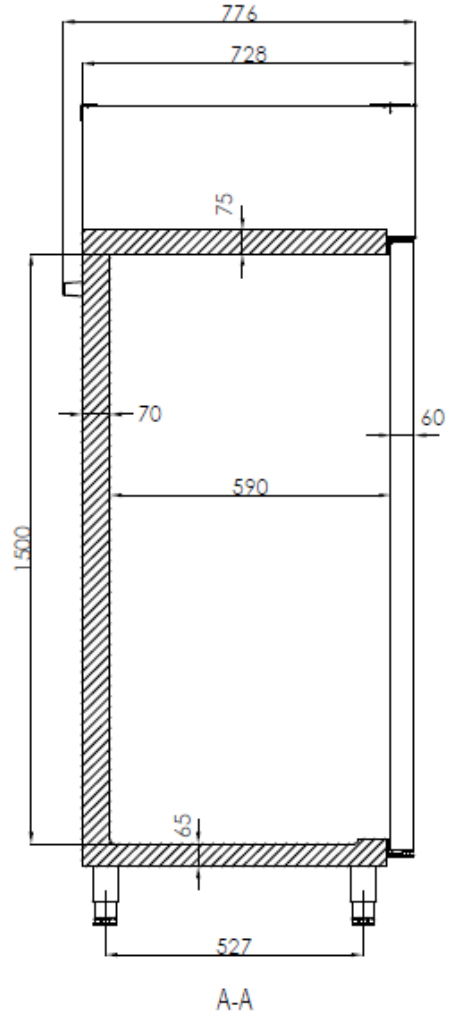
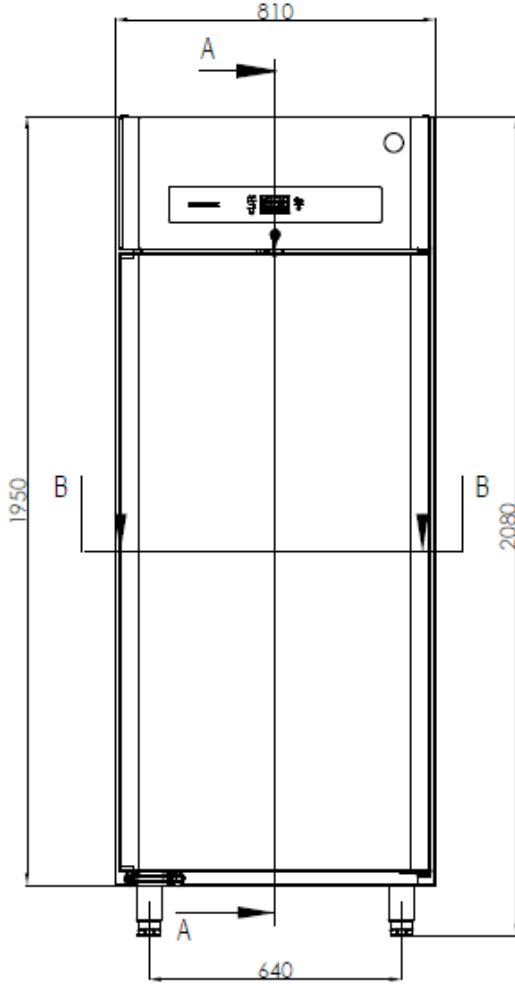

HOSHIZAKI

Premier Remote Cabinets



PREMIER U 140

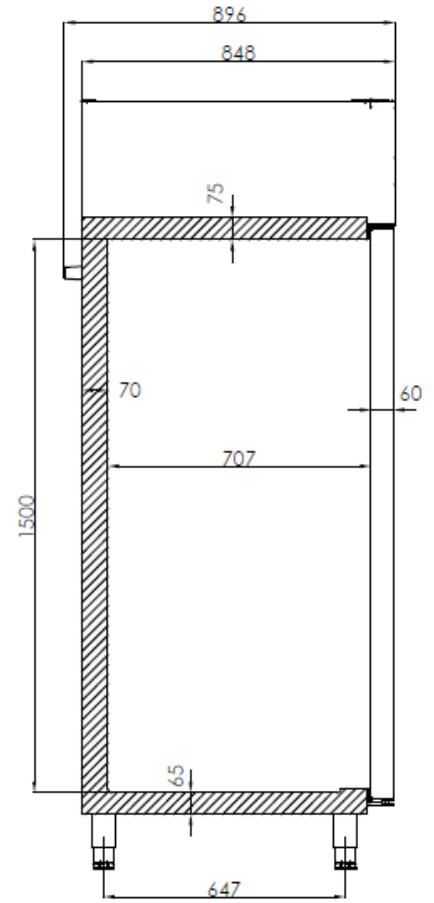
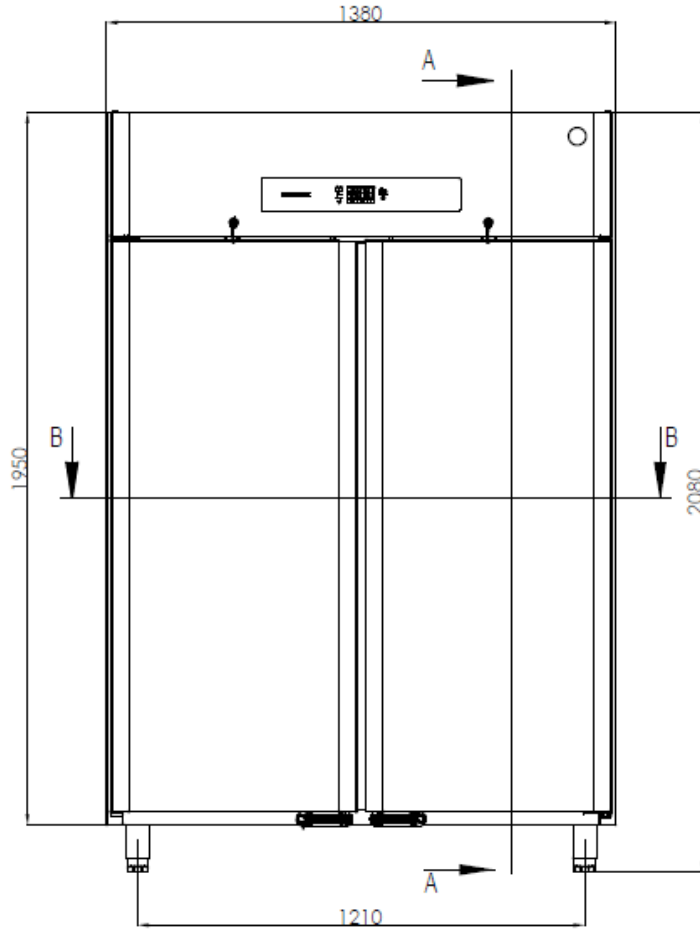

A-A

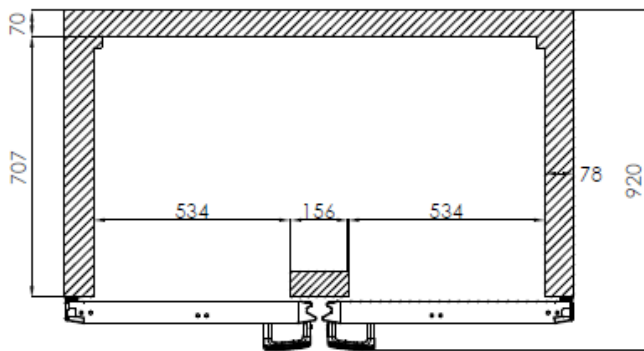

B-B

HOSHIZAKI

Premier Remote Cabinets



BAKER U 950

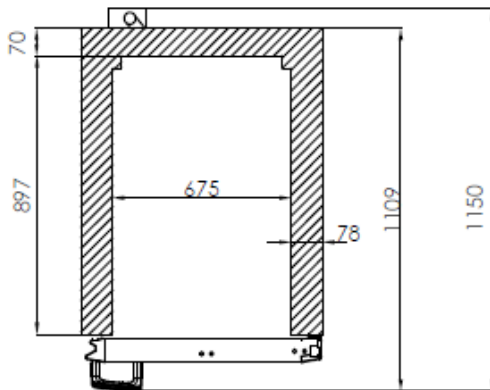
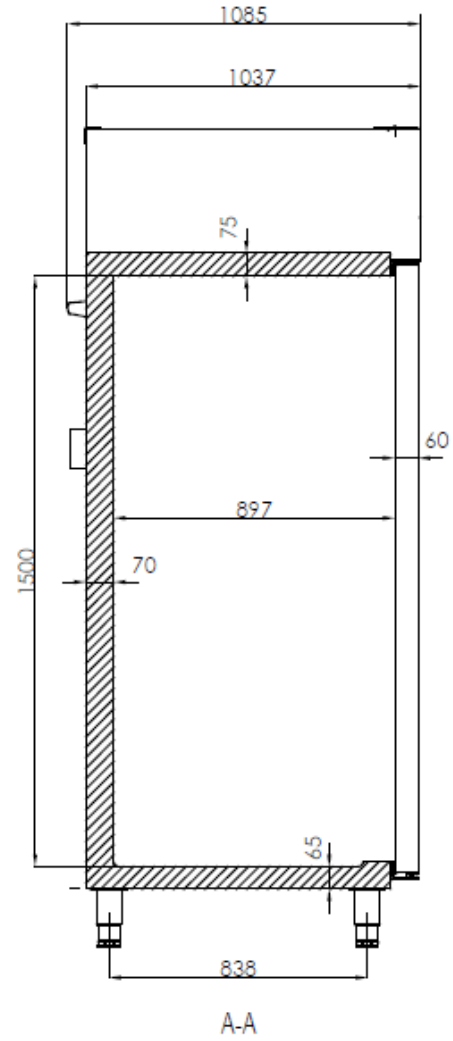
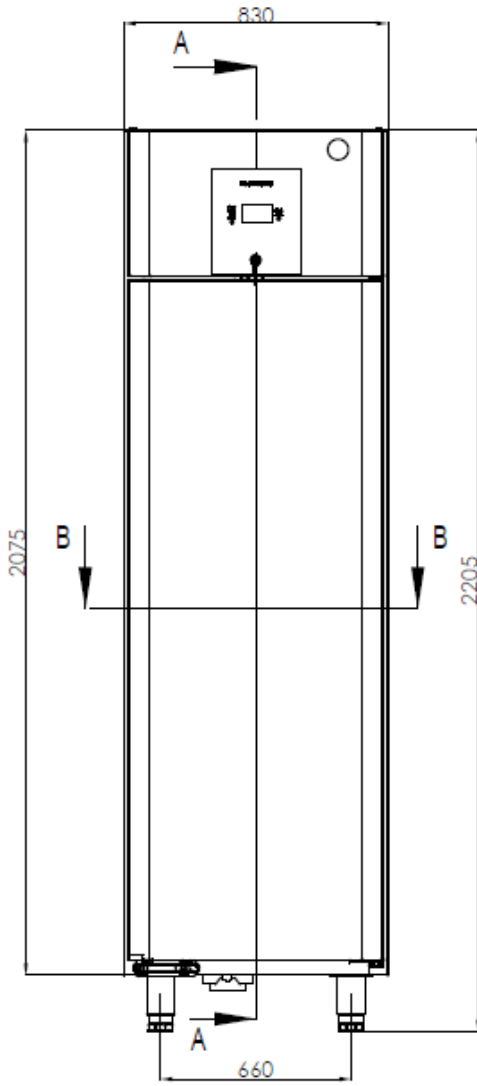

HOSHIZAKI

Premier Remote Cabinets



BAKER GA 950 (RU1)

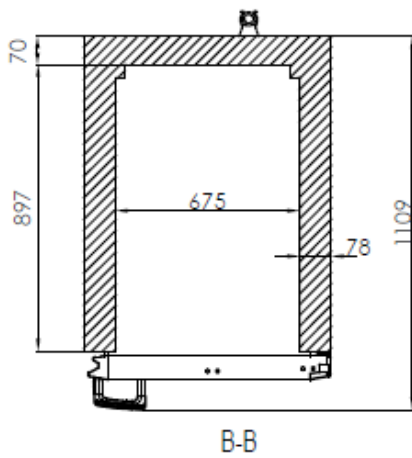
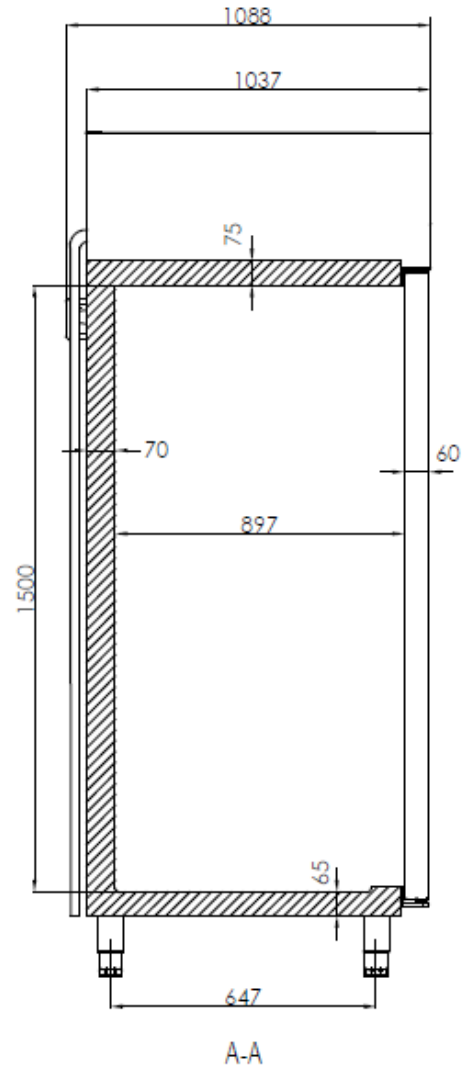
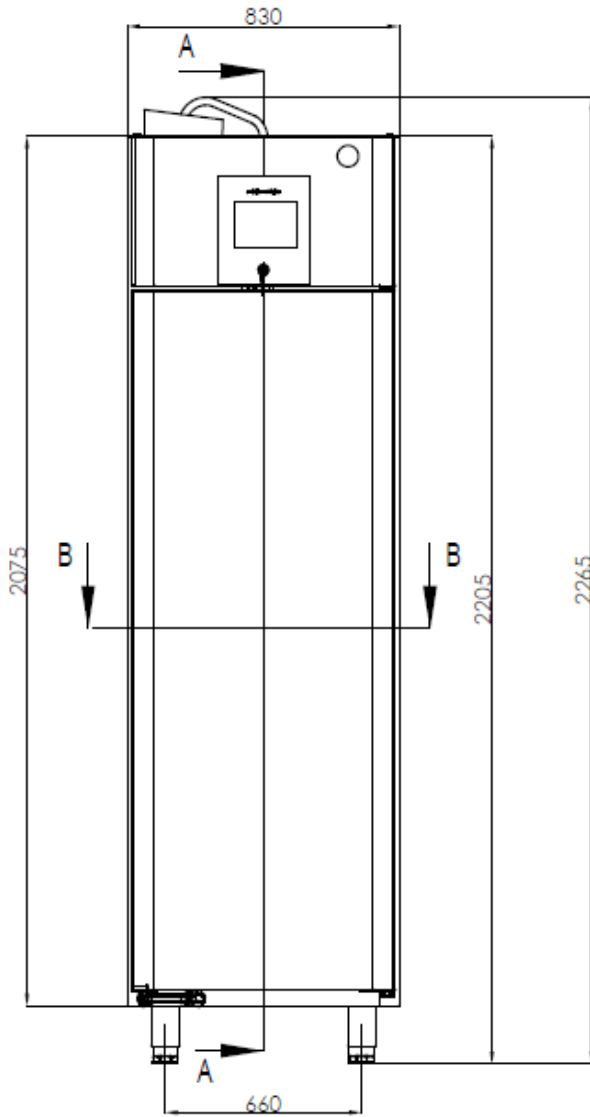

HOSHIZAKI

Premier Remote Cabinets



BAKER SF 950 (RU1)

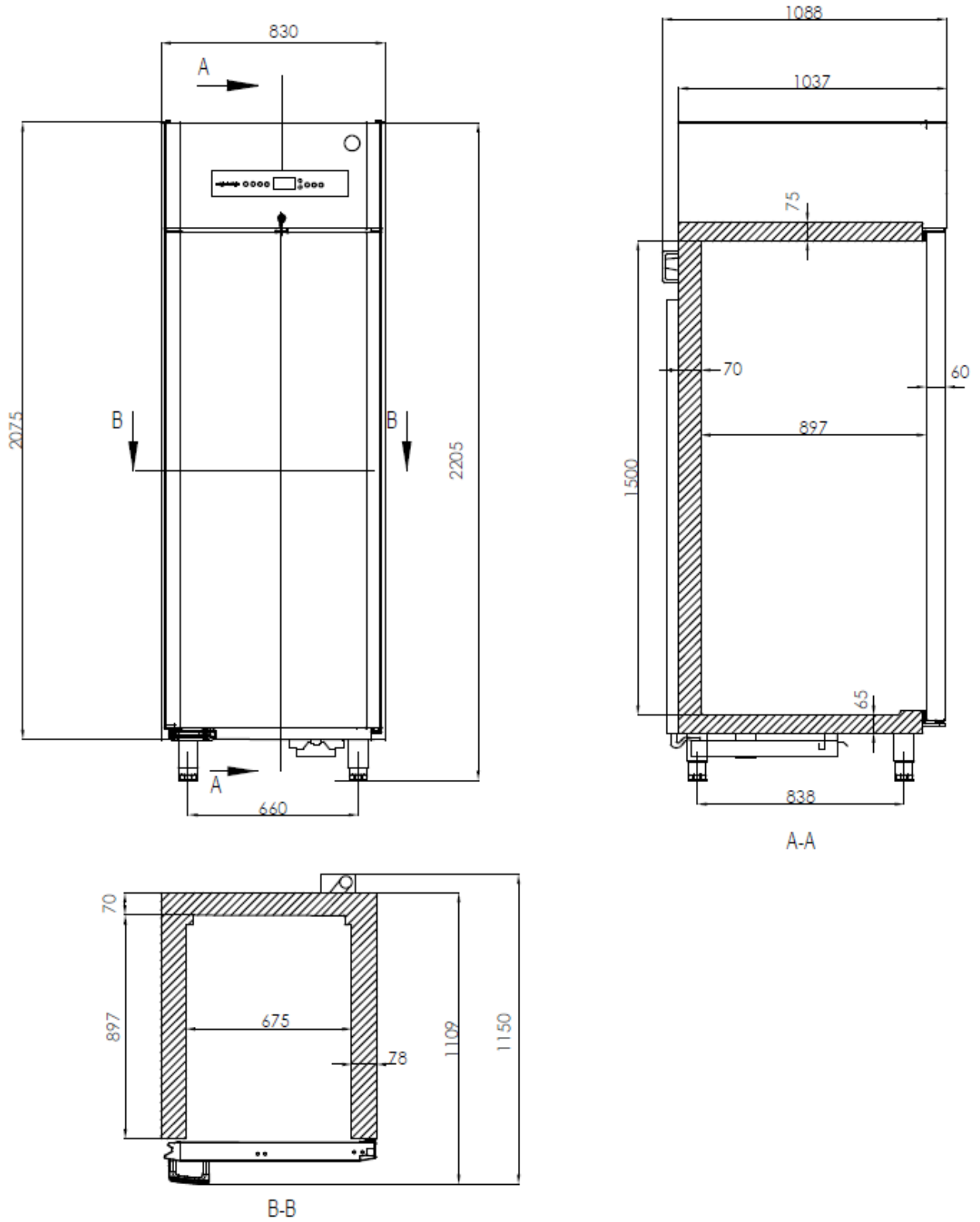

Desecho

Lo que se indica a continuación solo afecta al Reino Unido.

La retirada de un armario viejo solo está disponible cuando entregamos uno nuevo al mismo tiempo. Los armarios deben estar completamente descongelados y vacíos antes de la recogida.

Hoshizaki reconoce que nuestros productos para el mercado de la restauración se consideran RAEE cuando pierden su utilidad. Para garantizar que las responsabilidades de Hoshizaki se gestionan de forma correcta y respetuosa con el medio ambiente, hemos suscrito el mayor programa de cumplimiento entre empresas del Reino Unido: B2B Compliance, <http://www.b2bcompliance.org.uk>

B2B Compliance se ocupará en nuestro nombre de todas las áreas de nuestras responsabilidades a la hora de recoger y eliminar equipos que entran dentro de la normativa RAEE del Reino Unido. Puede ponerse en contacto con B2B Compliance en el número de teléfono 01691 676124.





Diagramas de cableado eléctrico

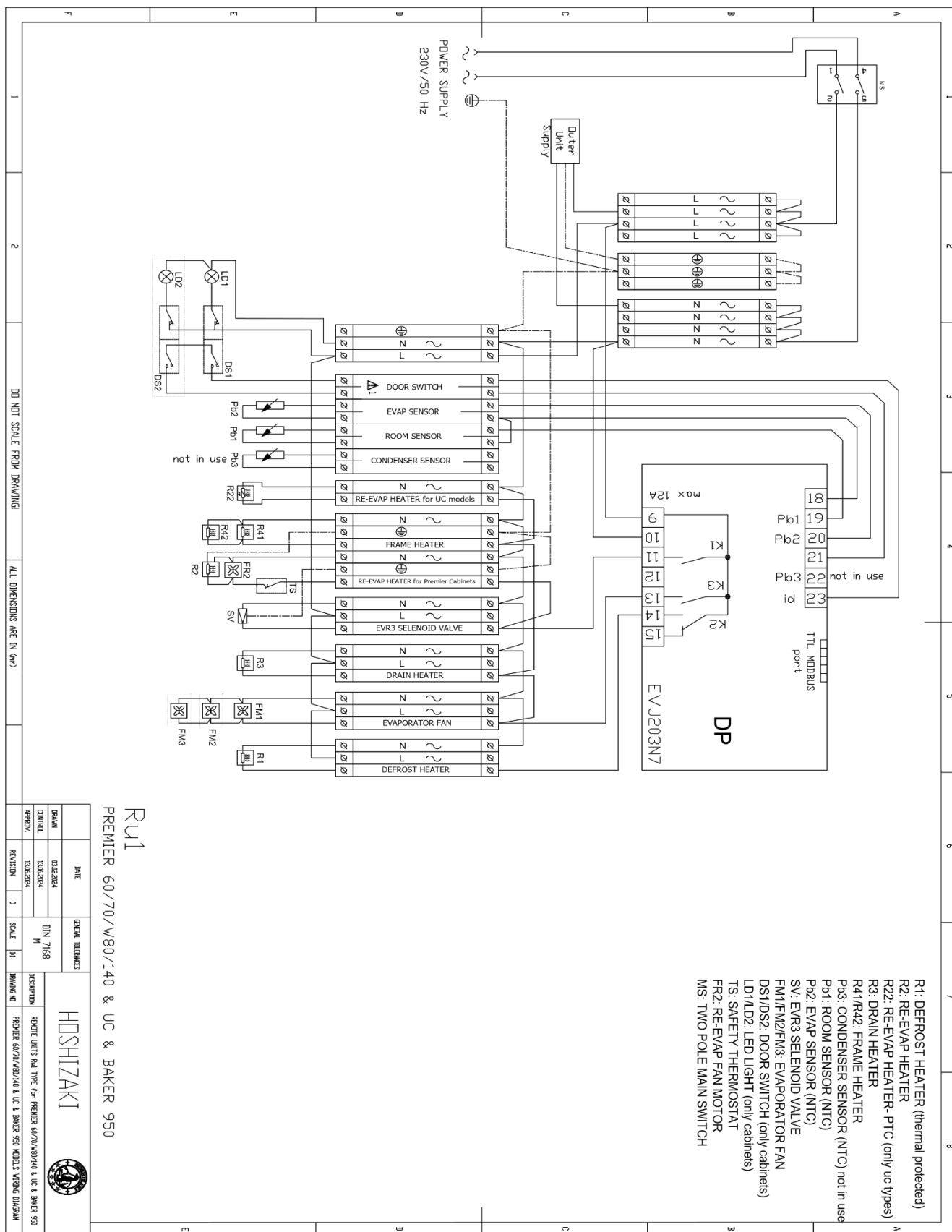

RU1
PREMIER 60/70/W/80/140 & UC & BAKER 950

DATE		GENERAL TOLERANCES		DESCRIPTION
DATE	03/28/2014	DIN	7168	
CONTROL	13/02/2014	M		
APPROVAL	13/02/2014			
REVISION	0	SCALE	1:1	DRAWING NO: PREMIER 60/70/W/80/140 & UC & BAKER 950 MODEL'S VARIANTE DISEÑO



HOSHIZAKI Premier Remote Cabinets

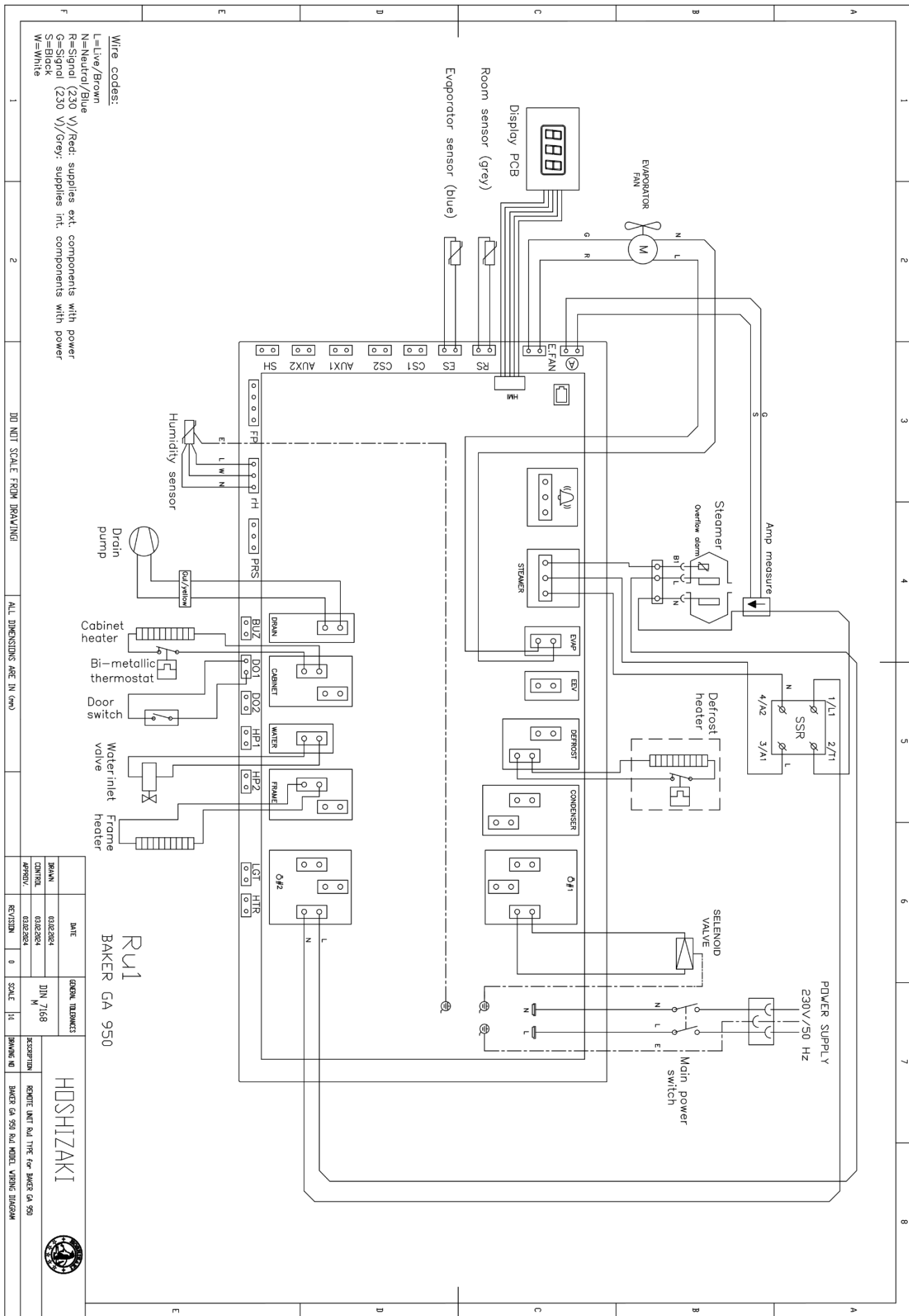

DO NOT SCALE FROM DRAWING

ALL DIMENSIONS ARE IN (mm)

DATE		GENERAL DIMENSIONS		HOSHIZAKI	
BRAN.	03/25/2024	DIN	7168		
CONTROL	03/25/2024	M			
APPROV.	03/25/2024	SCALE	1:1		
REVISION	0	DRAWING NO		REMOTE UNIT RU1 TYPE FOR BAKER GA 950 BAKER GA 950 RU1 MODEL WIRING DIAGRAM	

RU1
BAKER GA 950

HOSHIZAKI

Premier Remote Cabinets

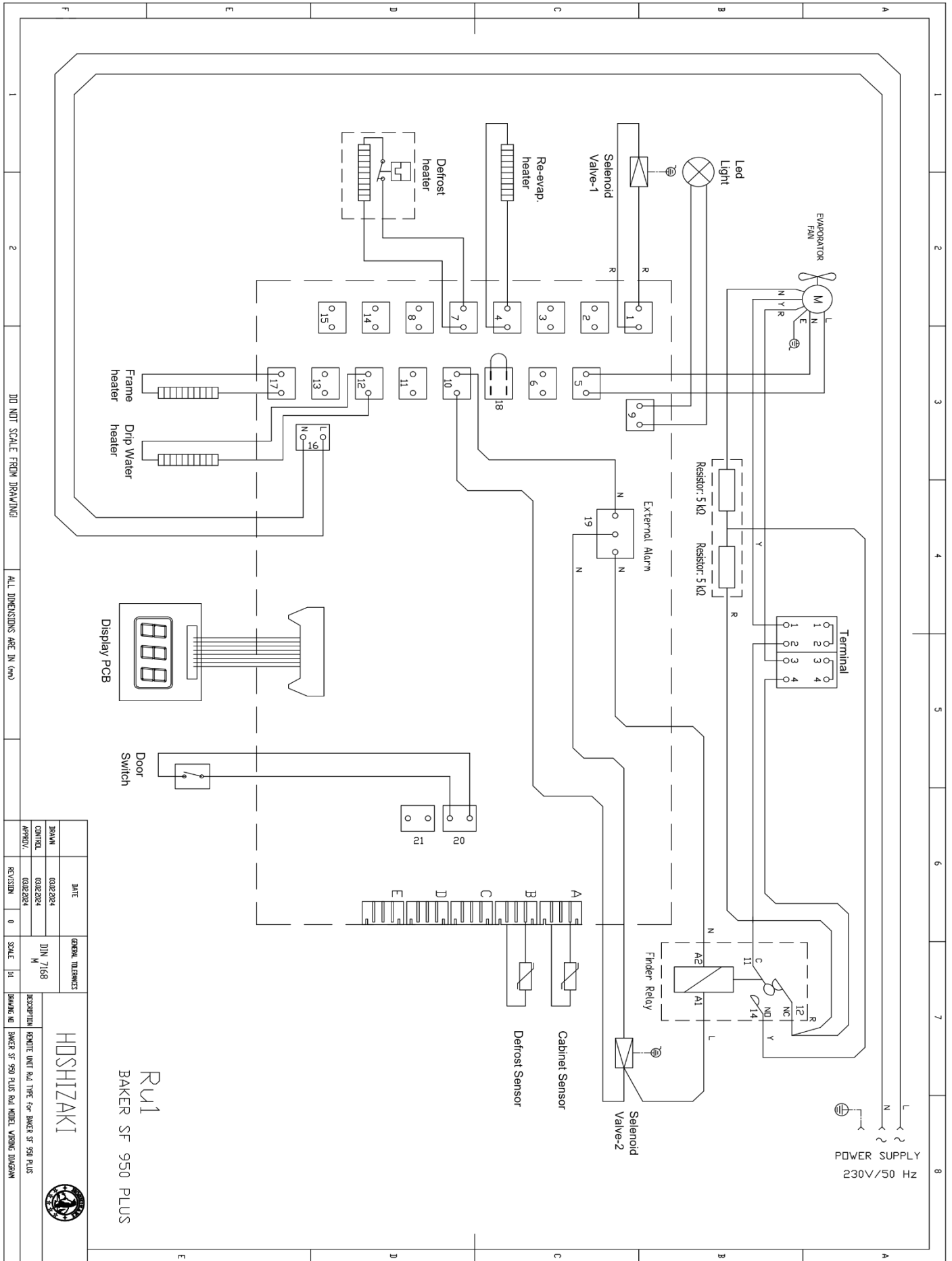

RU1
BAKER SF 950 PLUS

DO NOT SCALE FROM DRAWING

ALL DIMENSIONS ARE IN (mm)

GENERAL DIMENSIONS		DATE	
DRAWN	03022024	DATE	03022024
CONTROL	03022024	REVISION	0
APPROV.	03022024	SCALE	1:1

HOSHIZAKI



RECEPTION REPORT UNIT RAU TYPE FOR BAKER SF 950 PLUS
DRAWING NO BAKER SF 950 PLUS RAU MODEL VARIOUS DIMENSION

HOSHIZAKI Premier Remote Cabinets

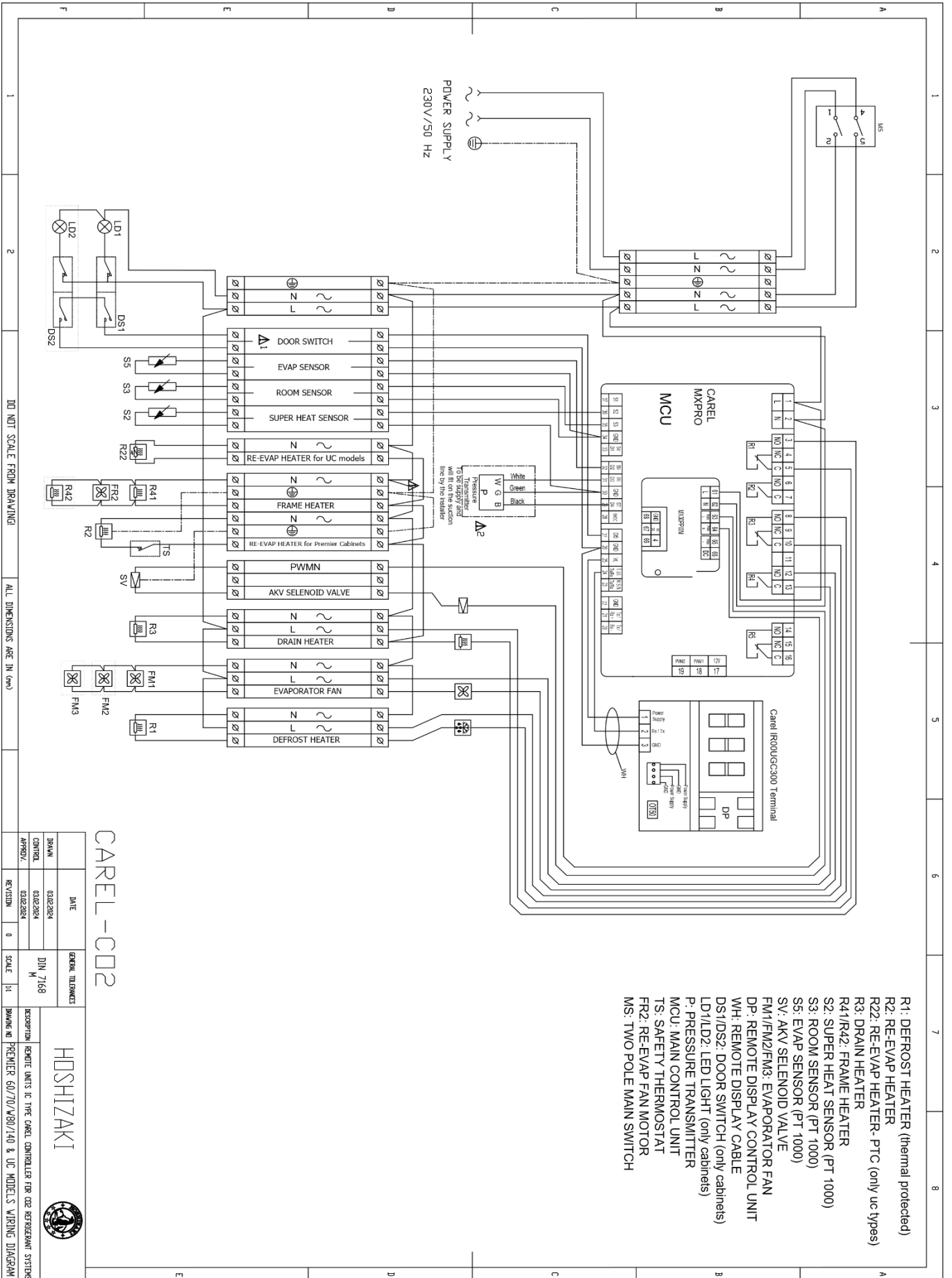

DO NOT SCALE FROM DRAWING

ALL DIMENSIONS ARE IN (mm)

CAREL-C02

DATE		GENERAL TOLERANCES	
DATE	03/02/2024	GENERAL TOLERANCES	DIN 7168
DESIGN	03/02/2024	SCALE	1:1
CONTROL	03/02/2024	REVISION	0
APPROVAL	03/02/2024	DESCRIPTION REMOTE UNITS IC TYPE CAREL CONTROLLER FOR CEE REFRIGERANT SYSTEMS	
		PREMIER 60/70/V80/140 & UC MODELS WIRING DIAGRAM	

HOSHIZAKI



HOSHIZAKI

Premier Remote Cabinets

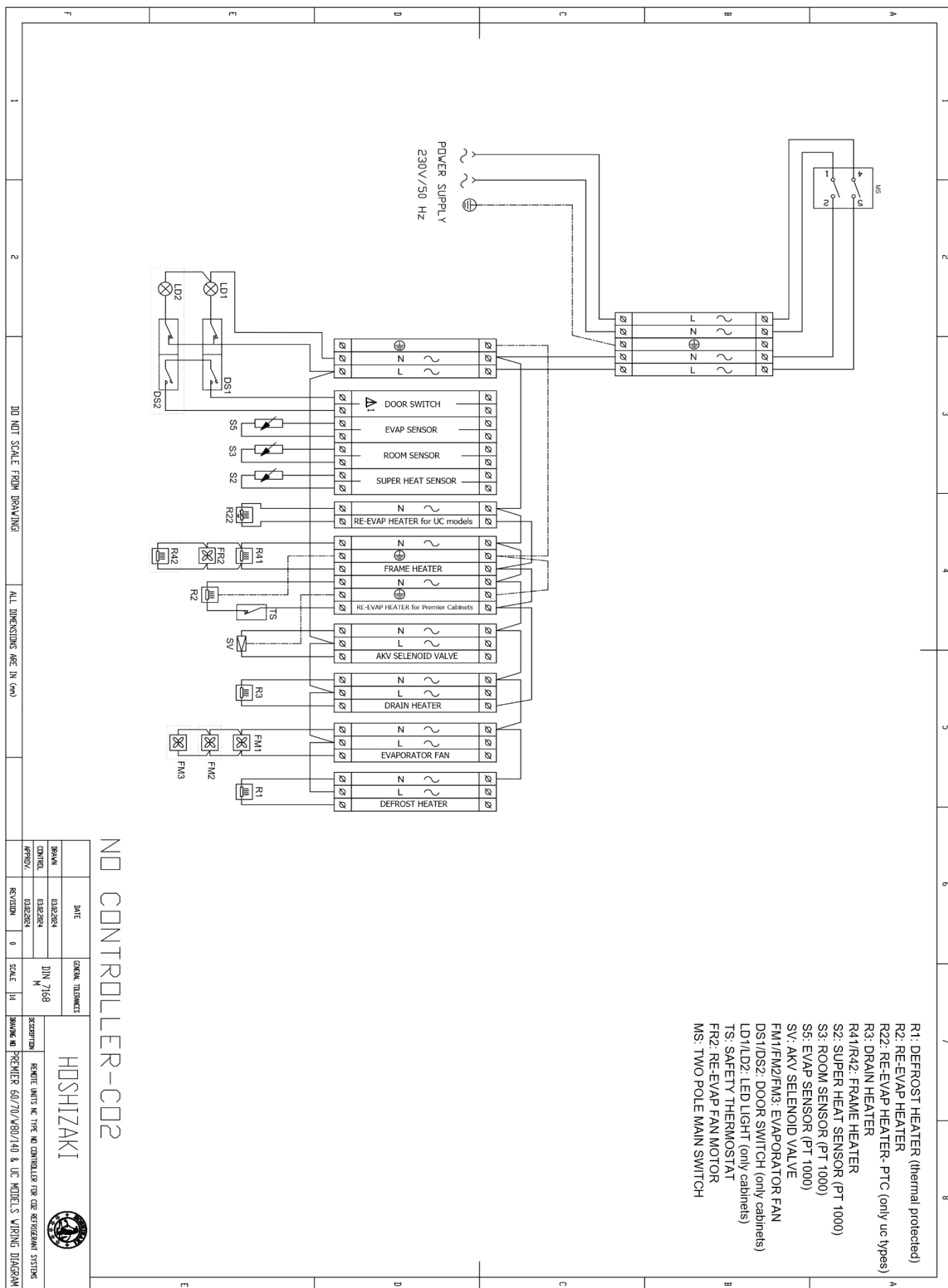

- R1: DEFROST HEATER (thermal protected)
- R2: RE-EVAP HEATER
- R22: RE-EVAP HEATER- PTC (only uc types)
- R3: DRAIN HEATER
- R41/R42: FRAME HEATER
- S2: SUPER HEAT SENSOR (PT 1000)
- S3: ROOM SENSOR (PT 1000)
- S5: EVAP SENSOR (PT 1000)
- SV: AKV SELENOID VALVE
- FM1/FM2/FM3: EVAPORATOR FAN
- DS1/DS2: DOOR SWITCH (only cabinets)
- LD1/LD2: LED LIGHT (only cabinets)
- TS: SAFETY THERMOSTAT
- FR2: RE-EVAP FAN MOTOR
- MS: TWO POLE MAIN SWITCH



Diagramas de refrigeración

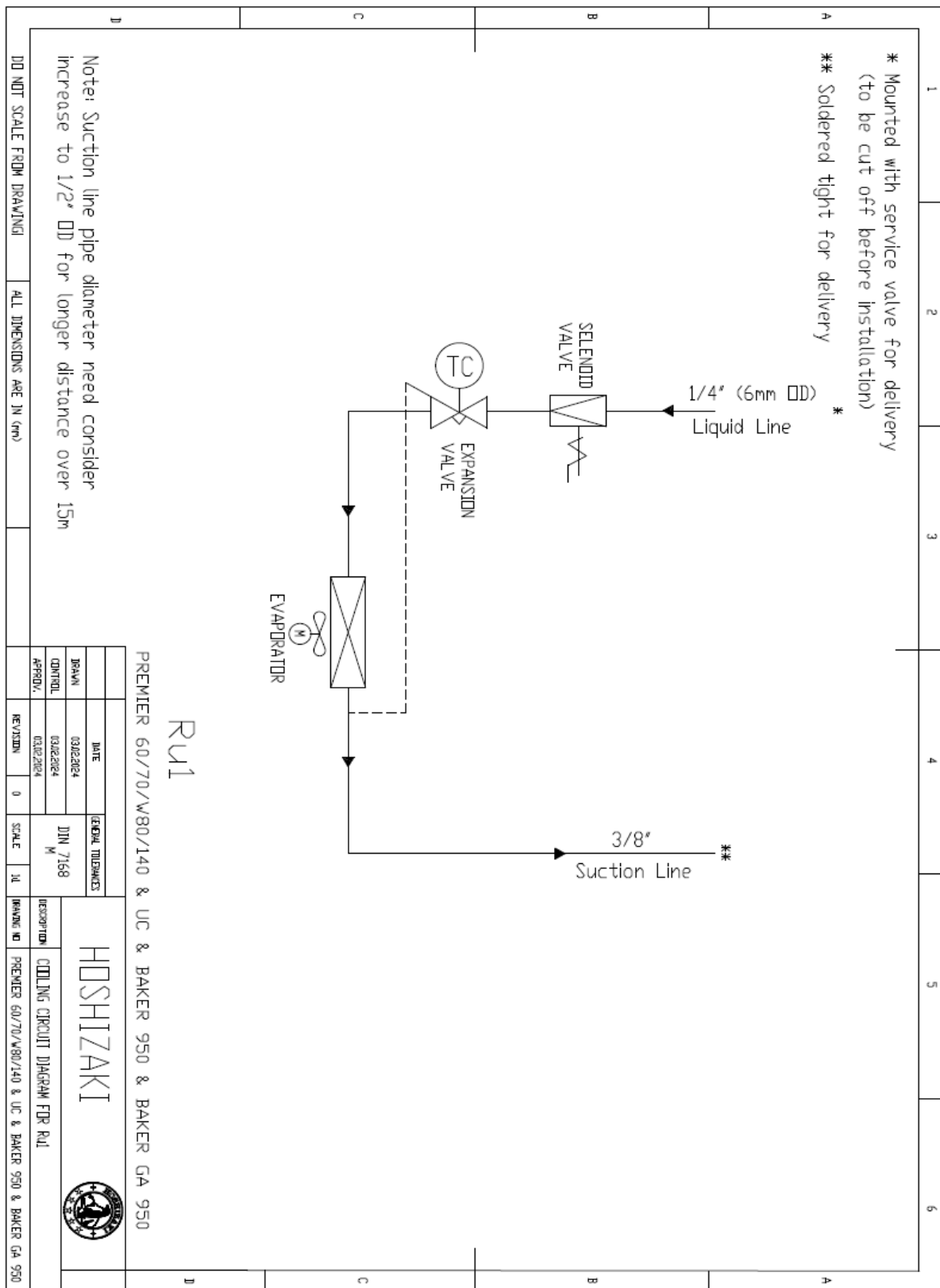

HOSHIZAKI

Premier Remote Cabinets

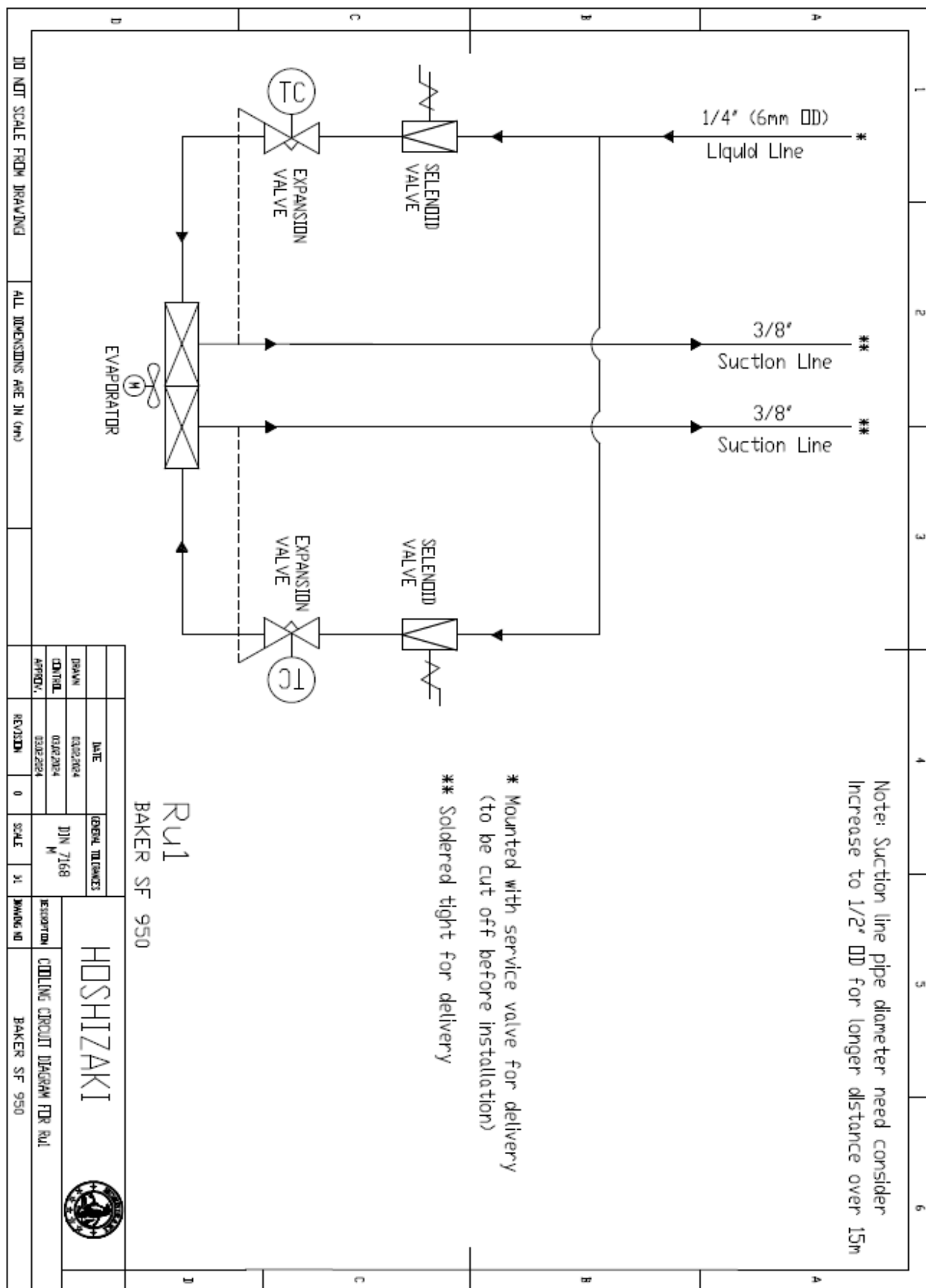

HOSHIZAKI

Premier Remote Cabinets

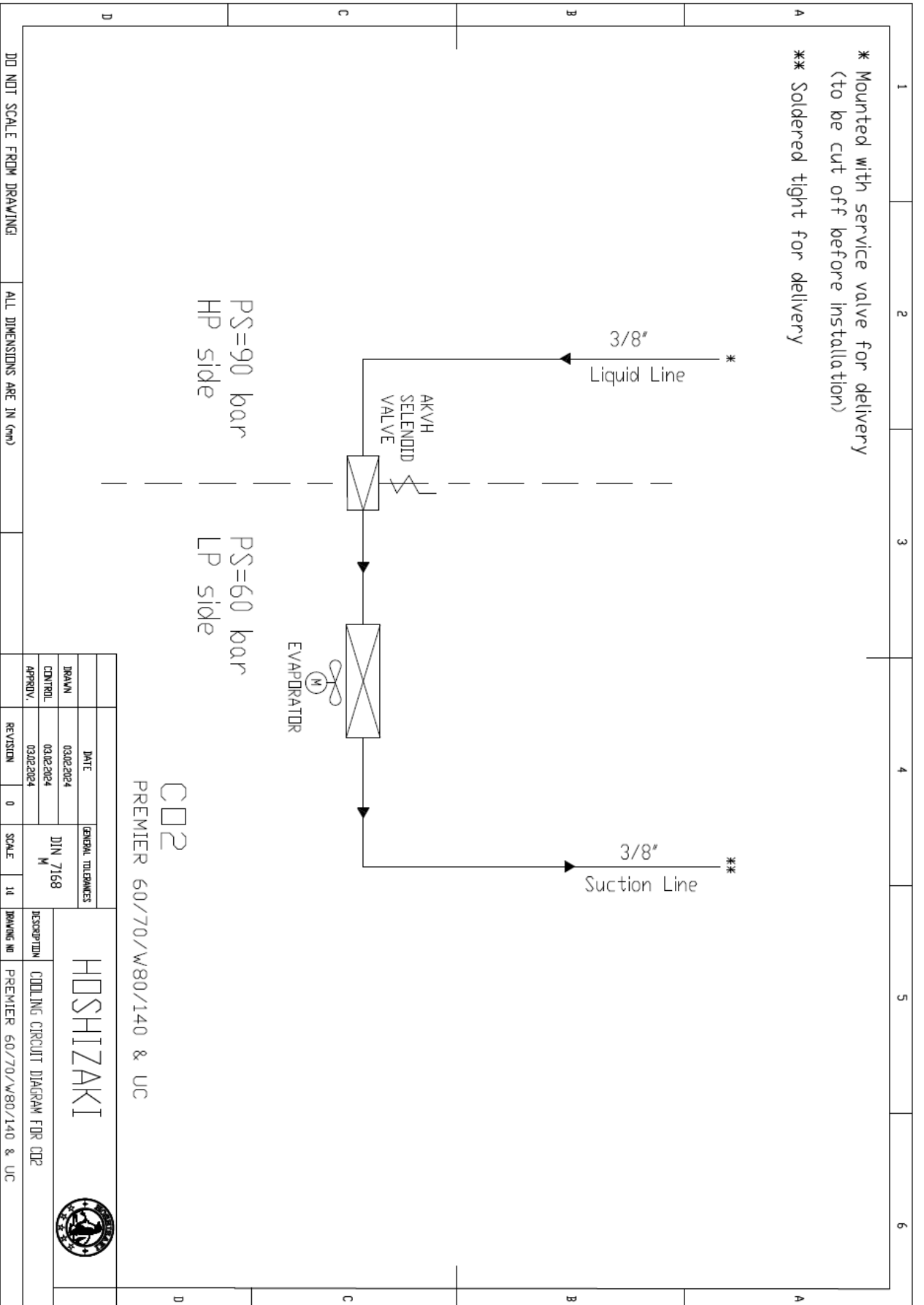



Todos los derechos reservados

Hoshizaki se reserva el derecho a cambiar cualquier característica e información de este manual.

Datos de contacto

Oficina central

Hoshizaki Europe B.V.

TEL.: +31 20 691

8499

Sales@hoshizaki.nl

<http://hoshizaki->

[europe.com/](http://hoshizaki-europe.com/)

Sucursales

Hoshizaki UK - Reino Unido, Irlanda

TEL.: +44 845 456 0585

uksales@hoshizaki.co.uk

Hoshizaki Deutschland - Alemania, Suiza, Austria

TEL.: +49 2154 92810, +49 5066 604612

info@hoshizaki.de

Hoshizaki BENELUX - Países Bajos, Bélgica, Luxemburgo

TEL.: +31 20 565 0420, +31 54 645 4252

sales@hoshizaki.nl

Hoshizaki France - Francia

TEL.: +33 1 48 63 93 80

info@hoshizaki.fr

Hoshizaki Iberia - España, Portugal

TEL.: +34 93 478 09 52

info@hoshizaki.es

Hoshizaki Middle East - Oriente Medio

TEL.: +971 48 876 612

sales@hoshizaki.ae

Hoshizaki Danmark – Dinamarca, Noruega, Suecia

TEL.: +45 8988 5350

salg@hoshizaki.dk

Hoshizaki Europe B.V – Resto de países de Europa y África

TEL.: +31 20 565 0420

sales@hoshizaki.nl

HOSHIZAKI

Premier Remote Cabinets



Afstandbediende modellen RU1 & CO2

HANDLEIDING VOOR BEDIENING, ONDERHOUD EN INSTALLATIE



Contactinformatie:

HOSHIZAKI EUROPE B.V.

Adres: Burgemeester Stramanweg 101 1101 AA Amsterdam, Nederland

Tel: +31 (0)20 691 84 99 - <http://hoshizaki-europe.com/>





Inhoudsopgave

Toepassing.....	171
Veiligheidsinformatie	172
Plaatsing.....	173
Elektrische aansluiting.....	175
Algemeen gebruik.....	176
Het product gebruiken (Evco-controller - RU1-model).....	177
Het product gebruiken (Danfoss-controller AK - CC55).....	178
Het product gebruiken (Carel MPXpro-controller).....	181
Het product bedienen (geen controller - NC-model).....	187
Problemen oplossen.....	187
Dooiwater	188
Sluitmechanisme deur.....	188
Stroomstoring	188
Reiniging	188
Deurpakkingen	189
Langdurige opslag	189
Service	189
Technische gegevens.....	190
Afmetingen	192
Afvoeren	199
Elektrisch Bedradingschema	200
Koelschema's	206



Bedankt dat u hebt gekozen voor een kwaliteitsproduct van Hoshizaki.

In deze handleiding vindt u informatie over de installatie, het gebruik en het onderhoud van uw nieuwe product.

Voordat onze producten de fabriek verlaten, ondergaan ze een volledige functie- en kwaliteitstest. Mocht u desondanks problemen met het product ervaren, neemt u dan contact op met uw lokale dealer.

De wereldwijde dochterondernemingen en dealers van Hoshizaki staan klaar om u te helpen.

Producten die door Hoshizaki worden geproduceerd, vallen onder verschillende garantievoorwaarden, afhankelijk van het land waarin het product wordt verkocht. Deze garantie is onderhevig aan een correct gebruik volgens de specificaties, wat onder meer inhoudt dat algemeen onderhoud en eventuele reparaties worden uitgevoerd door technici die zijn aangesteld door de dealer en die een algemene kennis hebben van het product.

Wijzigingen in de installatie en gebruik van het product anders dan gespecificeerd in deze handleiding kunnen van invloed zijn op de werking en duurzaamheid van het product.

De handleiding is geschreven op basis van onze huidige technische kennis. We werken deze informatie voortdurend bij en behouden ons het recht voor om technische wijzigingen door te voeren.

Toepassing

Het product is bestemd voor de opslag van levensmiddelen in niet-huishoudelijke omgevingen.

Het product is ontworpen voor opslag bij een constante temperatuur en kan niet worden gebruikt om warme/verse levensmiddelen af te koelen of in te vriezen.

Het product dient uitsluitend te worden gebruikt voor het doel waarvoor het specifiek is ontworpen. Elk ander gebruik kan ertoe leiden dat het in het product opgeslagen levensmiddel niet op de juiste temperatuur wordt bewaard of dat het product zelf beschadigd raakt.

Het product is niet geschikt voor het bewaren van bloedplasma, laboratoriummonsters, geneesmiddelen of vergelijkbare stoffen.

De fabrikant kan niet aansprakelijk of verantwoordelijk worden gesteld voor enige schade die ontstaat door ongeschikt, incorrect of onredelijk gebruik van het product.

Veiligheidsinformatie

Belangrijk

Beschrijving van de in deze handleiding gebruikte symbolen.



Waarschuwing Het niet opvolgen van deze instructies kan leiden tot ongelukken met persoonlijk letsel.



Belangrijk Als deze instructies niet worden opgevolgd, kan het product beschadigd raken of onbruikbaar worden.

Houd er rekening mee dat Hoshizaki voorzorgsmaatregelen heeft genomen om ervoor te zorgen dat de veiligheid van het product in orde is.

Lees de volgende veiligheidsinformatie zorgvuldig door.



Het is belangrijk dat iedereen die het product gaat gebruiken of installeren toegang heeft tot deze handleiding.



Dit apparaat is niet bedoeld voor gebruik door personen met verminderde fysieke, zintuiglijke of geestelijke capaciteiten, of een gebrek aan ervaring en kennis, tenzij dit gebeurt onder toezicht van of na het ontvangen van instructies met betrekking tot het gebruik door een persoon die verantwoordelijk is voor hun veiligheid.



Kinderen moeten worden begeleid om er zeker van te zijn dat zij niet met het apparaat gaan spelen.



Het apparaat kan onderdelen bevatten met scherpe randen in het compressorcompartiment en in het binnencompartiment.



Het apparaat mag niet op een steekwagen worden vervoerd vanwege gevaar van evenwichtsverlies, met persoonlijk letsel als gevolg.



Trek niet aan het netsnoer om het apparaat los te koppelen of tijdens verplaatsing van het apparaat.

Plaatsing

Controleer bij ontvangst van het product of het verpakkingsmateriaal beschadigd is.

Als het verpakkingsmateriaal beschadigd is, moet worden gecontroleerd of het product zelf ook beschadigd is. Als de schade aanzienlijk is, neemt u contact op met uw dealer.



Deze taak vereist minstens 2 personen. De bovenkant is het zwaarste deel van het product. Houd hier rekening mee bij het verwijderen van de transportpallet.



Door het zware gewicht van het product kan de vloer beschadigd of bekrast raken tijdens de verplaatsing van het product.



Correcte plaatsing draagt bij aan de meest effectieve werking.



Het product moet worden geplaatst in een droge en voldoende geventileerde ruimte.



Met het oog op een efficiënte werking mag de kast niet in direct zonlicht of op warmte uitstralende oppervlakken worden geplaatst. Het product is ontworpen om te werken bij een omgevingstemperatuur tussen +16°C en +40°C.



Vermijd plaatsing van het product in een chloor- of zuurhoudende omgeving (zwembad, enz.) vanwege het risico op corrosie.



Het product en delen van de binnenkant zijn voorzien van een beschermfolie, die voor gebruik moet worden verwijderd.

Reinig het product voor gebruik met een milde zeepoplossing.

De opstelplaats moet waterpas en horizontaal zijn.

Bij uitvoeringen met poten, gebruikt u de verstelbare poten om ervoor te zorgen dat het product waterpas en rechtop staat.

Bij uitvoeringen met zwenkwieken moeten de vergrendelingen van de twee voorste zwenkwieken zijn geactiveerd wanneer het product op zijn plek staat.

HOSHIZAKI

Premier Remote Cabinets



Er moet altijd 500 mm vrije ruimte boven het product zijn in verband met het onderhoud. Het product moet zo dicht mogelijk tegen de wand worden geplaatst.

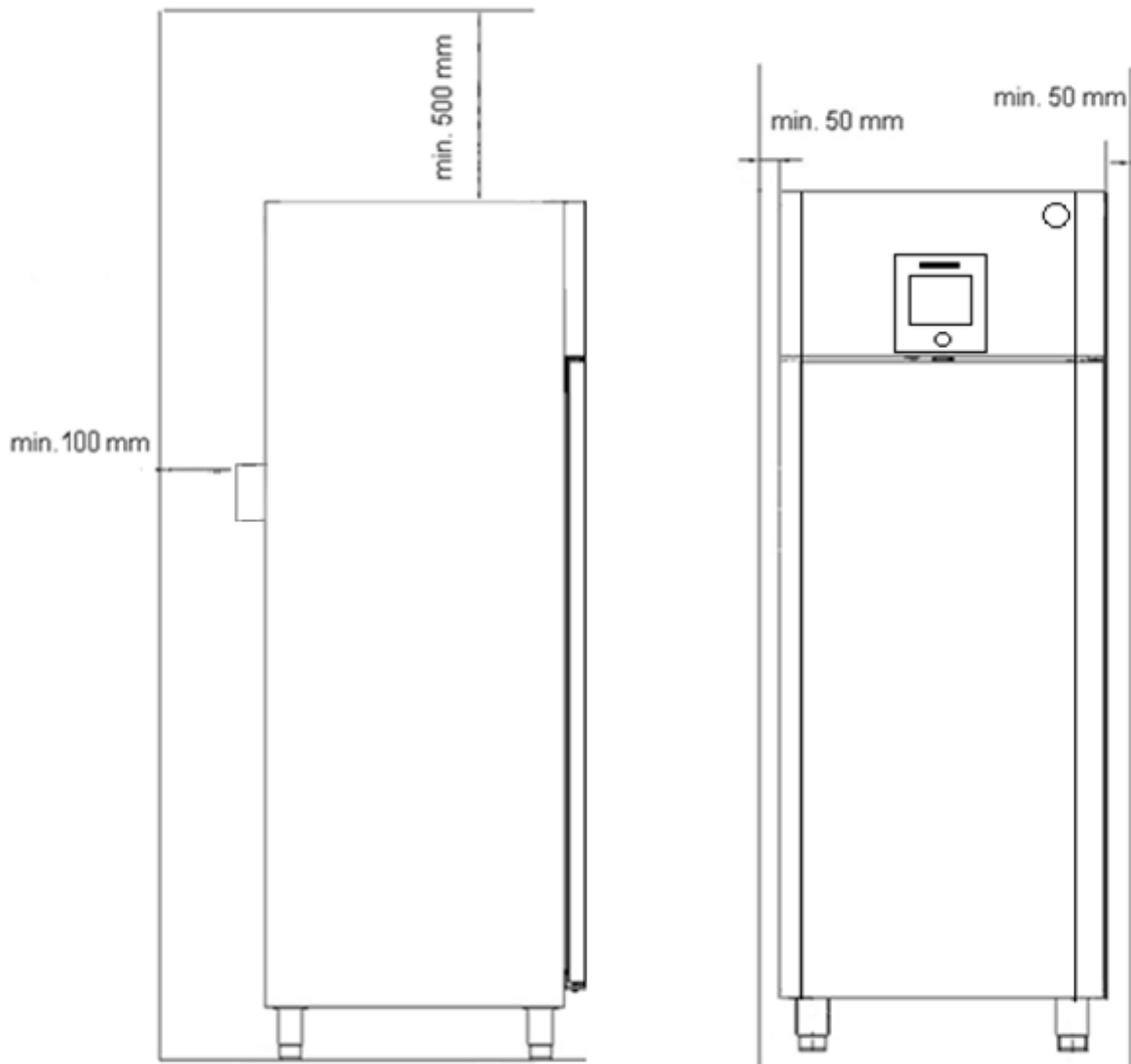

Elektrische aansluiting

Lees de onderstaande tekst zorgvuldig door voorafgaand aan de elektrische aansluiting.



Het product is bedoeld voor aansluiting op wisselstroom. De aansluitspanning (V) en frequentie (Hz) staan op het typeplaatje in de kast.



Gebruik nooit een verlengsnoer voor dit apparaat!

Als de wandcontactdoos zich op een grotere afstand bevindt dan de lengte van het meegeleverde netsnoer, vraag dan een elektricien om een wandcontactdoos binnen het bereik van het netsnoer te plaatsen.



Als het product defect is, **moet het worden onderzocht door een gekwalificeerde onderhoudstechnicus** die bekend is met de geïnstalleerde bedieningseenheid en ervaring heeft met het onderhoud van de CO2-kast.



In het algemeen dient het te worden onderzocht door het bedrijf dat het product heeft aangesloten.



Koppel de stroom altijd los als de stroomtoevoer wordt onderbroken, als er elektrische onderdelen worden verwijderd of geplaatst en voor reiniging of onderhoud van het product.



Gebruik het product niet zonder dat alle beschermende onderdelen zijn geïnstalleerd, om te voorkomen dat u werkende of draaiende onderdelen van de machine aanraakt.



Het product mag niet buiten worden gebruikt.

Alle door lokale instanties voorgeschreven aardingsvoorschriften dienen te worden nageleefd. De stekker en het stopcontact moeten vervolgens zorgen voor een goede aarding. Raadpleeg zo nodig een elektricien.



Zorg ervoor dat het product is uitgeschakeld bij het stopcontact of dat de C13-stekker is losgekoppeld, voordat er onderhoud wordt uitgevoerd aan elektrische onderdelen. Het is niet voldoende om het product uit te schakelen bij de controller.

Algemeen gebruik



Beschadig de onderdelen van het koelsysteem niet.



Als het product is voorzien van een herverdampingsbak onder de kast, is het belangrijk om er voordat u onderhouds-/reinigingswerkzaamheden uitvoert aan de bak of het verwarmingselement voor te zorgen dat de kast lang genoeg heeft uitgestaan, zodat het herverdampingselement is afgekoeld en er geen risico op brandwonden bestaat.



Gebruik geen elektrische apparaten in het product.



Voor een correcte en efficiënte luchtstroom in de kast is het van belang dat er zich geen voorwerpen buiten de aangegeven gebieden bevinden.



Alle te bewaren artikelen die niet zijn verpakt, moeten worden afgedekt om onnodige corrosie van de binnenkant van de kast te voorkomen.



Als de standaardparameters van de controller worden gewijzigd, kan dit ertoe leiden dat het product niet normaal functioneert en dat schadelijke temperaturen schade kunnen toebrengen aan de artikelen die in het product worden bewaard.



Maximale belasting van de plank: 40 kg



Bewaar geen explosieve stoffen zoals spuitbussen met ontvlambaar drijfgas in dit apparaat.



Plaats geen producten onder de onderste plankdrager of boven de bovenste laadlijnmarkering.

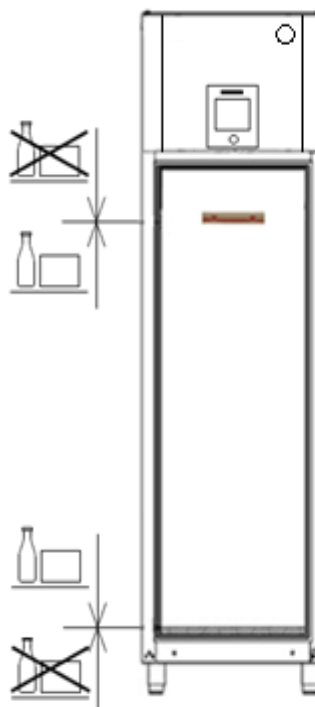

Do not store goods above the top loading mark

Do not store goods below the bottom grate

Het product gebruiken (Evco-controller - RU1-model)

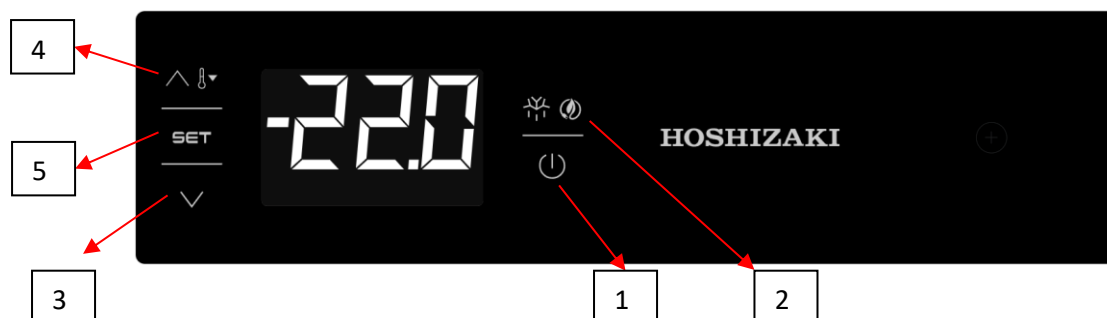

➤ FUNCTIES VAN VOORPANEEL

Om de toetsen op het voorpaneel te vergrendelen, houdt u de AUX-toets (3) en de Aan/Standby-toets (1) 2 seconden ingedrukt: als de toetsen vergrendeld zijn, wordt 'Loc' weergegeven op het scherm, als ze niet vergrendeld zijn, wordt 'UnL' weergegeven.

1) Als u de **AAN/STANDBY**-toets 4 seconden ingedrukt houdt, vergrendelt of ontgrendelt u het apparaat. (Aan/Uit)

2) **HANDMATIGE ONTDOOIING**; als u deze toets 4 seconden ingedrukt houdt, wordt het handmatige ontthooiingsproces gestart. Het handmatige ontthooiingsproces start niet als de superkoelfunctie is geactiveerd en de verdampertemperatuur niet geschikt is.

3) **OMLAAG**-toets: gebruik deze toets om in het menu naar beneden te bladeren of de waarde te verlagen; als u de toets 4 seconden ingedrukt houdt, wordt de superkoelfunctie geactiveerd. Wanneer er een superkoelfunctie is geactiveerd, kan de ingestelde temperatuur worden verlaagd; de tijd en temperatuur worden door de parameters bepaald. Wanneer er een superkoelfunctie is geactiveerd, zal het apparaat in geen geval ontthooien.

4) **OMHOOG**-toets: gebruik deze toets om in het menu naar boven te bladeren of de waarde te verhogen; als u deze toets 4 seconden ingedrukt houdt, wordt de functie voor het lage en hoge relatieve vochtigheidspercentage actief. (Op sommige modellen) Als de relatieve vochtigheid een laag percentage heeft, wordt 'rHL' weergegeven op het scherm. Heeft de relatieve vochtigheid een hoog percentage, dan wordt 'rHH' weergegeven. Deze functies worden 10 seconden op het scherm weergegeven. Als de vochtigheid niet kan worden gereguleerd, wordt "----" 1 seconde weergegeven op het scherm.

5) **SET**-toets: gebruik deze toets om aanpasbare waarden in te voeren of te veranderen.

➤ BEDRIJFSMODI

De mogelijke bedrijfsmodi worden hieronder weergegeven:

“**Aan**”-status: het apparaat is in bedrijf en wordt van stroom voorzien.

“**Standby**”-status: het apparaat is uitgeschakeld, maar wordt nog steeds van stroom voorzien.

“**Uit**”-status: om het apparaat uit te schakelen, verwijdert u de stekker uit het stopcontact of zet u de hoofdschakelaar uit.

Het product gebruiken (Danfoss-controller AK - CC55)

Opstarten:

Steek de stekker van het apparaat in het stopcontact.

Zorg ervoor dat de 2-polige hoofdschakelaar is ingeschakeld.

Uitleg van het display (AK-UI55):



Onderdelen van het display	Beschrijving
A	Licht op in geval van:  <ul style="list-style-type: none"> - Energieoptimalisatie (ECO) - Koelen - Ontdooien - Actieve ventilator
B	Gaat branden bij alarm.
C	Druk lang (3 seconden) op de alarmknop (relais wordt gereset) en de alarmcode wordt weergegeven.
D	Druk lang (3 seconden) om het informatiemenu "Inf" te openen. (Zie afbeelding "b") Pijl omhoog/Pijl omlaag/Pijl naar links: navigatie in het menu en het instellen van waarden.
E	Druk lang (3 seconden) om ontdooien te starten, "-d-" wordt weergegeven op het display. De actieve ontdooiing kan worden gestopt door lang te drukken.
F	SET: druk lang (3 seconden) om het menu "SET" te openen. Als de bediening is vergrendeld met een wachtwoord wordt "PS" weergegeven. Voer de code in. * Geeft de instelling voor een gekozen parameter weer / slaat een gewijzigde instelling op. Druk kort om de uitschakelgrens van de thermostaat in te voeren.

* De fabrieksinstelling van P89 is '0', deze stap wordt overgeslagen zonder invoerwaarden.

HOSHIZAKI

Premier Remote Cabinets



a- Lijst met parameters voor "SET"-knop

b – Lijst met parameters voor "Info"-knop

SET	←	SET button, 3 s: Configuration settings	
Set			
(PS) v	←	PS: Password (if any)	
cFg	SET →		r12 Main switch
v			o61 Application
r--			o03 MODBUS address
A--			r89 Food type
c--			r00 Cut-out temperature
d--			r15 Ther. sensor S4 %
n--			r61 Ther. sensor S4% night
F--			A36 Alarm sensor S4%
t--			o17 Display air S4%
h--			o30 Refrigerant type
o--			o20 Min. transmitter range
p--			o21 Max. transmitter range
q--			d01 Defrost method
u--			d03 Defrost interval
<			d10 Defrost sensor
(Return)			d04 Max. defrost time
			d02 Defrost stop temperature
			<
			(Return)

Menu groups
See also the following pages.

^	←	Info button, 3 s: Information for service use	
Inf			
StA	SET	See control state message	
App	SET	See selected application	
in	SET →		Al1 (PE)
out	SET →		Al2 **
buS	SET	MODBUS quality	Al3 **
SoF	SET	See SW version	Al4 **
<			Al5 **
(Return)			di1 **
			di2 **
			<
			(Return)

Output status
When you want info on a relay output, the dot will show whether the relay is activated (energized) for e.g.:

do4 = not activated
do.4 = activated

Read output status

Read input status

Foutmelding (alarmen)



In het geval van een foutsituatie brandt de alarm-led aan de voorzijde en wordt het alarmrelais geactiveerd (afhankelijk van de prioriteit). Als u 3 seconden op de alarmknop drukt, ziet u het alarmrapport in het display.

Raadpleeg de handleiding van de geselecteerde CO2-controller voor meer informatie. (Danfoss AK-CC55 Compact)

Code	Alarm text	Description
E01	Hardware failure	The controller has a hardware failure
E06	Clock lost time	Clock has lost valid time
E20	Pe Evap. pressure A - Sensor error	Sensor signal is out of range. Please check the sensor for correct operation
E24	S2 Gas outlet A - Sensor error	Sensor signal is out of range. Please check the sensor for correct operation
E25	S3 Air ON evap. A - Sensor error	Sensor signal is out of range. Please check the sensor for correct operation
E26	S4 Air OFF evap. A - Sensor error	Sensor signal is out of range. Please check the sensor for correct operation
E27	S5 Evaporator A - Sensor error	Sensor signal is out of range. Please check the sensor for correct operation
A01	High temperature alarm A	The alarm temperature has been above the max alarm limit for a longer time period than the set alarm delay.
A02	Low temperature alarm A	The alarm temperature has been below the min alarm limit for a longer time period than the set alarm delay.
A04	Door open alarm	The door has been open for a too long time
A05	Max defrost hold time exceeded	The controller has been waiting longer time than permitted after a co-ordinated defrost.
A11	Refrigerant not selected	The refrigerant has not been selected hence control can not be initiated
A15	DI alarm 1	Alarm signal from digital input signal
A16	DI alarm 2	Alarm signal from digital input signal
A45	Main switch set OFF	The controller main switch has been set to either Stop or Manual control. Alternatively a digital input set up for "main switch" function, has stopped control
A59	Case in cleaning mode	A case cleaning operation has been started on a case
AA2	CO ₂ leak detected	CO ₂ is leaking from the refrigeration system
AA3	Refrigerant leak detected	Refrigerant is leaking from the refrigeration system
a04	Wrong IO configuration	Inputs and outputs have not been configured correctly

Het product gebruiken (Carel MPXpro-controller)

Opstarten

Steek de stekker van het apparaat in het stopcontact.

De kast-controller is bij levering ingeschakeld (standaardinstelling). Dit betekent dat de controller begint met regelen zodra de voeding wordt aangesloten en de hoofdschakelaar aan staat.

De kast in-/uitschakelen

Als u de kast in/uit wilt schakelen moet u de 2-polige hoofdschakelaar gebruiken die zich aan de linkerkant van het hoofdbedieningspaneel in "het compressorcompartiment" bevindt.

Het display



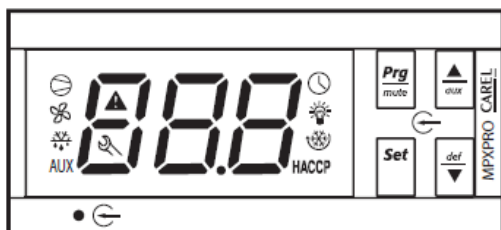

Indeling van het display/uitleg:



Het bovenstaande display heeft een uitlezing van drie cijfers.

Binnen het uitleesgebied bevinden zich verschillende leds. Deze leds geven de volgende indicaties.

In het algemeen = Als een led knippert, is de activering vertraagd of beperkt.

-  = Koelen aan (als deze led brandt, is koelen ingeschakeld)
-  = Binnenventilator draait (als deze led brandt, is de interne ventilator van de verdamper ingeschakeld)
-  = Ontdooien aan (als deze led brandt, is er een ontdooicyclus actief)
-  = Als de led knippert, is dit een indicatie dat de deur open is of dat er een alarm actief is of een fout is opgetreden.

HACCP = Als deze led brandt, is er een HACCP-alarm actief. Als deze led knippert, is er een opgeslagen HACCP-alarm.



Knoppen:

De 4 knoppen aan de rechterkant van het display worden gebruikt om verschillende parameters weer te geven en aan te passen. Deze knoppen kunnen afzonderlijk of in combinatie worden ingedrukt om de controller in werking te stellen.

De onderstaande instellingen zijn de enige instellingen die door de eindgebruiker moeten worden gewijzigd. De eindgebruiker mag nooit parameters wijzigen die niet hier worden verklaard. Alle andere instellingen moeten door een ervaren technicus worden uitgevoerd.

GEBRUIKERSINSTELLINGEN

De insteltemperatuur van de kast aanpassen



: omhoog



: omlaag



:Set



: Prg/mute

- Houd tijdens normaal bedrijf Set ingedrukt totdat het display begint te knipperen. De insteltemperatuur van de kast kan worden aangepast met behulp van omhoog en omlaag .
- Wanneer het instelpunt is aangepast aan de gewenste temperatuur, drukt u Set kort in om de nieuwe waarde op te slaan en terug te keren naar de normale werking.

Een handmatige ontdooiing uitvoeren

- Houd tijdens normaal bedrijf def meer dan 5 seconden ingedrukt om een handmatige ontdooiing uit te voeren als de temperatuur van de verdampersonde koud genoeg is.
- Wanneer het ontdooisymbool  oplicht, geeft dit aan dat er een ontdooiing actief is.
- Als def meer dan 5 seconden wordt ingedrukt tijdens een ontdooicyclus, wordt de ontdooiing gedeactiveerd.

Akoestische alarmen dempen

- Wanneer de controller in de alarmmodus staat, hoort u een akoestisch signaal. Het alarm kan worden gedempt door op Prg/mute te drukken.

HOSHIZAKI

Premier Remote Cabinets



De alarmlimieten voor de temperatuur instellen

- Houd tijdens normaal bedrijf Prg/mute meer dan 5 seconden ingedrukt om de lijst met parameters te openen. Het display geeft /c1 weer
- Druk op Prg/mute . De eerste categorie parameters, “Pro”, wordt weergegeven
- Druk op UP totdat u de categorie “ALn” bereikt, zoals aangegeven door het oplichtende pictogram  op het display.
- Druk op Set parameter AA wordt weergegeven.
- Druk op UP tot u A1 bereikt.
- Druk op Set om aan te passen of voor AL (temperatuurgrens voor **Alarm Low**) en AH (temperatuurgrens voor **Alarm High**) de instellingen (0 = ten opzichte van de instelpunten van de kasttemperatuur) of (1 = absoluut) moeten zijn. Standaardinstelling = 1
- Druk op Set om de gekozen instelling op te slaan en terug te keren naar A1.
- Druk op UP tot u AL bereikt (temperatuurgrens voor **Alarm Low**).
- Druk op Set om AL aan te passen met behulp van omhoog en omlaag (instelbaar tussen -50 en +50). Standaardinstelling = -50°C
- Druk op Set om de gekozen instelling op te slaan en terug te keren naar AL.
- Druk op UP tot u AH (temperatuurgrens voor **Alarm High**) bereikt.
- Druk op Set om AH aan te passen met behulp van omhoog en omlaag (instelbaar tussen -50 en +50). Standaardinstelling = +50°C
- Druk op Set om de gekozen instelling op te slaan en terug te keren naar AH.
- Druk op UP tot u Ad (**Alarm Delay time**, vertragingstijd voor AL en AH) bereikt.
- Druk op Set om Ad aan te passen met behulp van omhoog en omlaag (instelbaar tussen 0 en 240 minuten). Standaardinstelling = 120 minuten.
- Druk op Set om de gekozen instelling op te slaan en terug te keren naar Ad.
- Houd Prg/mute meer dan 5 seconden ingedrukt om wijzigingen op te slaan en keer dan terug naar het hoofdmenu.

Bij het instellen van temperatuuralarmgrenzen en alarmvertragingstijden die geschikt zijn voor een koelkast of vrieskast, kunt u de onderstaande alarminstellingen als voorbeeld gebruiken:

	Instelpunt	A1	AL	AH	Ad
Koelkast	+5 °C	1	+1 °C	+8 °C	120 min.
Vrieskast	-18 °C	1	-50 °C	-15 °C	120 min.

HOSHIZAKI

Premier Remote Cabinets



Het alarmlogboek weergeven

- Druk op Prg/mute en Set en houd 5 seconden ingedrukt.
- Voer het wachtwoord in: 44.
- Druk op Set om een submenu te openen waarin OMHOOG en OMLAAG worden gebruikt om door de verschillende alarmen te bladeren: HS0 t/m HS9.
- Selecteer een alarm en druk op Set om de code, het uur, de minuten en de duur weer te geven.
- Vanaf elke subparameter kunt u op Prg/mute drukken om de controller terug te laten keren naar de hoofdparameter "HSx".
- Druk gedurende 5 seconden op Prg/mute om terug te keren naar

de standaardweergave. Voorbeeld:

'HI' -> 'h17' -> 'm23' -> '65'

geeft aan dat het alarm "HI" (alarm voor hoge temperatuur) om 17:23 uur is geactiveerd en 65 minuten heeft geduurd.

HACCP-ALARMEN

Er worden twee soorten HACCP-gebeurtenissen beheerd:

- type HA-alarmen, hoge temperatuur tijdens het gebruik;
- type HF-alarmen, hoge temperatuur na stroomuitval (black-out).

Wanneer een alarm wordt geregistreerd, knippert de HACCP-led, geeft het display de alarmcode weer, wordt het alarm opgeslagen en worden het alarmrelais en de zoemer geactiveerd.

HA- en HF-alarmen weergeven

- Druk gelijktijdig op Prg/mute en OMLAAG .
- Blader door de lijst met alarmen door op OMHOOG en OMLAAG te drukken.
- Druk op Set om het gewenste alarm te selecteren.
- Gebruik OMHOOG of OMLAAG om de beschrijving van het alarm te zien: jaar, maand, dag, uren, minuten en de duur in minuten van het geselecteerde alarm.
- Druk opnieuw op Prg/mute om terug te gaan naar de vorige lijst.

Bovendien zijn in het menu voor het HACCP-alarm de volgende handelingen mogelijk:



Een HACCP-alarm verwijderen

- Druk gedurende 5 seconden op Set en OMLAAG terwijl de lijst met alarmen wordt weergegeven.

Hierdoor gaat de HACCP knipperen, het display geeft het bericht rES weer en de bewaking van de HACCP-alarmen wordt opnieuw geïnitieerd.

HACCP-alarmen uit het volledige geheugen wissen

- Druk gedurende 5 seconden op Set en OMHOOG en OMLAAG .

Hierdoor wordt het bericht rES weergegeven, alle alarmen worden uit het geheugen gewist en de bewaking van de HACCP-alarmen wordt opnieuw geïnitieerd.

Als u de HACCP-alarmen wilt gebruiken, is het noodzakelijk dat de realtime-klok door het installerende bedrijf wordt aangepast voordat de kast aan de eindgebruiker wordt overgedragen. Deze aanpassingen worden beschermd door een toegangscode en kunnen daarom niet door de eindgebruiker worden uitgevoerd.

Kastverlichting

Op alle kasten is de kastverlichting aan de buitenkant van de kast geplaatst, boven de deur. Deze verlichting wordt bediend door de hoofd-controller en de manier waarop deze werkt kan dus niet worden gewijzigd.

Wanneer de deur van de kast wordt geopend, wordt de verlichting boven de deur ingeschakeld. Wanneer u de deur sluit, wordt de kastverlichting boven de deur uitgeschakeld.

Fouten en alarmen

Display code	Cause of the alarm	Icon flash on display	Alarm relay	Buzzer	Reset	Compressor	Defrost	Evaporator fans	Continuous cycle	Signalled on tLAN	Network solenoid valve
rE	Control probe fault		ON	ON	automatic	duty setting(c4)	unchanged	unchanged	unchanged	√	-
E1	Probe S1 fault		OFF	OFF	automatic	duty setting(c4)	unchanged	unchanged	unchanged	√	-
E2	Probe S2 fault		OFF	OFF	automatic	unchanged	unchanged	unchanged	unchanged	√	-
E3	Probe S3 fault		OFF	OFF	automatic	unchanged	unchanged	unchanged	unchanged	√	-
E4	Probe S4 fault		OFF	OFF	automatic	unchanged	unchanged	unchanged	unchanged	√	-
E5	Probe S5 fault		OFF	OFF	automatic	unchanged	unchanged	unchanged	unchanged	√	-
E6	Probe S6 fault		OFF	OFF	automatic	unchanged	unchanged	unchanged	unchanged	√	-
E7	Probe S7 fault		OFF	OFF	automatic	unchanged	unchanged	unchanged	unchanged	√	-
E8	Serial probe S8 not updated		OFF	OFF	automatic	duty setting(c4)	unchanged	unchanged	unchanged	√	-
E9	Serial probe S9 not updated		OFF	OFF	automatic	duty setting(c4)	unchanged	unchanged	unchanged	√	-
E10	Serial probe S10 not updated		OFF	OFF	automatic	duty setting(c4)	unchanged	unchanged	unchanged	√	-
E11	Serial probe S11 not updated		OFF	OFF	automatic	duty setting(c4)	unchanged	unchanged	unchanged	√	-
LO	Low temperature alarm		ON	ON	automatic	unchanged	unchanged	unchanged	unchanged	√	-
HI	High temperature alarm		ON	ON	automatic	unchanged	unchanged	unchanged	unchanged	√	-
LO2	Low temperature alarm		ON	ON	automatic	unchanged	unchanged	unchanged	unchanged	√	-
HI2	High temperature alarm		ON	ON	automatic	unchanged	unchanged	unchanged	unchanged	√	-
IA	Immediate alarm from external contact		ON	ON	automatic	duty setting(A6)	unchanged	unchanged	unchanged	√	-
dA	Delayed alarm from external contact		ON	ON	automatic	duty setting(A6) if A7≠0	unchanged	unchanged	unchanged	√	-
dor	Door open for too long alarm		ON	ON	automatic	unchanged	unchanged	unchanged	unchanged	√	-
Etc	Real time clock fault		OFF	OFF	automatic	unchanged	unchanged	unchanged	unchanged	√	-
LSH	Low superheat alarm		OFF	OFF	automatic	OFF	unchanged	unchanged	unchanged	√	√
LSA	Low suction temperature alarm		OFF	OFF	automatic / manual	OFF (paragraph 6.10)	unchanged	unchanged	unchanged	√	√
MOP	Maximum evaporation pressure alarm		OFF	OFF	automatic	OFF	unchanged	unchanged	unchanged	√	√
LOP	Low evaporation temperature alarm		OFF	OFF	automatic	unchanged	unchanged	unchanged	unchanged	√	√
bLo	Valve blocked alarm		OFF	OFF	manual/ disabled with P14=0	unchanged	unchanged	unchanged	unchanged	√	-
Edc	Communication error with stepper driver		ON	ON	automatic	unchanged	unchanged	unchanged	unchanged	√	-
EFS	Stepper motor broken/not connected		ON	ON	automatic	unchanged	unchanged	unchanged	unchanged	√	-
EE	Flash unit parameter error		OFF	OFF	automatic	OFF	not performed	OFF	not performed	√	-
EF	EEPROM operating parameter error		OFF	OFF	automatic	OFF	not performed	OFF	not performed	√	-
HA	Type HA HACCP alarm	HACCP	OFF	OFF	manual	unchanged	unchanged	unchanged	unchanged	√	-
HF	Type HF HACCP alarm	HACCP	OFF	OFF	manual	unchanged	unchanged	unchanged	unchanged	√	-
MA	Communication error with Master (only on Slave)		ON	ON	automatic	unchanged	unchanged	unchanged	unchanged	-	-
u1...u5	Communication error with Slave (only on Master)		ON	ON	automatic	unchanged	unchanged	unchanged	unchanged	-	-
n1...n5	Alarm on unit 1 to 5 in the network		ON	ON	automatic	unchanged	unchanged	unchanged	unchanged	-	-
up1...up5	Upload procedure with errors on unit 1 to 5		OFF	OFF	-	unchanged	unchanged	unchanged	unchanged	-	-
GPE	Error in custom gas parameters		ON	ON	automatic	OFF	not performed	OFF	not performed	√	-



Raadpleeg de handleiding van de geselecteerde CO2-controller voor meer informatie. (Carel MPX PRO)



Het product bedienen (geen controller - NC-model)



Raadpleeg de handleiding bij de geïnstalleerde controller.

Problemen oplossen

Lawaai:

- Als er abnormaal lawaai optreedt, vraag dan om onderhoudshulp.
- De bedrijfsgeluiden van de interne ventilator zijn normaal.
- Als metalen plaatdelen, voorpanelen of panelen voor het compartiment lawaai maken, kan het zijn dat deze openstaan. Sluit de panelen.

IJsvorming binnen compartiment:

- Luchtvochtigheid omgeving te hoog.
- De deur wordt te vaak geopend.
- De deur is lang open blijven staan.
- Beschadigde deuropakking. Controleer grondig op schade.

Slechte koeling:

- Omgevingstemperatuur te hoog.
- De deur wordt te vaak geopend en/of staat te lang open.
- De deur is open blijven staan.
- Beschadigde deuropakking.
- Instelling temperatuur is te hoog.
- Product is te vol geladen met voedingsmiddelen - luchtinlaat/-uitlaat geblokkeerd.
- Warme of hete voedingsmiddelen in het product.
- Ontdooicyclus actief. De temperatuur in de behuizing kan tijdens de ontdooicyclus tijdelijk stijgen, maar dit zal niet van invloed zijn op de voedingsmiddelen in het apparaat. De led voor ontdooien brandt.

Sommige levensmiddelen zijn bevroren:

- Product is te vol geladen met voedingsmiddelen - luchtinlaat/-uitlaat geblokkeerd.
- Instelpunt voor temperatuur is te laag.
- De ventilator van de verdamper kan defect zijn.

Condensatie rond de deur:

- Luchtvochtigheid omgeving te hoog.
- De deur zit niet stevig dicht.
- Beschadigde deuropakking.
- De parameter voor de deurframeverwarming is niet correct aangepast.

Te hoog energieverbruik:

- Omgevingstemperatuur te hoog.
- De deur wordt te vaak geopend en/of staat te lang open.
- De deur is open blijven staan.
- Beschadigde deuropakking.
- Instelpunt voor temperatuur is te laag.
- Product is te vol geladen met voedingsmiddelen - luchtinlaat/-uitlaat geblokkeerd.
- Warme of hete levensmiddelen zijn in het product geplaatst.
- Het product is in direct zonlicht geplaatst of in de buurt van warmte uitstralende oppervlakken.
- De standaardinstellingen zijn gewijzigd.



Dooiwater

Tijdens het ontdooien produceert het product water dat in het herverdampingsstelsel wordt geleid door een vacuüm kunststof deel bovenaan de kast (voor Premier-koel-/vriestkasten)

Het water wordt opnieuw verdampt met een elektrisch verwarmingselement en een ventilator. In zeldzame gevallen zorgt het gebruikspatroon van de kast voor meer water dan het product opnieuw kan verdampen, waardoor er een overloop van water kan optreden. Als dit gebeurt kan het elektrische verwarmingselement worden ingesteld om 100% te draaien of kan het worden losgekoppeld om in plaats daarvan een waterafvoer op de achterkant aan te sluiten. Deze aanpassingen moeten door een ervaren onderhoudstechnicus worden uitgevoerd.

Sluitmechanisme deur

De deur is uitgerust met een zelfsluitend systeem. Als de deur minder dan 90° wordt geopend, zal deze vanzelf sluiten. Als de deur meer dan 90° wordt geopend, blijft deze openstaan.

De deur kan met het voetpedaal worden geopend. Hierdoor houdt u beide handen vrij wanneer u voedingsmiddelen in de kast plaatst.

Stroomstoring

In het geval van een stroomstoring onthoudt de controller de instelling van de temperatuur en herstart het product zodra de stroom wordt hersteld.

Reiniging

Als het product niet voldoende wordt gereinigd, zal het niet optimaal werken of uiteindelijk defect raken.



Voor het reinigen moet het product altijd worden losgekoppeld.



Spoel het product niet met water, gebruik geen waterstraal of stoomslang; dit kan kortsluiting in het elektrische systeem veroorzaken.



Reinigingsmiddelen die chloor of chloorverbindingen en andere corrosieve middelen bevatten, **mogen niet worden gebruikt**, aangezien deze corrosie op de roestvrijstalen panelen van de kast en de verdamper kunnen veroorzaken.



Het product moet vrij van stof en vuil worden gehouden. Dit kan het best worden gedaan met een stofzuiger en een borstel.



Voor het externe onderhoud – gebruik polijstmiddel voor roestvrij staal.



Het product moet periodiek van binnen worden gereinigd met een milde zeepoplossing en weer grondig worden gecontroleerd voordat het opnieuw in werking wordt gesteld.

Deurpakkingen

Dit hoofdstuk gaat over het belang van een goed functionerende deurpakking.

Pakkingen vormen een belangrijk onderdeel van een koelkast/vrieskast. Pakkingen met verminderde functionaliteit verminderen de dichtheid van de kast. Verminderde dichtheid kan leiden tot verhoogde vochtigheid, interne ijsvorming, een verijdsde verdamper (waardoor het koelvermogen afneemt) en in het ergste geval een verminderde levensduur van de kast.



Daarom is het belangrijk om de staat van de pakking in de gaten te houden. Regelmatige inspectie wordt aanbevolen.

De pakking moet regelmatig worden gereinigd met een milde zeepoplossing. Als een pakking moet worden vervangen, neemt u contact op met uw leverancier.

Langdurige opslag

Als het product uit bedrijf wordt genomen en moet worden voorbereid op langdurige opslag, reinig dan het binnencompartiment, de deur en de deurpakking grondig met een warm sopje en een vochtige doek. Eventuele resten van voedsel kunnen gaan schimmelen.

Service

Als de koeling uitvalt, controleer dan eerst of de eenheid onbedoeld is losgekoppeld of uitgeschakeld bij het stopcontact of dat er een zekering is doorgebrand.

Indien het niet mogelijk is de oorzaak van de storing in de koeling te achterhalen, neem dan contact op met de installateur van de eenheid.

Wanneer u contact opneemt met HOSHIZAKI of de installateur, geef ons dan de naam en het serienummer aan de binnenkant van de kast door. Deze informatie staat vermeld op het typeplaatje.

HOSHIZAKI

Premier Remote Cabinets



Technische gegevens

Plaatsing van etiket:

PRODUCT DESCRIPTION LABEL																														
1 Product Number		<table border="1" style="width: 100%; border-collapse: collapse;"> <tr> <td style="width: 80%;">PRODUCT NUMBER</td> <td style="width: 20%; text-align: center;">1</td> </tr> <tr> <td colspan="2" style="text-align: center;"> </td> </tr> <tr> <td>PRODUCT DESCRIPTION</td> <td style="text-align: center;">2</td> </tr> <tr> <td>MODEL</td> <td style="text-align: center;">3</td> </tr> <tr> <td>REFRIGERANT</td> <td style="text-align: center;">4</td> </tr> <tr> <td>CO2 EQUIVALENT</td> <td style="text-align: center;">5</td> </tr> <tr> <td>IP PROTECTION</td> <td style="text-align: center;">6</td> </tr> <tr> <td>CLIMATE CLASS</td> <td style="text-align: center;">7</td> </tr> <tr> <td>PRODUCTION DATE</td> <td style="text-align: center;">8</td> </tr> <tr> <td>TOTAL POWER / CURRENT / LAMP POWER</td> <td style="text-align: center;">9</td> </tr> <tr> <td>VOLTAGE - FREQUENCY</td> <td style="text-align: center;">10</td> </tr> <tr> <td>HEATING ELEMENT</td> <td style="text-align: center;">11</td> </tr> <tr> <td>SYSTEM PRESSURE</td> <td style="text-align: center;">12</td> </tr> <tr> <td>BLOWING AGENT</td> <td style="text-align: center;">13</td> </tr> </table>	PRODUCT NUMBER	1			PRODUCT DESCRIPTION	2	MODEL	3	REFRIGERANT	4	CO2 EQUIVALENT	5	IP PROTECTION	6	CLIMATE CLASS	7	PRODUCTION DATE	8	TOTAL POWER / CURRENT / LAMP POWER	9	VOLTAGE - FREQUENCY	10	HEATING ELEMENT	11	SYSTEM PRESSURE	12	BLOWING AGENT	13
PRODUCT NUMBER		1																												
PRODUCT DESCRIPTION		2																												
MODEL		3																												
REFRIGERANT		4																												
CO2 EQUIVALENT		5																												
IP PROTECTION		6																												
CLIMATE CLASS		7																												
PRODUCTION DATE		8																												
TOTAL POWER / CURRENT / LAMP POWER		9																												
VOLTAGE - FREQUENCY		10																												
HEATING ELEMENT		11																												
SYSTEM PRESSURE		12																												
BLOWING AGENT	13																													
2 Product Description																														
3 Model																														
4 Refrigerant (GWP)																														
5 CO2 Equivalent																														
6 IP Protection																														
7 Climate Class																														
8 Production Date																														
9 Total power / Current / Lamp power																														
10 Voltage - Frequency																														
11 Heating Element																														
12 System Pressure																														
13 Blowing Agent																														
14 Serial Number		<p>S/N: 14</p> <p>HOSHIZAKI EUROPE B.V. Burgemeester Stramanweg 101 1101 AA Amsterdam, The Netherlands</p> <div style="display: flex; justify-content: space-around; align-items: center;"> </div>																												

Trade mark			HOSHIZAKI			
Model name			PREMIER U 70	PREMIER U 140	PREMIER U 80	PREMIER U 60
Bedoeld gebruik			Storage	Storage	Storage	Storage
Gekoelde bedrijfstemperatuur			X	X	X	X
Bevoren bedrijfstemperatuur			X	X	X	X
Multifunctionele kast						
Verticale kast			X	X	X	X
Werkbank						
Parameter	Symbol	Unit				
Brutovolume	VnT	L	700	1400	700	480
Klimaatklasse			CC5	CC5	CC5	CC5
Voedingsspanning/frequentie	V / Hz		230 - 50	230 - 50	230 - 50	230 - 50
Koelmiddel (CO2-kast)			CO2	CO2	CO2	CO2
Koelmiddel (RU-1-kast)			HFC / HFO Refrigerant*	HFC / HFO Refrigerant*	HFC / HFO Refrigerant*	HFC / HFO Refrigerant*
Contactgegevens:	<p>HOSHIZAKI EUROPE B.V. Address: Burgemeester Stramanweg 101 1101 AA Amsterdam, The Netherlands Tel: +31 (0)20 691 84 99 - http://hoshizaki.europe.com/</p>					

* Koelmiddelen die compatibel zijn met de doorlaat voor de expansieklep (R449A, R448A, R45A, enz. Controleer het gegevensblad voor het gebruik van de doorlaat)

HOSHIZAKI

Premier Remote Cabinets



Trade mark			HOSHIZAKI		
Model name			BAKER U 950	BAKER GA 950	PREMIER SF 950
Bedoeld gebruik			Storage	Cooling /Freezing / Storage / Proving	Cooling / Shock Freezing
Gekoelde bedrijfstemperatuur			X	X	X
Bevroren bedrijfstemperatuur			X	X	X
Multifunctionele kast				X	X
Verticale kast			X	X	X
Werkbank					
Parameter	Symbol	Unit			
Brutovolume	VnT	L	1000	950	950
Klimaatklasse			CC5	CC5	CC5
Voedingsspanning/frequentie	V / Hz		230 - 50	230 – 50	230 – 50
Koelmiddel (RU-1-kast)			HFC / HFO Refrigerant*	HFC / HFO Refrigerant*	HFC / HFO Refrigerant*
Contactgegevens:	HOSHIZAKI EUROPE B.V. Address: Burgemeester Stramanweg 101 1101 AA Amsterdam, The Netherlands Tel: +31 (0)20 691 84 99 - http://hoshizaki.europe.com/				

* Koelmiddelen die compatibel zijn met de doorlaat voor de expansieklep (R449A, R448A, R45A, enz. Controleer het gegevensblad voor het gebruik van de doorlaat)

HOSHIZAKI

Premier Remote Cabinets



Afmetingen

PREMIER U 70

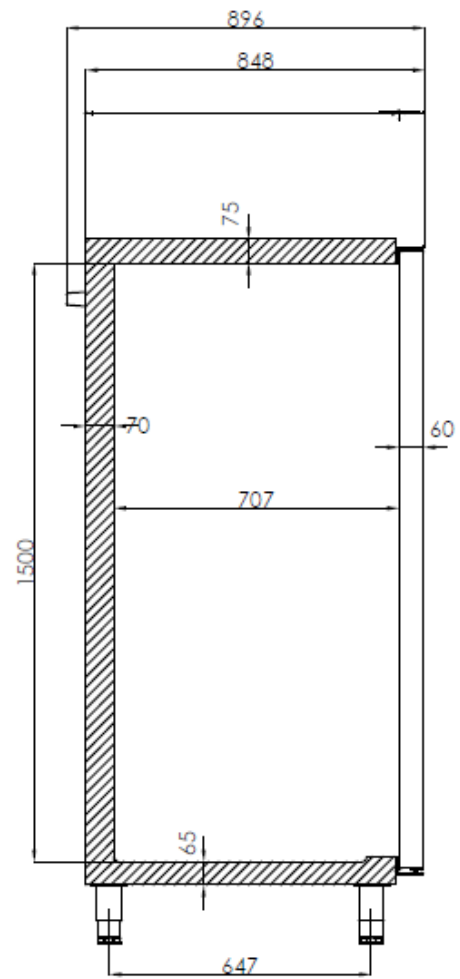
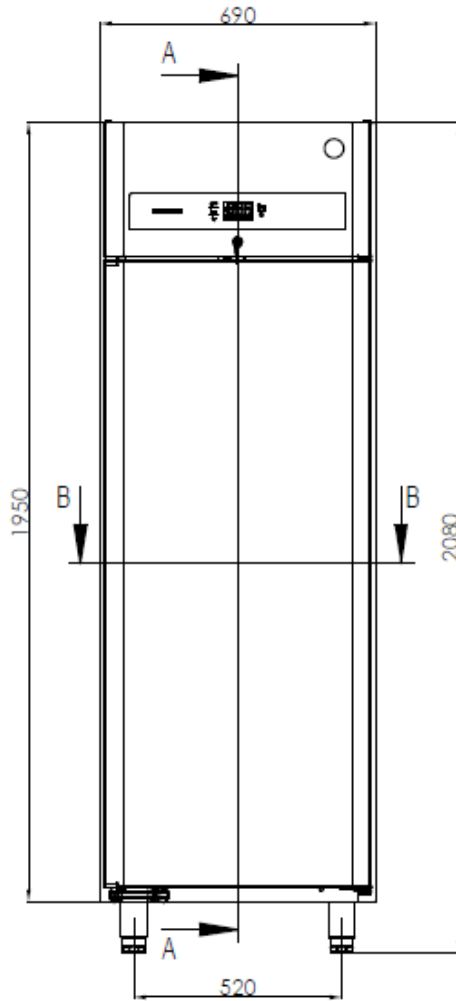

A-A

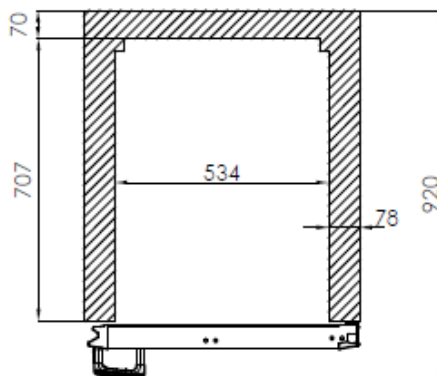

B-B

HOSHIZAKI

Premier Remote Cabinets



PREMIER U 60

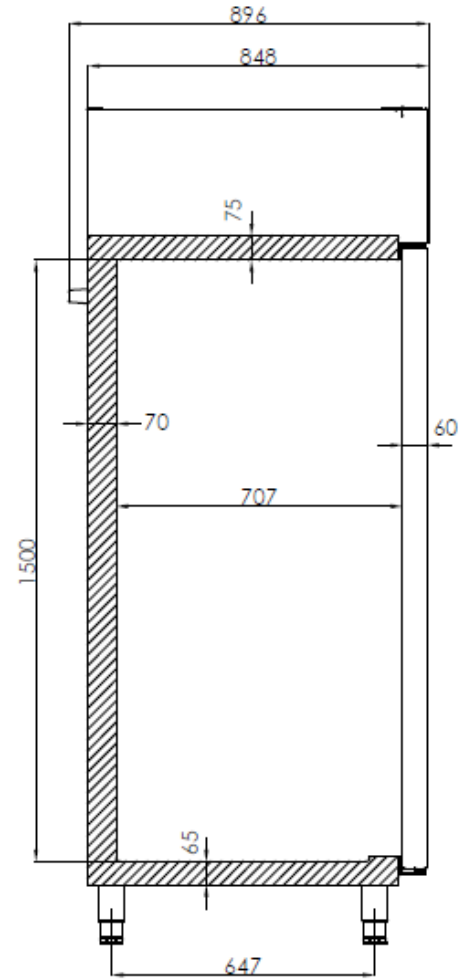
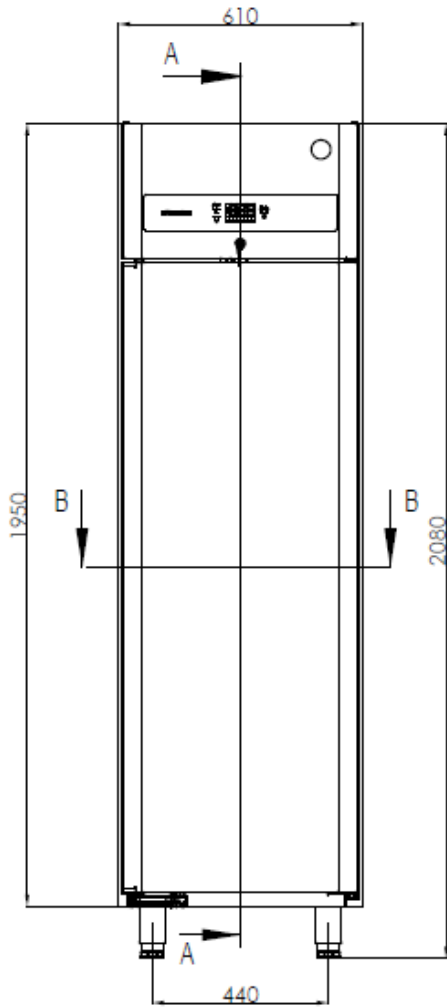

A-A

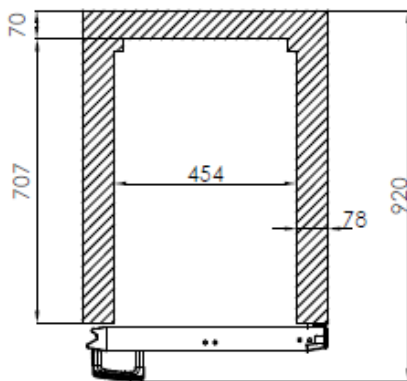

B-B

HOSHIZAKI

Premier Remote Cabinets



PREMIER U 80

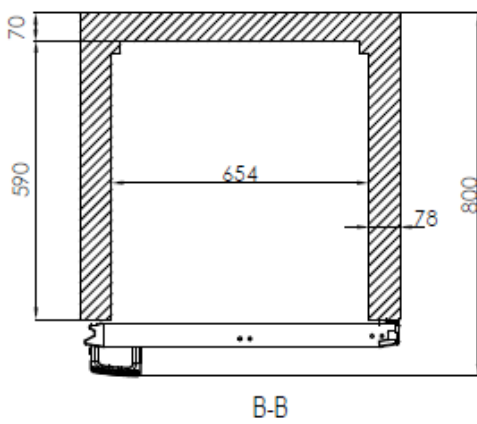
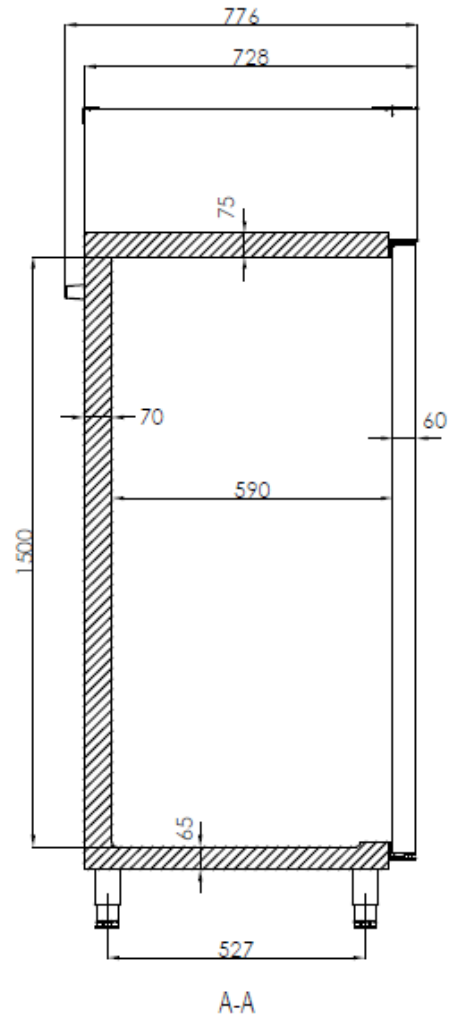
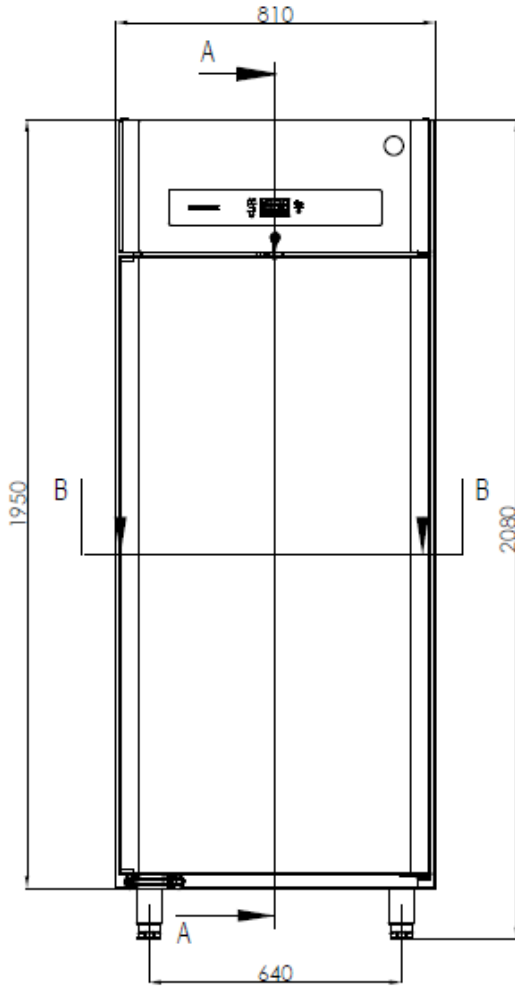

HOSHIZAKI

Premier Remote Cabinets



PREMIER U 140

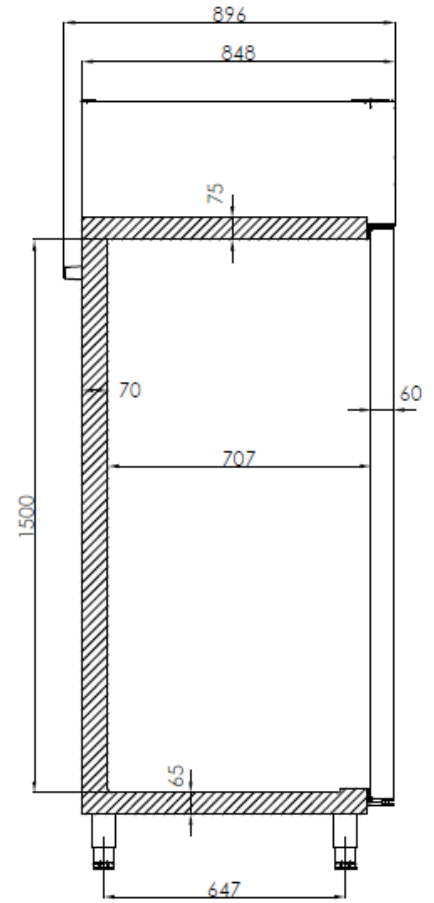
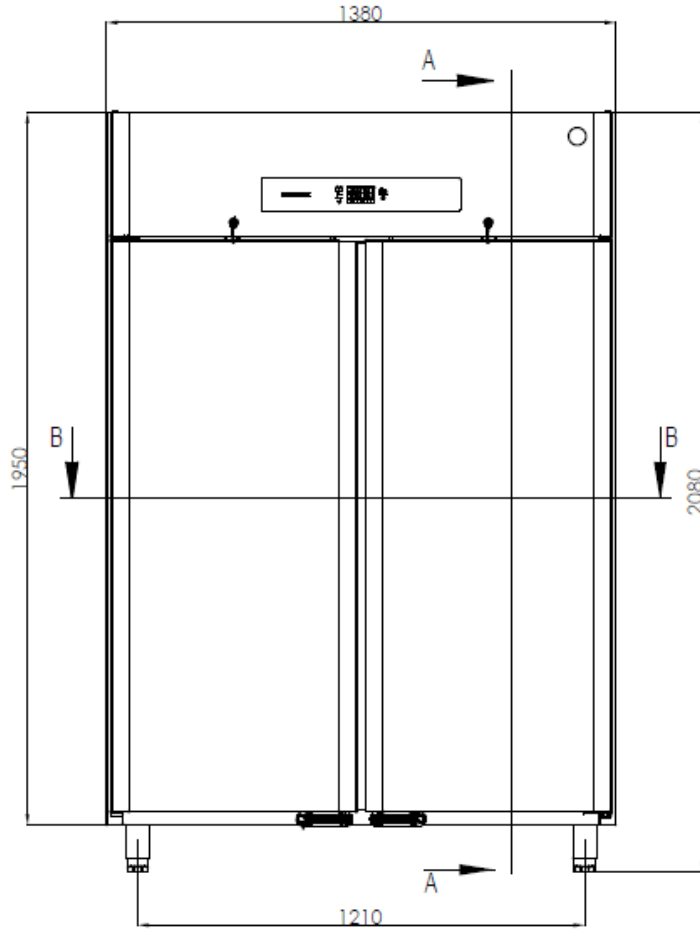

A-A

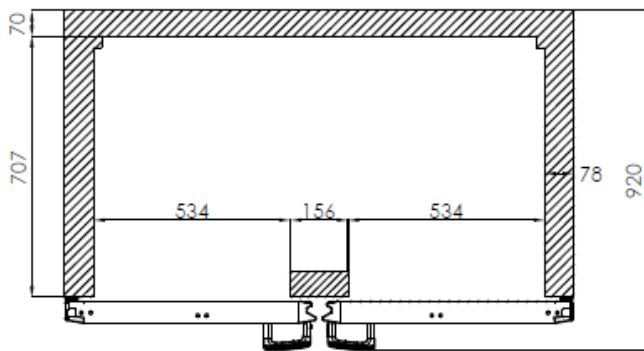

B-B

HOSHIZAKI

Premier Remote Cabinets



BAKER U 950

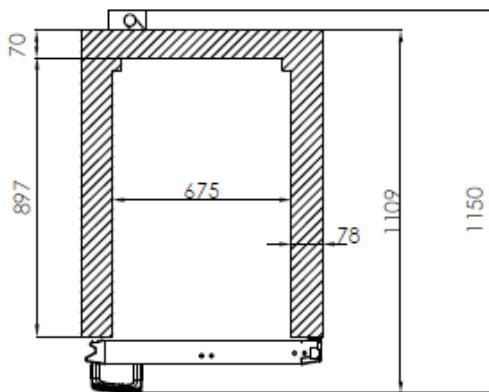
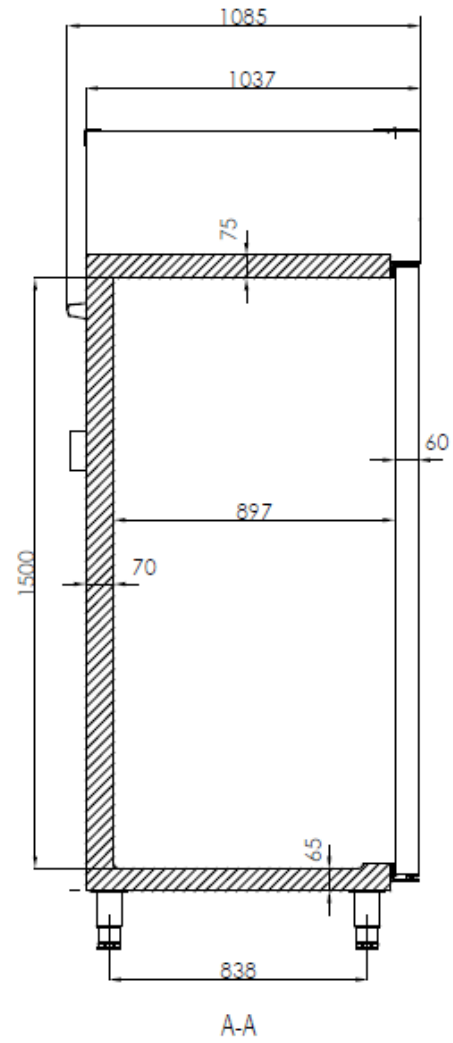
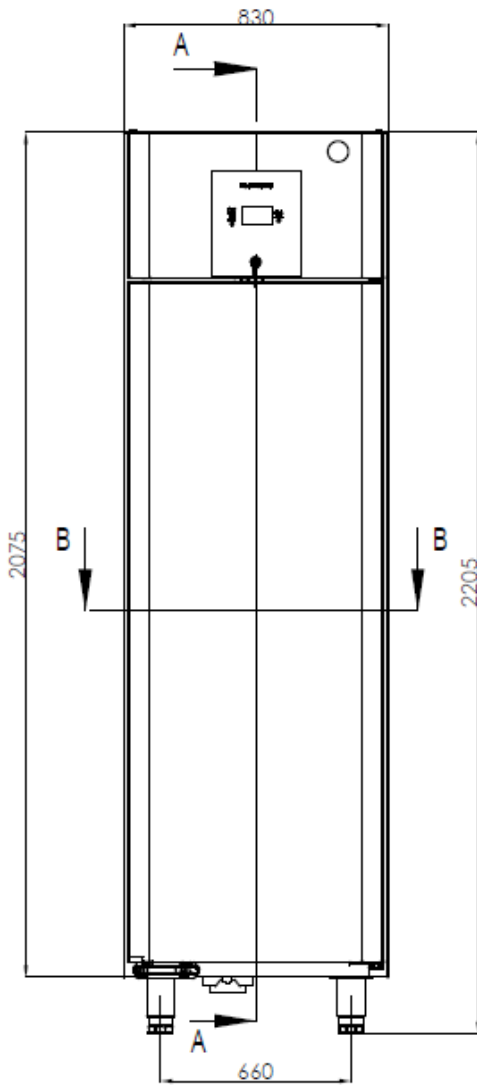

HOSHIZAKI

Premier Remote Cabinets



BAKER GA 950 (RU1)

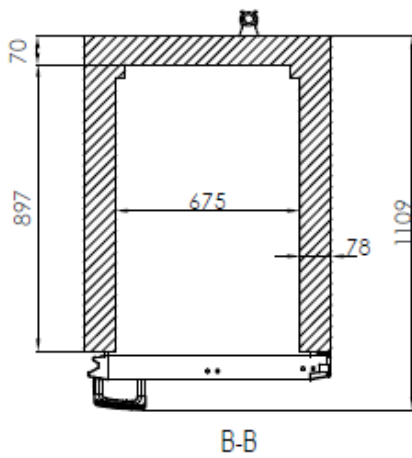
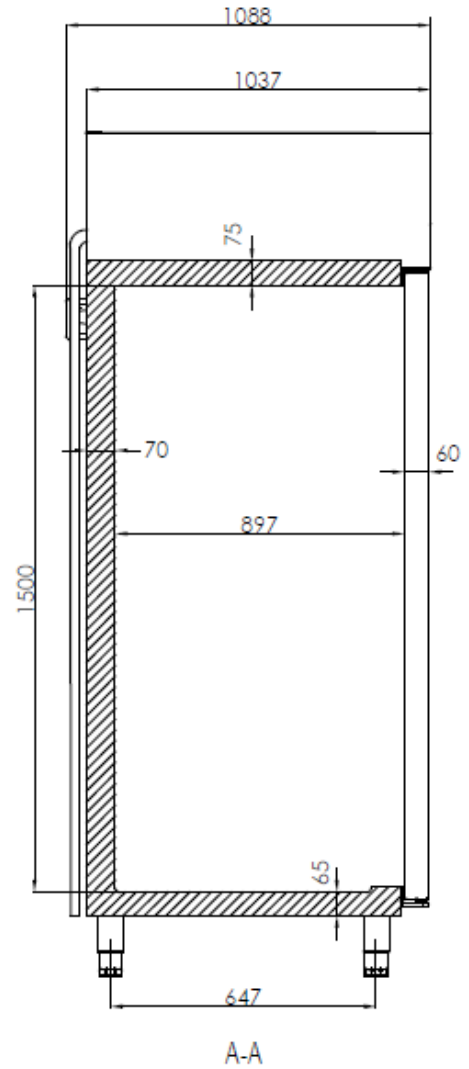
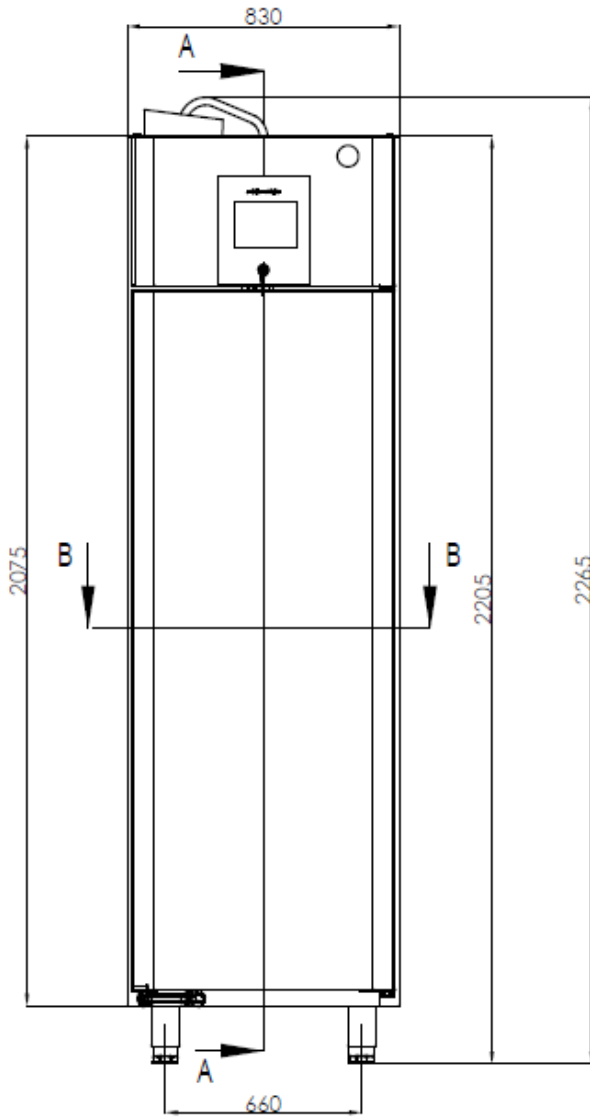

HOSHIZAKI

Premier Remote Cabinets



BAKER SF 950 (RU1)

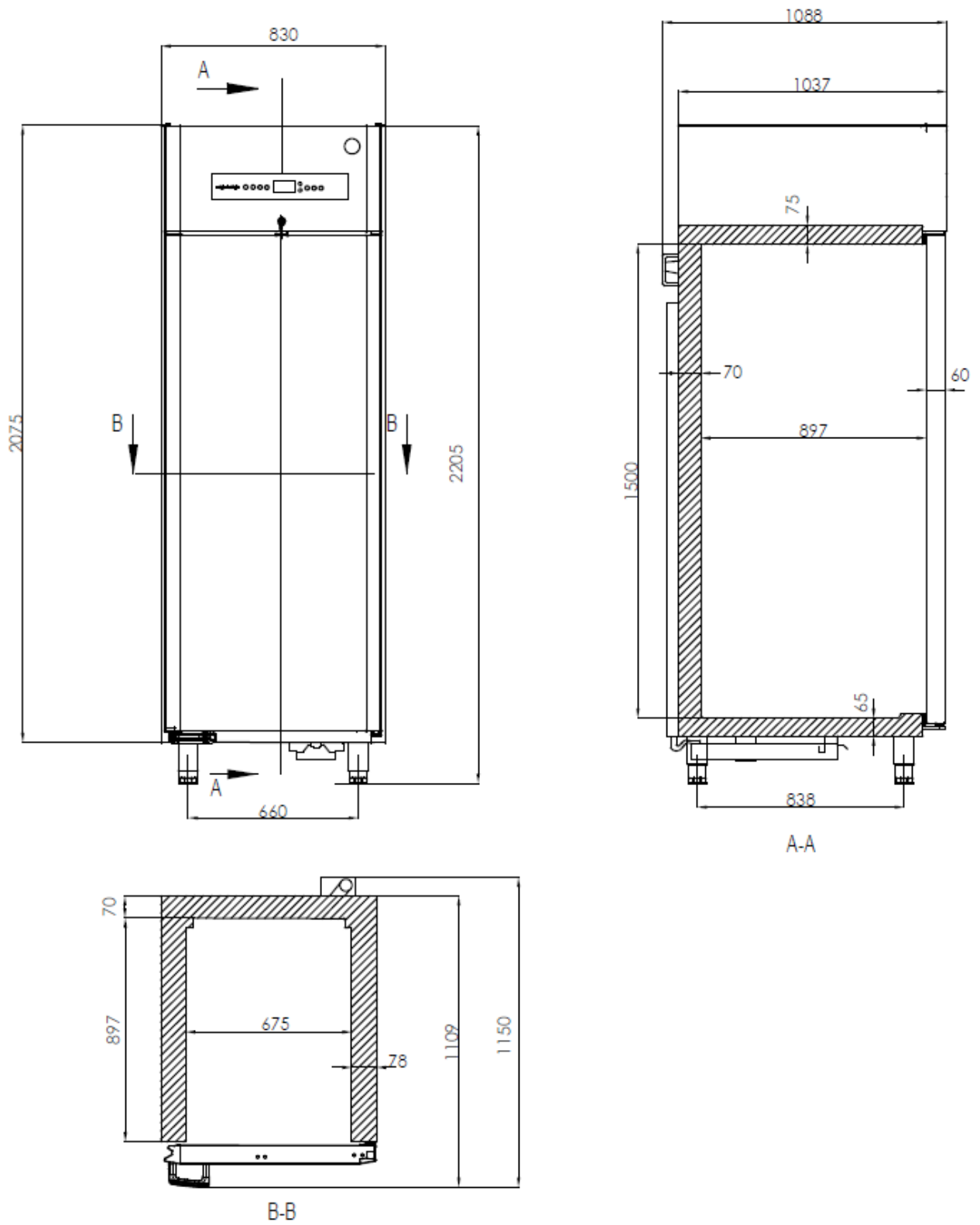

Afvoeren

Het onderstaande heeft alleen betrekking op het Verenigd Koninkrijk.

Een oude kast kan alleen worden afgevoerd als we tegelijk een nieuwe leveren. Kasten moeten volledig ontdooid en geleegd worden voordat ze worden opgehaald.

Hoshizaki erkent dat onze producten voor de horeca als WEEE worden beschouwd wanneer ze verouderd zijn. Om ervoor te zorgen dat de verantwoordelijkheden van Hoshizaki correct en milieuvriendelijk worden afgehandeld, zijn we aangesloten bij de grootste Business to Business-nalevingsregeling in het VK - B2B Compliance <http://www.b2bcompliance.org.uk>

B2B Compliance houdt zich namens ons bezig met alle aspecten van onze verantwoordelijkheden bij het inzamelen en afvoeren van apparatuur die onder de WEEE-regelgeving van het VK valt. U kunt contact opnemen met B2B Compliance via het telefoonnummer 01691 676124.





Elektrisch Bedradingschema

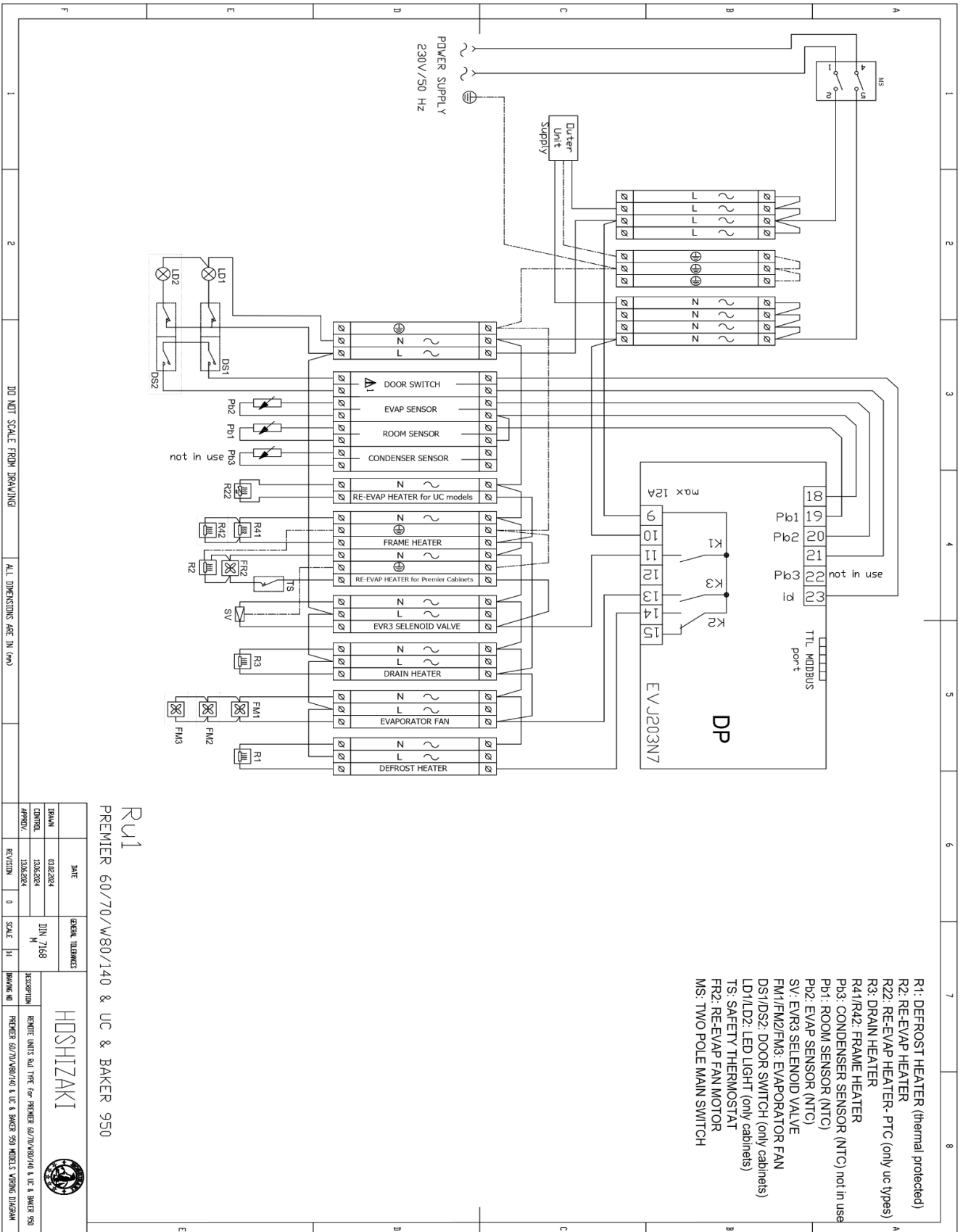

RU1
PREMIER 60/70/W/80/140 & UC & BAKER 950

DATE	GENERAL TOLERANCES	HOSHIZAKI 			
DRAWN	DIN 7168				
CONTROL	M				
APPROV.	13828284	DESCRIPTION			
REVISION	0	SCALE	1:1	DRAWING NO.	PREMIER 60/70/W/80/140 & UC & BAKER 950 MODEL'S VARIANTE DUEMAN

HOSHIZAKI

Premier Remote Cabinets

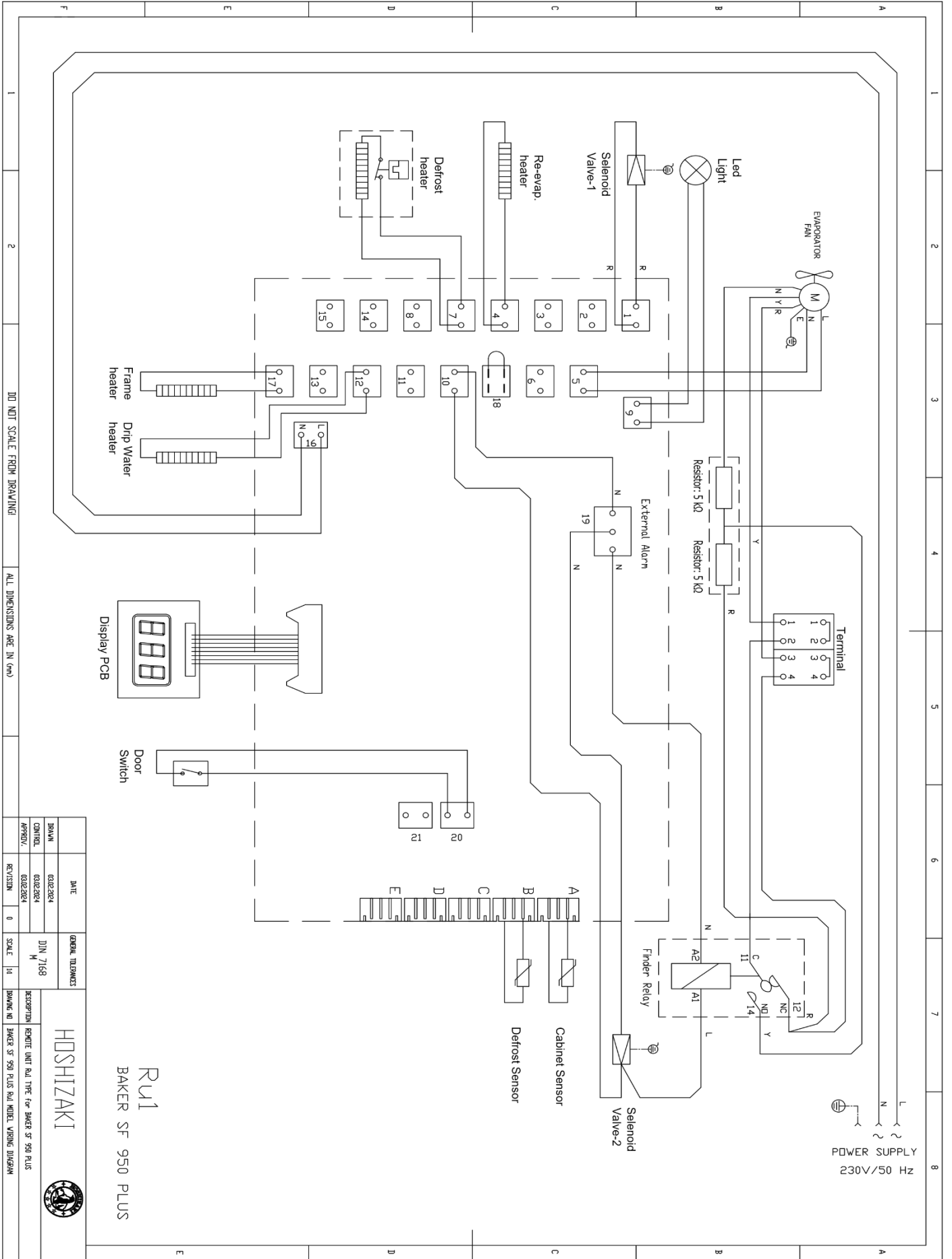

R11
BAKER SF 950 PLUS

DO NOT SCALE FROM DRAWING

ALL DIMENSIONS ARE IN (mm)

GENERAL DIMENSIONS	
DATE	03/23/2014
DRAWN	03/23/2014
CONTROL	03/23/2014
APPROV.	03/23/2014
REVISION	0
SCALE	1:1

HOSHIZAKI



RECEPTION REPORT UNIT RAU TYPE FOR BAKER SF 950 PLUS
DRAWING NO BAKER SF 950 PLUS RAU MODEL VARIOUS DIMENSION

HOSHIZAKI

Premier Remote Cabinets

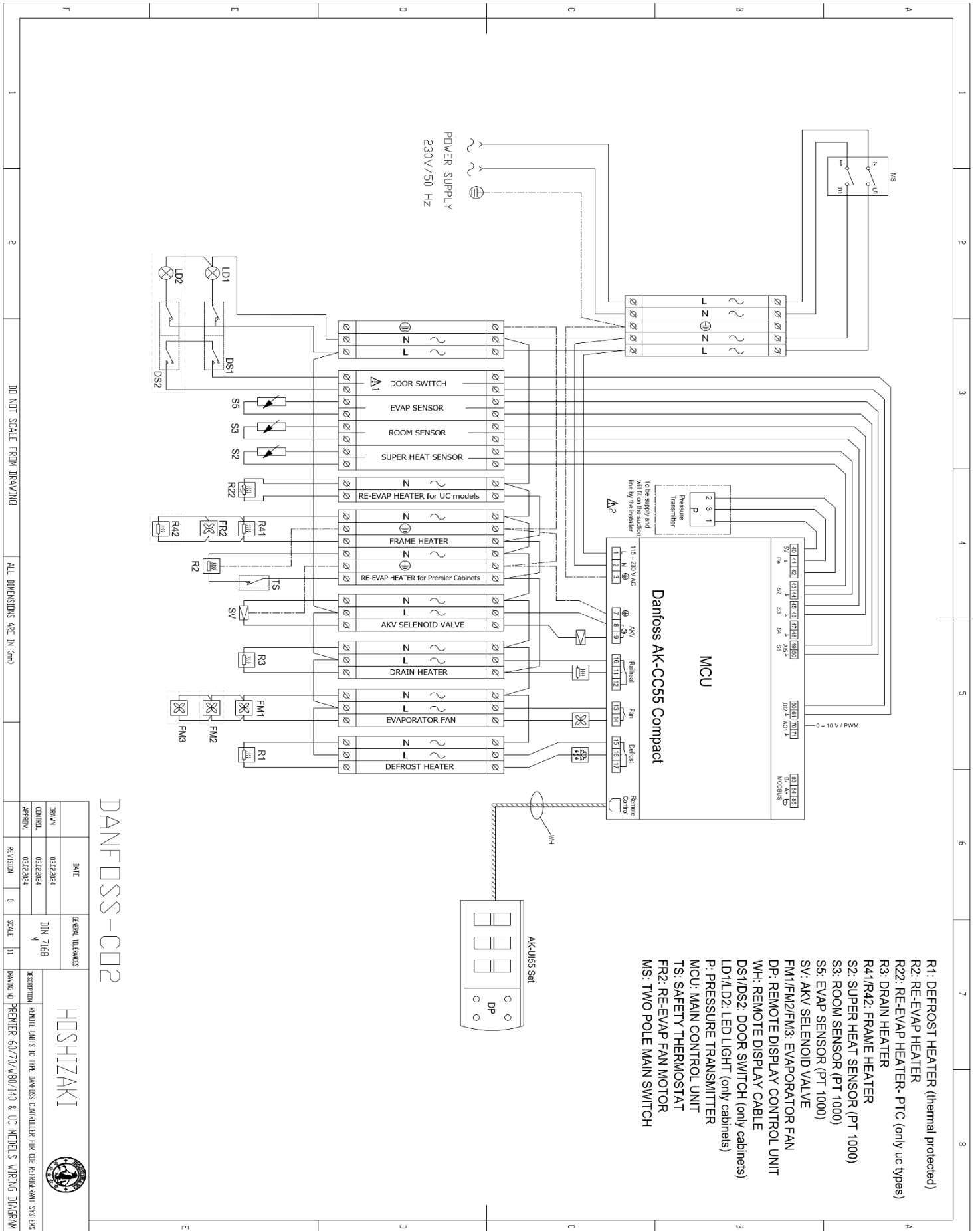

- R1: DEFROST HEATER (thermal protected)
- R2: RE-EVAP HEATER
- R22: RE-EVAP HEATER- PTC (only uc types)
- R3: DRAIN HEATER
- R41/R42: FRAME HEATER
- S2: SUPER HEAT SENSOR (PT 1000)
- S3: ROOM SENSOR (PT 1000)
- S5: EVAP SENSOR (PT 1000)
- SV: AKV SELENOID VALVE
- FM1/FM2/FM3: EVAPORATOR FAN
- DP: REMOTE DISPLAY CONTROL UNIT
- DS1/DS2: DOOR SWITCH (only cabinets)
- W/H: REMOTE DISPLAY CABLE
- P: PRESSURE TRANSMITTER
- MCU: MAIN CONTROL UNIT
- TS: SAFETY THERMOSTAT
- FR2: RE-EVAP FAN MOTOR
- MS: TWO POLE MAIN SWITCH

DANFOSS-CC2

DATE	03.02.2024	GENERAL TOLERANCES	DIN 7168	DESCRIPTION	REMOTE UNITS TO THE DANFOSS CONTROLLER FOR CO2 REFRIGERANT SYSTEMS
DRAWN	03.02.2024			REVISED	
CONTROL	03.02.2024			SCALE	1:1
APPROVED	03.02.2024			DRAWING NO.	PREMIER 60/70/80/140 & UC MODELS WIRING DIAGRAM



HOSHIZAKI

Premier Remote Cabinets

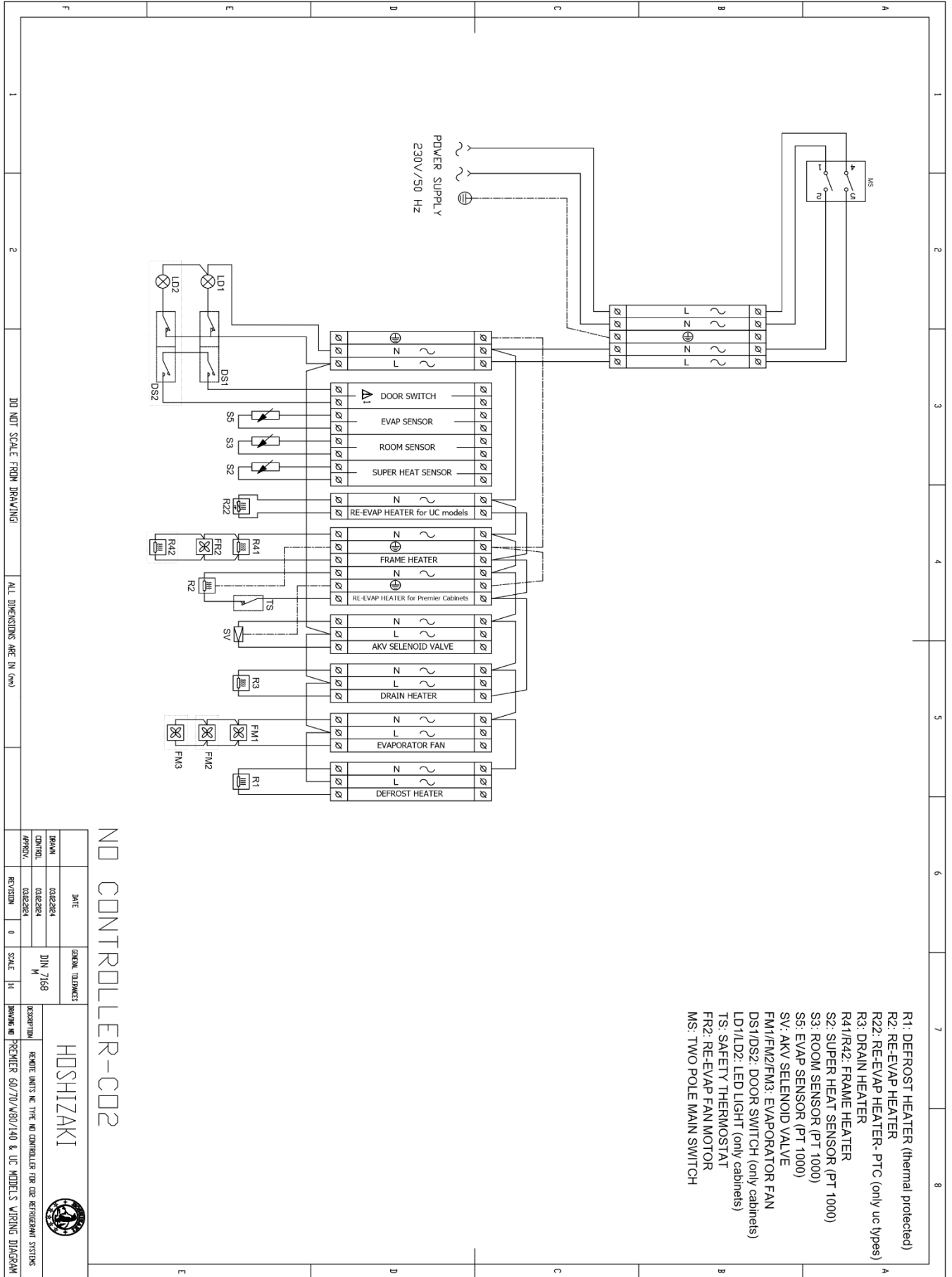

NO CONTROLLER-C02

DATE		GENERAL TOLERANCES		DESCRIPTION	
DATE	03.02.2014	GENERAL TOLERANCES	DIN 7168	DESCRIPTION	REMOTE UNITS NC TYPE NO CONTROLLER FOR C02 REFRIGERANT SYSTEMS
DRAWN	03.02.2014	SCALE	1:1	REVISION	0
CONTROL	03.02.2014	SCALE	1:1	REVISION	0
APPROV.	03.02.2014	SCALE	1:1	REVISION	0



HOSHIZAKI

PREMIER 60/70/80/140 & UC MODELS WIRING DIAGRAM

HOSHIZAKI

Premier Remote Cabinets



Koelschema's

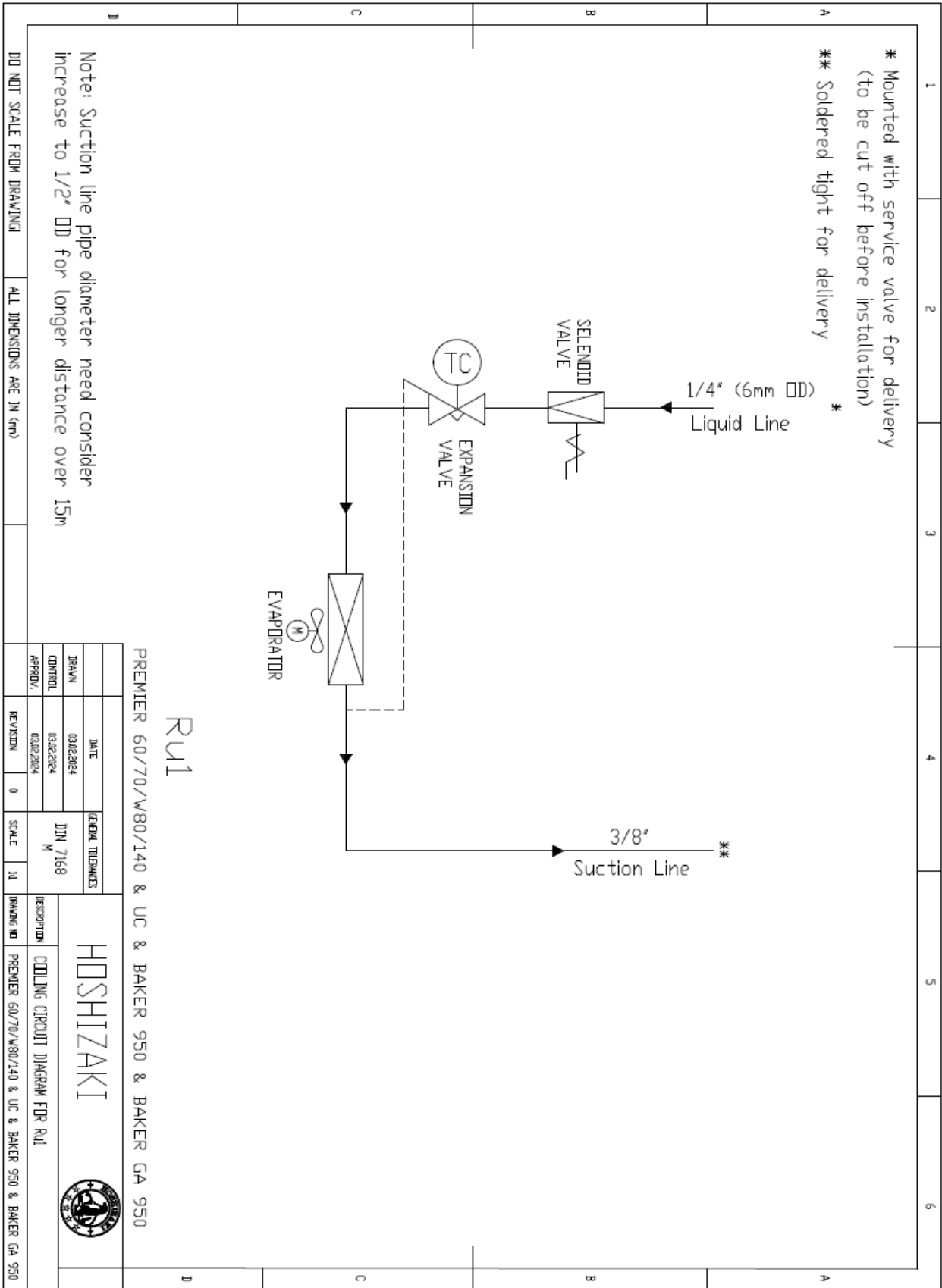

HOSHIZAKI

Premier Remote Cabinets

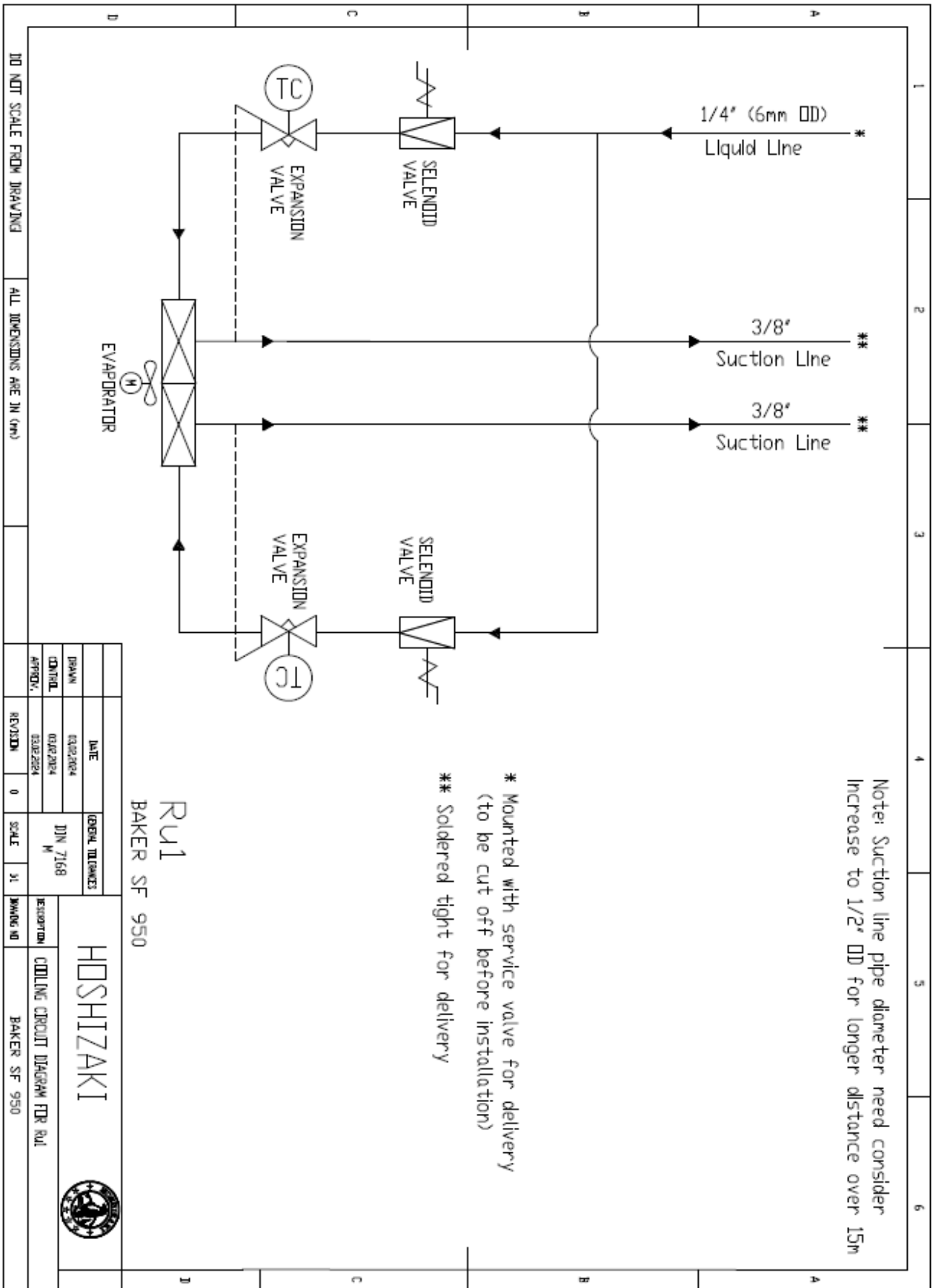

HOSHIZAKI

Premier Remote Cabinets

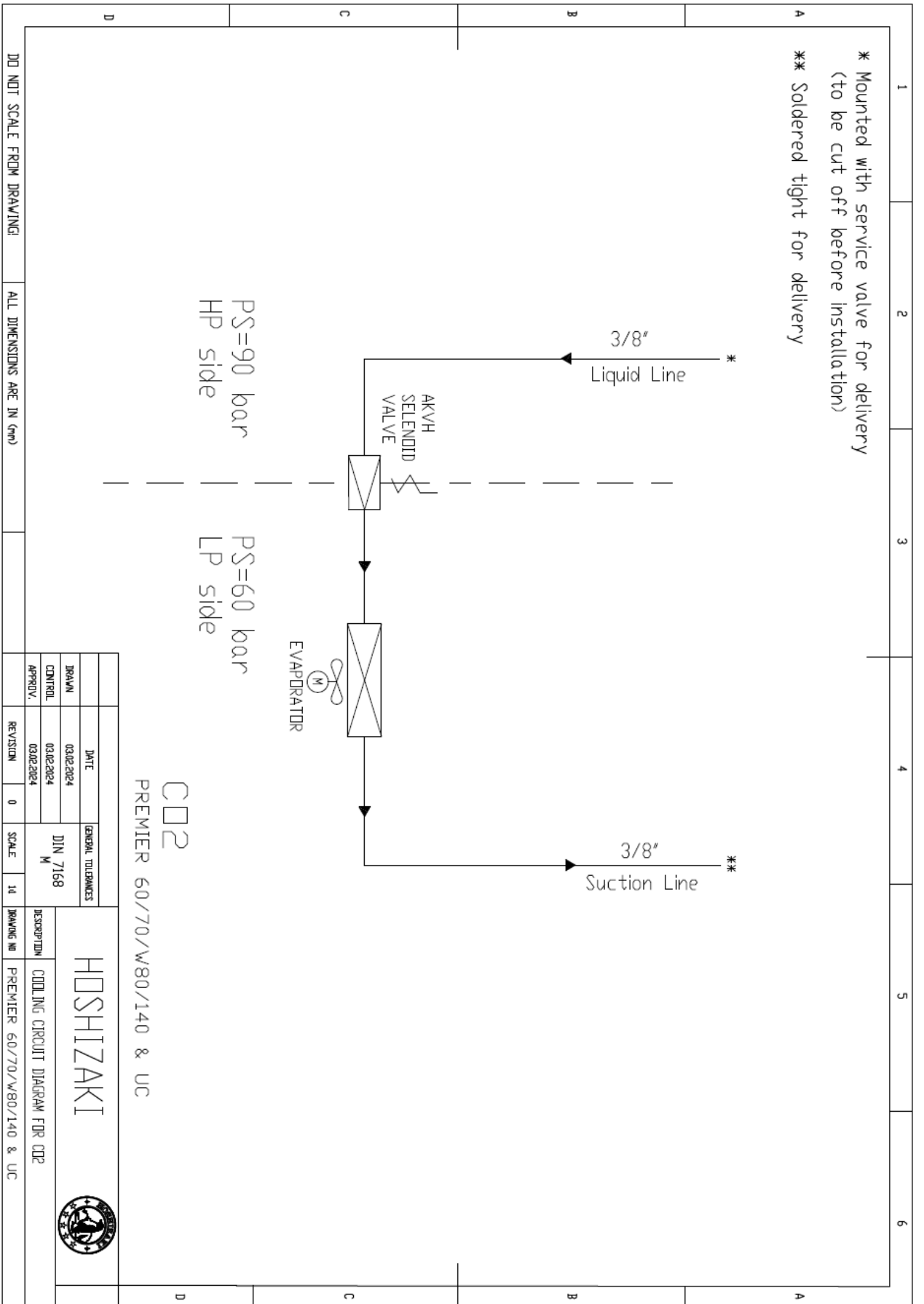

HOSHIZAKI

Premier Remote Cabinets



Alle rechten voorbehouden

Hoshizaki behoudt zich het recht voor om functies en de inhoud van deze handleiding te wijzigen.

Contactgegevens

Hoofdkantoor

Hoshizaki Europe B.V.

TEL: +31 20 691

8499

Sales@hoshizaki.nl

<http://hoshizaki->

[europe.com/](http://hoshizaki-europe.com/)

Vestigingen

Hoshizaki UK - VK, Ierland

TEL: +44 845 456 0585

uksales@hoshizaki.co.uk

Hoshizaki Deutschland - Duitsland, Zwitserland, Oostenrijk

TEL: +49 2154 92810, +49 5066 604612

info@hoshizaki.de

Hoshizaki BENELUX - Nederland, België, Luxemburg

TEL: +31 20 565 0420, +31 54 645 4252

sales@hoshizaki.nl

Hoshizaki France - Frankrijk

TEL: +33 1 48 63 93 80

info@hoshizaki.fr

Hoshizaki Iberia - Spanje, Portugal

TEL: +34 93 478 09 52

info@hoshizaki.es

Hoshizaki Middle East - Midden-Oosten

TEL: +971 48 876 612

sales@hoshizaki.ae

Hoshizaki Danmark – Denemarken, Noorwegen, Zweden

TEL: +45 8988 5350

salg@hoshizaki.dk

Hoshizaki Europe B.V. – Alle overige landen in Europa en Afrika

TEL: +31 20 565 0420

sales@hoshizaki.nl

HOSHIZAKI

Premier Remote Cabinets



RU1 OG CO2 FJERNSTYRET BETJENINGS-, VEDLIGEHOLDELSSES- OG INSTALLATIONSVEJLEDNING



Kontaktoplysninger:

HOSHIZAKI EUROPE B.V.

Adresse: Burgemeester Stramanweg 101 1101 AA Amsterdam, Holland

Tlf.: +31 (0)20 691 84 99 - <http://hoshizaki-europe.com/>





Indholdsfortegnelse

Anvendelse.....	213
Sikkerhedsoplysninger	214
Placering	215
Elektrisk tilslutning	217
Generel brug.....	218
Betjening af produktet (Evco-styreenhed - RU1-model)	219
Betjening af produktet (Danfoss-styreenhed AK - CC55)	220
Betjening af produktet (Carel MPXpro-styreenhed)	223
Betjening af produktet (ingen styreenhed - NC-model).....	229
Fejlfinding	229
Afrimningsvand.....	230
Dørens lukkemekanisme	230
Strømsvigt	230
Rengøring.....	230
Dørpakninger.....	231
Langtidsopbevaring	231
Service	231
Tekniske data	232
Mål.....	234
Bortskaffelse.....	241
Ledningsdiagrammer.....	242
Kølediagrammer	248

HOSHIZAKI

Premier Remote Cabinets



Tak for dit valg af et kvalitetsprodukt fra Hoshizaki.

Denne vejledning giver dig råd om, hvordan du installerer, bruger og vedligeholder dit nye produkt.

Før vores produkter forlader fabrikken, gennemgår de en fuld funktions- og kvalitetstest. Skulle du alligevel opleve problemer med produktet, skal du kontakte din lokale forhandler.

Hoshizakis datterselskaber og forhandlere over hele verden står klar til at hjælpe dig.

Produkter produceret af Hoshizaki er dækket af forskellige garantivilkår i det land, hvor produktet sælges.

Denne garanti er betinget af korrekt brug i henhold til specifikationerne, hvor f.eks. almindelig vedligeholdelse og eventuelle reparationer udføres af teknikere, der er autoriseret af forhandleren, og som har et generelt kendskab til produktet.

Ændringer i installationen og anden brug af produktet end angivet i denne vejledning kan påvirke produktets funktion og holdbarhed.

Vejledningen er udarbejdet i henhold til vores nuværende tekniske viden. Vi arbejder løbende på at opdatere disse oplysninger, og vi forbeholder os ret til at foretage tekniske ændringer.

Anvendelse

Produktet er beregnet til opbevaring af fødevarer i ikke-husholdningsmiljøer.

Produktet er designet til opbevaring af fødevarer ved en konstant temperatur og kan ikke bruges til nedkøling eller nedfrysning af varme/friske fødevarer.

Produktet må kun bruges til det formål, det er udtrykkeligt udviklet til. Enhver anden brug kan medføre, at de fødevarer, der opbevares i produktet, ikke holdes ved den korrekte temperatur eller endda beskadiger produktet.

Produktet er ikke egnet til opbevaring af blodplasma, laboratorieprøver, lægemidler eller lignende stoffer.

Producenten kan ikke gøres ansvarlig for eventuelle skader forårsaget af forkert, ukorrekt eller urimelig brug af produktet.

Sikkerhedsoplysninger

Vigtigt

Beskrivelse af symboler, der anvendes i denne vejledning.



Advarsel Manglende overholdelse af disse anvisninger kan resultere i ulykker med personskade til følge.



Vigtigt Hvis disse anvisninger ikke overholdes, kan produktet blive beskadiget eller ødelagt.

Vær opmærksom på, at Hoshizaki har truffet forholdsregler for at sikre, at produktets sikkerhed er i orden.

Læs følgende oplysninger om sikkerhed omhyggeligt.



Det er vigtigt, at alle, der skal bruge eller installere produktet, har adgang til denne vejledning.



Dette udstyr er ikke beregnet til at blive brugt af personer med nedsatte fysiske, sensoriske eller psykiske evner eller mangelfuld erfaring eller viden, medmindre de er under opsyn eller har modtaget anvisning i brug af udstyret af en person, der er ansvarlig for deres sikkerhed.



Børn bør holdes under opsyn for at sikre, at de ikke leger med udstyret.



Udstyret kan indeholde dele med skarpe kanter i kompressorummet og i det indvendige rum.



Udstyret må ikke transporteres på en sækkevogn, da der er risiko for at miste balancen, hvilket kan medføre personfare.



Der må ikke trækkes i netledningen for at frakoble udstyret, eller når udstyret flyttes.

Placering

Kontroller emballagematerialet for beskadigelse ved modtagelse af produktet.

Hvis emballagematerialet er beskadiget, bør det undersøges, om produktet også er beskadiget. Hvis skaden er betydelig, skal du kontakte din forhandler.



Denne opgave kræver mindst 2 personer. Den tungeste del af produktet er øverst. Vær opmærksom på dette, når du fjerner transportpallen.



På grund af produktets tunge vægt kan gulvet blive beskadiget eller ridset, når produktet flyttes.



Korrekt opstilling giver den mest effektive drift.



Produktet skal placeres i et tørt og tilstrækkeligt ventileret rum.



For at sikre effektiv drift må det ikke placeres i direkte sollys eller mod varmeafgivende overflader. Produktet er designet til at fungere i en omgivelsestemperatur på mellem +16°C og +40°C.



Undgå at placere produktet i et klor-/syreholdigt miljø (svømmehal osv.) på grund af risiko for korrosion.



Produktet og dele af interiøret er udstyret med en beskyttelsesfilm, som skal fjernes før brug.



Rengør produktet med en mild sæbeopløsning før brug.

Opstillingsstedet skal være plant og vandret.

For versioner med ben skal du bruge de justerbare ben til at sikre, at produktet står plant og lodret.

For versioner med hjul skal låseanordningerne på de to forreste hjul være aktiveret, når produktet er på plads.

HOSHIZAKI

Premier Remote Cabinets



Der skal altid være 500 mm frihøjde over produktet af hensyn til service. Produktet skal placeres så tæt som muligt op ad væggen.

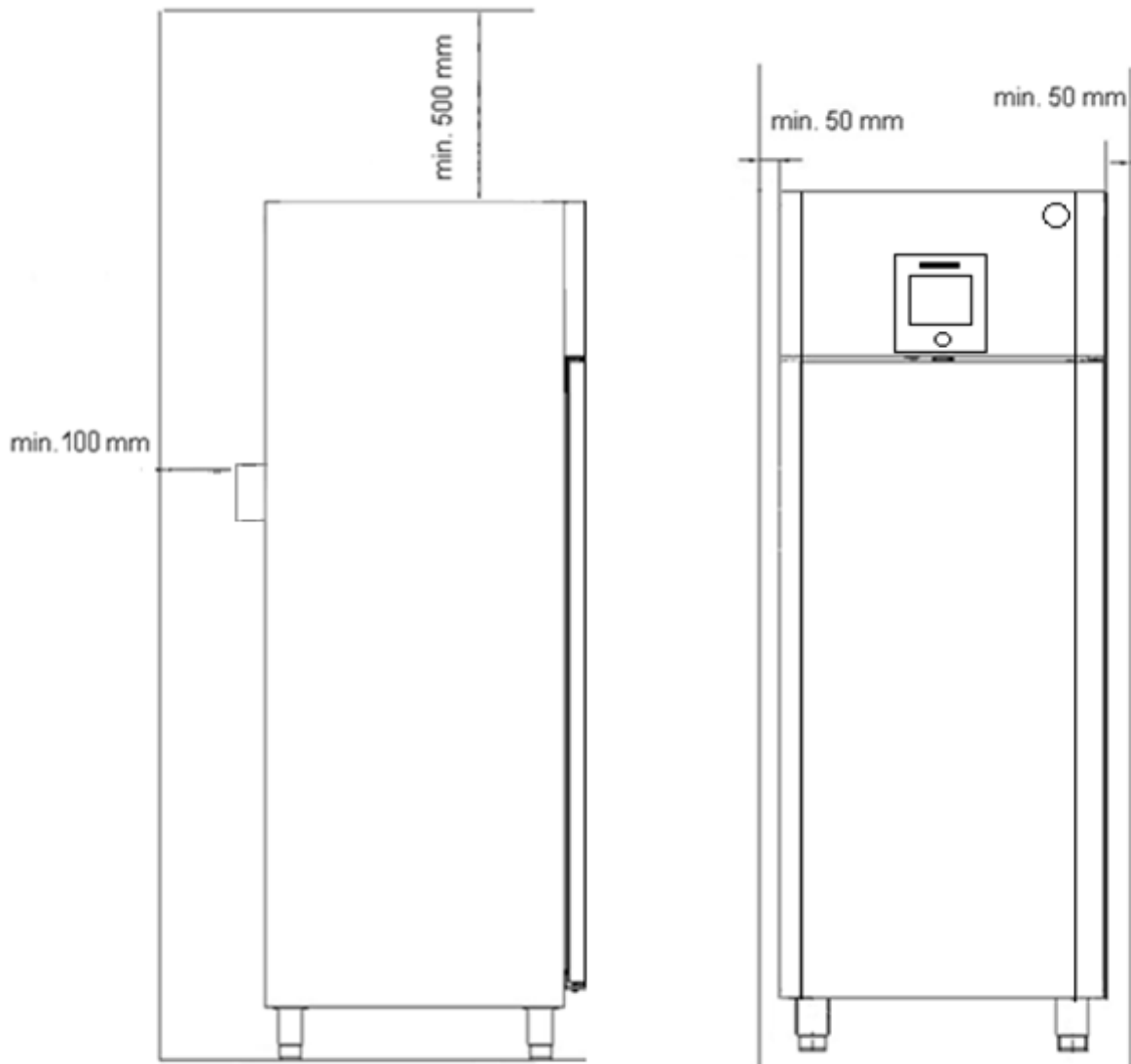

Elektrisk tilslutning

Læs nedenstående tekst grundigt før elektrisk tilslutning.



Produktet er beregnet til tilslutning til vekselstrøm. Tilslutningsspændingen (V) og frekvensen (Hz) er vist på typeskiltet i skabet



Brug aldrig en forlængerledning til dette udstyr!

Hvis en stikkontakt er placeret længere væk end længden på den medfølgende netledning, skal du kontakte en elektriker for at få etableret en stikkontakt inden for netledningens rækkevidde.



Hvis produktet er defekt, **skal det undersøges af en kvalificeret servicetekniker**, som er bekendt med den installerede styreenhed og har erfaring med at vedligeholde CO2-skabet.



Generelt bør det undersøges af det firma, der har tilsluttet produktet.



Afbryd altid strømmen, hvis der opstår afbrydelser i strømforsyningen, når elektriske dele af- eller påmonteres, og før rengøring og vedligeholdelse af produktet.



Produktet må kun anvendes, når alle beskyttelsesdele er monteret. Dette er for at undgå berøring af strømførende eller roterende maskindele

Produktet må ikke bruges udendørs.



Alle krav til jordforbindelse, der er foreskrevet af de lokale elmyndigheder, skal overholdes. Stikket og stikkontakten skal derefter sikre korrekt jordforbindelse. Kontakt en elektriker, hvis det er nødvendigt.



Kontroller, at produktet er slukket ved stikkontakten, eller at stikket til elkedlen er taget ud, før der udføres service på elektriske dele. Det er ikke tilstrækkeligt at slukke for produktet ved styreenheden.

Generel brug



Kølesystemets dele må ikke beskadiges.



Hvis produktet er udstyret med en genfordampningsbakke under skabet, er det vigtigt ikke at servicere/rende bakken eller varmelegemet, før skabet har været slukket længe nok til at sikre, at genfordampningsvarmelegemet er kølet af, så risikoen for forbrændinger forhindres.



Undlad at bruge elektriske apparater inde i produktet.



For at sikre en korrekt og effektiv luftgennemstrømning i skabet skal de skraverede områder holdes fri for genstande.



Alle genstande, der skal opbevares, og som ikke er pakket ind, skal tildækkes for at undgå unødvendig korrosion af skabets indre dele.



Hvis nogen af styreenhedens parametre ændres i forhold til standardindstillingerne, kan det medføre, at produktet ikke fungerer normalt, og at skadelige temperaturer kan beskadige de genstande, der opbevares inde i produktet.



Maksimal hyldebelastning: 40 kg



Undlad at opbevare eksplosive stoffer såsom spraydåser med brændbar drivgas i udstyret.



Produkter må ikke placeres under den nederste hylde eller over den øverste belastningslinjemarkering.

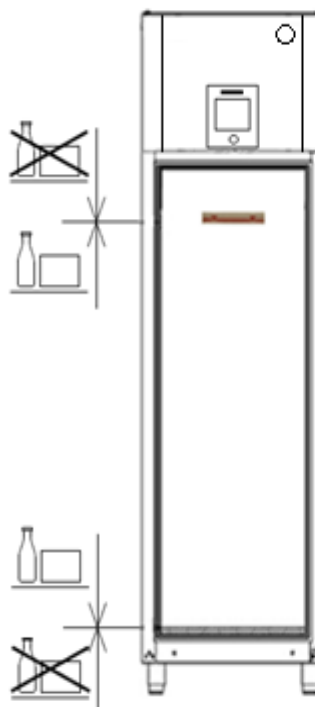

Do not store goods above the top loading mark

Do not store goods below the bottom grate

Betjening af produktet (Evco-styreenhed - RU1-model)

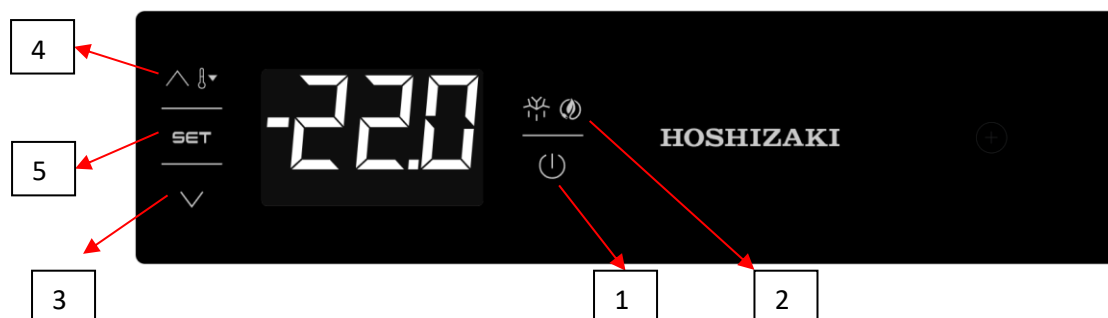

➤ FRONTPANELFUNKTIONER

For at låse frontpaneltasterne skal AUX (3) og On/Stand By (1) holdes nede i 2 sekunder: Teksten "Loc" vises på skærmen, når tasterne er låst, hvis de ikke er låst, vises teksten "UnL" på skærmen.

1) Når **ON/STAND BY** holdes nede i 4 sekunder, åbner eller lukker enheden. (On/Off)

2) **MANUEL AFRIMNING**. Hvis knappen holdes nede i 4 sekunder, starter manuel afrimning. Hvis ekstra køling er aktiveret, og fordampertemperaturen ikke er passende, starter manuel afrimning ikke.

3) **NED**-tasten: Rul ned i menuen, eller reducer værdien. Hvis den holdes nede i 4 sekunder, aktiveres superkøling. Når ekstra kølefunktion er aktiveret, kan den indstillede temperatur reduceres. Klokkeslæt og temperatur fastsættes ved hjælp af parametrene. Når ekstra kølefunktion er aktiveret, afrimer enheden aldrig.

4) **OP**-tasten: Rul op i menuen, eller øg værdien. Hvis den holdes nede i 4 sekunder, aktiveres funktionen til procentdel af lav og høj relativ luftfugtighed. (For nogle modeller) står der "rhL" på skærmen (en funktion med lav procentdel af relativ luftfugtighed er aktiveret), eller der står "rhH" på skærmen (en funktion med høj procentdel af relativ luftfugtighed er aktiveret). Disse funktioner vises på skærmen i 10 sekunder. Hvis styring af fugtighed ikke er tilgængelig, vises "----" på skærmen i 1 sekund.

5) **SET**-tasten: Indtastnings- og ændringstast for justerbare værdier.

➤ Drift

Driftstilstande vises nedenfor:

Status "**On**": Enheden strømforsynes og er i drift.

"**Standby**"-status: Enheden er slukket, men strømforsynes stadig.

Status "**Off**": For at slukke enheden skal stikket tages ud af stikkontakten, eller der skal slukkes på hovedafbryderen.

Betjening af produktet (Danfoss-styreenhed AK - CC55)

Start:

Sæt udstyrets stik i stikkontakten.

Kontroller, at der er tændt på den 2-polede hovedafbryder.

Forklaring af displayet (AK-UI55):

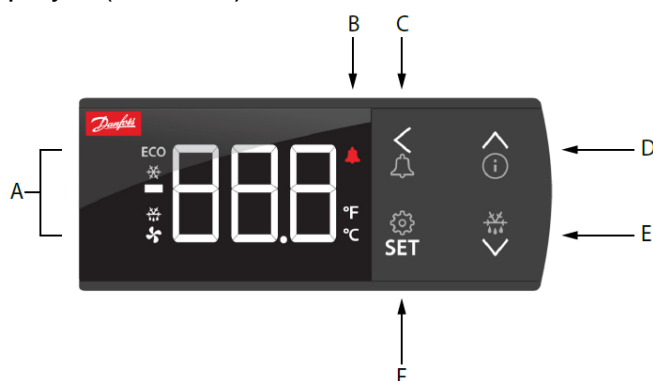

Displaydele	Beskrivelse
A	<p>Lyser i tilfælde af:</p> <ul style="list-style-type: none"> - Energioptimering (ECO) - Køling - Afrimning - Ventilator drift
B	Lyser i tilfælde af alarm
C	Langt tryk (3 sekunder) på alarmknappen alarm (relæet er nulstillet) alarmkode vises
D	<p>Langt tryk (3 sekunder) giver adgang til informationsmenuen "Inf" (se fig. "b")</p> <p>Pil op / pil ned / pil til venstre: Navigation i menuen og indstilling af værdier.</p>
E	<p>Langt tryk (3 sekunder) starter en afrimning, "-d-" vises i displayet.</p> <p>En igangværende afrimning kan stoppes med et langt tryk.</p>
F	<p>SET: Langt tryk (3 sekunder) giver adgang til menuen "SET".</p> <p>Hvis betjeningen er låst med en adgangskode, vises "PS". Indtast koden. *</p> <p>Viser indstillingen for en valgt parameter / gemmer en ændret indstilling. Kort tryk giver adgang til indtastning af termostatens udkoblingsgrænse.</p>

* Fabriksindstillingen for P89 er '0'. Dette trin springes over uden nogen inputværdier.

HOSHIZAKI

Premier Remote Cabinets



a- "SET"-knap parameterliste

b – "Info"-knap parameterliste

SET	←	SET button, 3 s: Configuration settings	
Set			
(PS) v	←	PS: Password (if any)	
cFg	SET →		r12 Main switch
v			o61 Application
r--	Menu groups See also the following pages.		o03 MODBUS address
A--		r89 Food type	
c--		r00 Cut-out temperature	
d--		r15 Ther. sensor S4 %	
n--		r61 Ther. sensor S4% night	
F--		A36 Alarm sensor S4%	
t--		o17 Display air S4%	
h--		o30 Refrigerant type	
o--		o20 Min. transmitter range	
p--		o21 Max. transmitter range	
q--		d01 Defrost method	
u--		d03 Defrost interval	
<		d10 Defrost sensor	
(Return)	d04 Max. defrost time		
	d02 Defrost stop temperature		
	<		
	(Return)		

^	←	Info button, 3 s: Information for service use	
Inf			
StA	SET	See control state message	
App	SET	See selected application	
in	SET →		Al1 (PE)
out	SET →		Al2 **
buS	SET	MODBUS quality	Al3 **
SoF	SET	See SW version	Al4 **
<			Al5 **
(Return)			di1 **
			di2 **
			<
			(Return)

do1	*	Read output status
do2	*	
do3	*	
do4	*	
Ao1	**	Read input status
<		

Output status
When you want info on a relay output, the dot will show whether the relay is activated (energized)
for e.g.:
do4 = not activated
do.4 = activated

Fejlmeddelelser (alarmer)



I en fejlsituation vil alarm-LED'en på fronten lyse, og alarmrelæet vil blive aktiveret (afhængigt af prioritet). Hvis du trykker på alarmknappen i 3 sekunder, kan du se alarmrapporten i displayet.

Se vejledningen til den valgte CO₂-styreenhed for at få flere oplysninger (Danfoss AK-CC55 Compact).

Code	Alarm text	Description
E01	Hardware failure	The controller has a hardware failure
E06	Clock lost time	Clock has lost valid time
E20	Pe Evap. pressure A - Sensor error	Sensor signal is out of range. Please check the sensor for correct operation
E24	S2 Gas outlet A - Sensor error	Sensor signal is out of range. Please check the sensor for correct operation
E25	S3 Air ON evap. A - Sensor error	Sensor signal is out of range. Please check the sensor for correct operation
E26	S4 Air OFF evap. A - Sensor error	Sensor signal is out of range. Please check the sensor for correct operation
E27	S5 Evaporator A - Sensor error	Sensor signal is out of range. Please check the sensor for correct operation
A01	High temperature alarm A	The alarm temperature has been above the max alarm limit for a longer time period than the set alarm delay.
A02	Low temperature alarm A	The alarm temperature has been below the min alarm limit for a longer time period than the set alarm delay.
A04	Door open alarm	The door has been open for a too long time
A05	Max defrost hold time exceeded	The controller has been waiting longer time than permitted after a co-ordinated defrost.
A11	Refrigerant not selected	The refrigerant has not been selected hence control can not be initiated
A15	DI alarm 1	Alarm signal from digital input signal
A16	DI alarm 2	Alarm signal from digital input signal
A45	Main switch set OFF	The controller main switch has been set to either Stop or Manual control. Alternatively a digital input set up for "main switch" function, has stopped control
A59	Case in cleaning mode	A case cleaning operation has been started on a case
AA2	CO ₂ leak detected	CO ₂ is leaking from the refrigeration system
AA3	Refrigerant leak detected	Refrigerant is leaking from the refrigeration system
a04	Wrong IO configuration	Inputs and outputs have not been configured correctly

Betjening af produktet (Carel MPXpro-styreenhed)

Start

Sæt udstyrets stik i stikkontakten

Standardindstillingen for skabets styreenhed er, at den leveres tændt. Det betyder, at styreenheden begynder at regulere, når strømforsyningen er tilsluttet, og hovedafbryderen står i tændt position.

Sådan tændes/slukkes skabet

Brug den 2-polede hovedafbryder på venstre side af elkassen, der er placeret i "kompressorrummet", til at tænde/slukke skabet.

Displayet



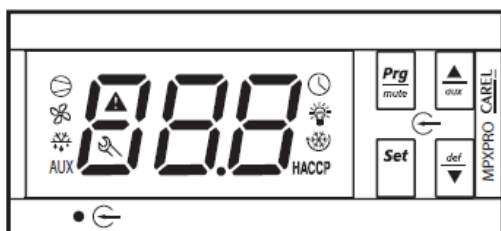

Displayets layout/forklaring:



Det ovenfor viste display har en trecifret udlæsning.

Inden for udlæsningsområdet er der placeret flere LED'er. Disse LED'er angiver følgende.

Generelt = Når en LED blinker, er aktiveringen forsinket eller begrænset.

-  = Køling tændt (når denne LED lyser, er kølingen tændt)
-  = Indvendig ventilator kører (når denne LED lyser, er den indvendige//fordamperventilatoren tændt)
-  = Afrimning tændt (når denne LED lyser, er der en afrimningscyklus i gang)
-  = Hvis LED'en blinker, angiver det, at døren er åben, eller at der er en igangværende alarm eller fejl.

HACCP = Når denne LED lyser, er der en HACCP-alarm i gang. Når denne LED blinker, er der en gemt HACCP-alarm.

Knapper:

De 4 knapper på højre side af displayet bruges til at få adgang til og justere forskellige parametre. Der kan trykkes på disse knapper alene eller i kombination for at betjene styreenheden.

De nedenfor forklarede indstillinger er de eneste, der bør ændres af slutbrugeren. Slutbrugeren må ikke ændre parametre, som ikke er forklaret her. Alle andre indstillinger skal foretages af en kvalificeret tekniker.

BRUGERINDSTILLINGER

Justering af skabstemperatures setpunkt



: omhoog



: omlaag



:Set



: Prg/mute

- Tryk og hold Set nede under normal drift, indtil displayet begynder at blinke, og skabstemperatures setpunkt kan justeres ved hjælp af op og ned .
- Når setpunktet er justeret til den ønskede temperatur, trykkes der kortvarigt på Set for at gemme den nye værdi og vende tilbage til normal drift.

Sådan udfører du en manuel afrimning





- Tryk og hold def nede i mere end 5 sekunder under normal drift for at udføre en manuel afrimning, hvis fordampersens temperatur er kold nok.
- Når afrimningssymbolet  lyser, betyder det, at der er en afrimning i gang.
- Hvis der trykkes på def , og denne holdes nede i mere end 5 sekunder, når en afrimningscyklus er i gang, deaktiveres afrimningen.

Sådan dæmper du akustiske alarmer

- Når styreenheden er i alarmtilstand, hører du et akustisk signal. Alarmen kan dæmpes ved at trykke på Prg/mute .



Indstilling af temperaturalarmgrænser

- Tryk og hold Prg/mute nede i mere end 5 sekunder under normal drift for at åbne parameterlisten. Displayet viser /c1
- Tryk på Prg/mute . Den første kategori af parametre, "Pro", vises
- Tryk på OP , indtil du når kategorien "ALn", hvilket angives ved, at  ikonet lyser på displayet.
- Tryk på Set parameter AA vil blive vist.
- Tryk OP, indtil du når A1
- Tryk på Set for at justere, om indstillingerne for AL (Alarm Lav temperaturgrænse) og AH (Alarm Høj temperaturgrænse) skal være (0 = relativt til skabets temperatursetpunkter) eller (1 = absolut) standardindstilling = 1
- Tryk på Set for at gemme den valgte indstilling og vende tilbage til A1
- Tryk på OP indtil du når AL (**A**larm **L**av temperaturgrænse)
- Tryk på Set for at gøre det muligt at justere AL ved hjælp af op  og ned (justerbar mellem -50 og +50) Standardindstilling = -50°C
- Tryk på Set for at gemme den valgte indstilling og vende tilbage til AL
- Tryk på OP indtil du når AH (**A**larm **H**øj temperaturgrænse)
- Tryk på Set for at gøre det muligt at justere AH ved hjælp af op  og ned (justerbar mellem -50 og +50) Standardindstilling = -50°C
- Tryk på Set for at gemme den valgte indstilling og vende tilbage til AH
- Tryk på OP indtil du når Ad (**A**larm **D**elay (Alarmforsinkelse) for AL og AH)
- Tryk på Set for at gøre det muligt at justere Ad ved hjælp af op  og ned (justerbar mellem 0 og 240 minutter) standardindstilling = 120 minutter.
- Tryk på Set for at gemme den valgte indstilling og vende tilbage til Ad
- Tryk og hold Prg/mute nede i mere end 5 sekunder for at gemme ændringer og vende tilbage til hovedmenuen.

For at skabe temperaturalarmgrænser og alarmforsinkelsestid, der passer til et køleskab eller en fryser, kan nedenstående eksempler på alarmindstillinger foreslås:

	Sætpunkt	A1	AL	AH	Ad
Køleskab	+5 °C	1	+1 °C	+8 °C	120 min.
Fryser	-18 °C	1	-50 °C	-15 °C	120 min.

HOSHIZAKI

Premier Remote Cabinets



Sådan vises alarmloggen

- Tryk på Prg/mute og Set og hold nede i 5 sekunder;
- indtast adgangskoden: 44
- Tryk på Set for at få adgang til en undermenu, hvor OP og NED bruges til at rulle gennem de forskellige alarmer HS0 til HS9;

- Vælg en alarm, og tryk på Set for at få vist kode, time, minutter og varighed;
- Fra enhver af underparametrene vil tryk på Prg/mute få styreenheden til at vende tilbage til den overordnede parameter "HSx";

- Tryk på Prg/mute i 5 sekunder for at vende tilbage til

standarddisplayet. Eksempel:

'HI' -> 'h17' -> 'm23' -> '65'

angiver, at alarmeren 'HI' (alarm for høj temperatur) blev aktiveret kl. 17:23 og varede i 65 minutter.

HACCP-ALARMER

Der håndteres to typer HACCP-hændelser:

- type HA-alarmer, høj temperatur under drift;
- type HF-alarmer, høj temperatur efter strømsvigt (blackout).

Når der registreres en alarm, blinker HACCP-LED'en, displayet viser alarmkoden, alarmeren gemmes, og alarmrelæet og summeren aktiveres.

Sådan vises HA- og HF-alarmerne

- Tryk på Prg/mute og NED samtidigt

- Rul listen over alarmer ved at trykke på OP og NED

- Tryk på Set for at vælge den ønskede alarm
- Brug OP eller NED for at se beskrivelsen af alarmeren: år, måned, dag, timer, minutter og varighed i minutter af den valgte alarm

- Tryk på Prg/mute for at vende tilbage til den foregående liste.

HACCP-alarm-menuen giver desuden mulighed for følgende handlinger:



Sådan slettes en HACCP-alarm

- Tryk på Set og NED i 5 sekunder, når listen over alarmer vises.

Dette får HACCP til at blinke; displayet viser meddelelsen rES, og overvågningen af HACCP-alarmer genstartes

Sådan slettes hele hukommelsen med HACCP-alarmer

- Tryk på Set og OP og NED i 5 sekunder.

Denne procedure viser meddelelsen rES, sletter hele hukommelsen med alarmer og genstarter overvågningen af HACCP-alarmer.

For at kunne bruge HACCP-alarmerne er det nødvendigt, at realtidsuret er justeret af installationsfirmaet, før skabet overdrages til slutbrugeren. Disse justeringer er beskyttet af en adgangskode og kan derfor ikke foretages af slutbrugeren.

Lys i skabet

På alle skabe er skabslyset placeret på ydersiden af skabet over døren. Dette lys betjenes af hovedstyreenheden, hvilket betyder, at den måde, det fungerer på, ikke kan ændres.

Når skabsdøren åbnes, tændes lyset over døren. Når døren lukkes, slukkes skabslyset over døren.

HOSHIZAKI

Premier Remote Cabinets



Fejl og alarmer

Display code	Cause of the alarm	Icon flash on display	Alarm relay	Buzzer	Reset	Compressor	Defrost	Evaporator fans	Continuous cycle	Signalled on tLAN	Network solenoid valve
rE	Control probe fault		ON	ON	automatic	duty setting(c4)	unchanged	unchanged	unchanged	√	-
E1	Probe S1 fault		OFF	OFF	automatic	duty setting(c4)	unchanged	unchanged	unchanged	√	-
E2	Probe S2 fault		OFF	OFF	automatic	unchanged	unchanged	unchanged	unchanged	√	-
E3	Probe S3 fault		OFF	OFF	automatic	unchanged	unchanged	unchanged	unchanged	√	-
E4	Probe S4 fault		OFF	OFF	automatic	unchanged	unchanged	unchanged	unchanged	√	-
E5	Probe S5 fault		OFF	OFF	automatic	unchanged	unchanged	unchanged	unchanged	√	-
E6	Probe S6 fault		OFF	OFF	automatic	unchanged	unchanged	unchanged	unchanged	√	-
E7	Probe S7 fault		OFF	OFF	automatic	unchanged	unchanged	unchanged	unchanged	√	-
E8	Serial probe S8 not updated		OFF	OFF	automatic	duty setting(c4)	unchanged	unchanged	unchanged	√	-
E9	Serial probe S9 not updated		OFF	OFF	automatic	duty setting(c4)	unchanged	unchanged	unchanged	√	-
E10	Serial probe S10 not updated		OFF	OFF	automatic	duty setting(c4)	unchanged	unchanged	unchanged	√	-
E11	Serial probe S11 not updated		OFF	OFF	automatic	duty setting(c4)	unchanged	unchanged	unchanged	√	-
LO	Low temperature alarm		ON	ON	automatic	unchanged	unchanged	unchanged	unchanged	√	-
HI	High temperature alarm		ON	ON	automatic	unchanged	unchanged	unchanged	unchanged	√	-
LO2	Low temperature alarm		ON	ON	automatic	unchanged	unchanged	unchanged	unchanged	√	-
HI2	High temperature alarm		ON	ON	automatic	unchanged	unchanged	unchanged	unchanged	√	-
IA	Immediate alarm from external contact		ON	ON	automatic	duty setting(A6)	unchanged	unchanged	unchanged	√	-
dA	Delayed alarm from external contact		ON	ON	automatic	duty setting(A6) if A7≠0	unchanged	unchanged	unchanged	√	-
dor	Door open for too long alarm		ON	ON	automatic	unchanged	unchanged	unchanged	unchanged	√	-
Etc	Real time clock fault		OFF	OFF	automatic	unchanged	unchanged	unchanged	unchanged	√	-
LSH	Low superheat alarm		OFF	OFF	automatic	OFF	unchanged	unchanged	unchanged	√	√
LSA	Low suction temperature alarm		OFF	OFF	automatic / manual	OFF (paragraph 6.10)	unchanged	unchanged	unchanged	√	√
MOP	Maximum evaporation pressure alarm		OFF	OFF	automatic	OFF	unchanged	unchanged	unchanged	√	√
LOP	Low evaporation temperature alarm		OFF	OFF	automatic	unchanged	unchanged	unchanged	unchanged	√	√
bLo	Valve blocked alarm		OFF	OFF	manual/ disabled with P14=0	unchanged	unchanged	unchanged	unchanged	√	-
Edc	Communication error with stepper driver		ON	ON	automatic	unchanged	unchanged	unchanged	unchanged	√	-
EFS	Stepper motor broken/not connected		ON	ON	automatic	unchanged	unchanged	unchanged	unchanged	√	-
EE	Flash unit parameter error		OFF	OFF	automatic	OFF	not performed	OFF	not performed	√	-
EF	EEPROM operating parameter error		OFF	OFF	automatic	OFF	not performed	OFF	not performed	√	-
HA	Type HA HACCP alarm	HACCP	OFF	OFF	manual	unchanged	unchanged	unchanged	unchanged	√	-
HF	Type HF HACCP alarm	HACCP	OFF	OFF	manual	unchanged	unchanged	unchanged	unchanged	√	-
MA	Communication error with Master (only on Slave)		ON	ON	automatic	unchanged	unchanged	unchanged	unchanged	-	-
u1...u5	Communication error with Slave (only on Master)		ON	ON	automatic	unchanged	unchanged	unchanged	unchanged	-	-
n1...n5	Alarm on unit 1 to 5 in the network		ON	ON	automatic	unchanged	unchanged	unchanged	unchanged	-	-
up1...up5	Upload procedure with errors on unit 1 to 5		OFF	OFF	-	unchanged	unchanged	unchanged	unchanged	-	-
GPE	Error in custom gas parameters		ON	ON	automatic	OFF	not performed	OFF	not performed	√	-



Se vejledningen til den valgte CO2-styreenhed for at få flere oplysninger (Carel MPX PRO).

Betjening af produktet (ingen styreenhed - NC-model)



Se vejledningen, der følger med den installerede styreenhed.

Fejlfinding

Støj:

- Hvis der opstår unormal støj, skal du anmode om serviceassistance.
- Driftslyde fra den indvendige ventilator er normale.
- Hvis metaldele, frontpaneler eller paneler foran rummet støjer, kan disse være åbne. Luk panelerne.

Rim inde i rummet:

- Omgivende luftfugtighed er for høj.
- Døren åbnes for ofte.
- Døren står åben for længe.
- Beskadiget dørpakning. Kontroller den grundigt for skader.

Dårlig køleydelse:

- Omgivelsestemperaturen er for høj.
- Døren åbnes for ofte og/eller er åben for længe.
- Døren er efterladt åben.
- Beskadiget dørpakning.
- For høj temperaturindstilling.
- Produktet er for pakket med fødevarer – luftindtag/-udtag er blokeret.
- Lune eller varme fødevarer inde i produktet.
- Afrimning i gang. Skabstemperaturen kan stige midlertidigt under afrimningscyklussen, men det påvirker ikke fødevarerne indeni. Afrimnings-LED'en lyser.

Nogle af fødevarerne er frosne:

- Produktet er for pakket med fødevarer – luftindtag/-udtag er blokeret.
- Temperaturindstillingen er for lav.
- Fordamperventilatoren kan være defekt.

Kondens omkring døren:

- Omgivende luftfugtighed er for høj.
- Døren lukker ikke tæt.
- Beskadiget dørpakning.
- Parameter relateret til dørkarmvarmer er ikke blevet justeret korrekt.

For højt energiforbrug:

- Omgivelsestemperaturen er for høj.
- Døren åbnes for ofte og/eller er åben for længe.
- Døren er efterladt åben.
- Beskadiget dørpakning.
- Temperaturindstillingen er for lav.
- Produktet er for pakket med fødevarer – luftindtag/-udtag er blokeret.
- Varme eller lune fødevarer er bragt ind i produktet.
- Produktet er placeret i direkte sollys eller tæt på varmeafgivende overflader.
- Standardindstillingerne er ændret.

Afrimningsvand

Under afrimning producerer produktet vand, som ledes ind i genfordampningssystemet gennem vakuumplast øverst i skabet (for Premier-skabe)

Vandet genfordampes med et elektrisk varmeelement og en ventilatormotor. I sjældne tilfælde genererer skabets brugsmønster mere vand, end produktet er i stand til at fordampe igen, hvilket betyder, at der kan forekomme overløb af vand. Hvis dette sker, kan det elektriske varmeelement ændres til at køre 100 % eller alternativt kobles fra og i stedet forbinde vandrøret på bagsiden til et afløb. Disse ændringer skal udføres af en kvalificeret servicetekniker.

Dørens lukkemekanisme

Døren er udstyret med et selvlukkende system. Hvis døren åbnes mindre end 90°, lukker den af sig selv. Hvis døren åbnes mere end 90°, forbliver den åben.

Døren kan åbnes ved hjælp af fodpedalen. På den måde er begge hænder fri ved placering af fødevarer i skabet.

Strømsvigt

I tilfælde af strømsvigt husker styreenheden temperaturindstillingen og genstarter produktet, når strømmen retableres.

Rengøring

Utilstrækkelig rengøring medfører, at produktet ikke fungerer optimalt, eller at det i sidste ende bliver defekt.



Afbryd altid strømmen til produktet før rengøring.



Skyl ikke produktet med vand, og brug ikke vandstråle eller dampslange, da det kan forårsage kortslutning i det elektriske system.



Rengøringsmidler, der indeholder klor eller klorforbindelser, samt andre korroderende midler **må ikke anvendes**, da de kan forårsage korrosion på de rustfrie paneler i skabet og fordamperen.



Produktet skal holdes frit for støv og snavs. Dette gøres bedst med en støvsuger og en børste.



Til udvendig vedligeholdelse – brug pudsemiddel til rustfrit stål.



Produktet skal rengøres indvendigt med en mild sæbeopløsning med passende mellemrum og kontrolleres grundigt, før det tages i brug igen.

Dørpakninger

Dette kapitel handler om vigtigheden af en velfungerende dørpakning.

Pakninger er en vigtig del af et køle-/fryseskab. Pakninger med nedsat funktionalitet reducerer skabets tæthed. Reduceret tæthed kan medføre øget luftfugtighed, indvendig tilisning, en tiliset fordampner (hvilket fører til reduceret kølekapacitet) og i værste fald reduceret levetid for skabet.



Derfor er det vigtigt at være opmærksom på pakningens tilstand. Regelmæssig inspektion anbefales.

Pakningen skal rengøres regelmæssigt med en mild sæbeopløsning.

Kontakt leverandøren, hvis det er nødvendigt at udskifte en pakning.

Langtidsopbevaring

Hvis produktet tages ud af drift og skal klargøres til langtidsopbevaring, skal det indvendige rum, døren og dørpakningen rengøres grundigt med en varm, fugtig klud med sæbe. Eventuelle madrester kan skabe mug.

Service

Hvis kølingen svigter, skal du først undersøge, om enheden utilsigtet er blevet afbrudt eller slukket ved stikkontakten, eller om en sikring er sprunget.

Kontakt installatøren af anlægget, hvis det ikke er muligt at finde årsagen til kølefejlen.

Når du kontakter HOSHIZAKI eller installatøren, bedes du oplyse navn og serienummer inde i skabet. Disse oplysninger er angivet på typeskiltet.

HOSHIZAKI

Premier Remote Cabinets





Tekniske data

Placering af mærkatene:

PRODUCT DESCRIPTION LABEL		
1 Product Number		
2 Product Description		
3 Model		
4 Refrigerant (GWP)		
5 CO2 Equivalent		
6 IP Protection		
7 Climate Class		
8 Production Date		
9 Total power / Current / Lamp power		
10 Voltage - Frequency		
11 Heating Element		
12 System Pressure		
13 Blowing Agent		
14 Serial Number		



PRODUCT NUMBER	1
	
PRODUCT DESCRIPTION	2
MODEL	3
REFRIGERANT	4
CO2 EQUIVALENT	5
IP PROTECTION	6
CLIMATE CLASS	7
PRODUCTION DATE	8
TOTAL POWER / CURRENT / LAMP POWER	9
VOLTAGE - FREQUENCY	10
HEATING ELEMENT	11
SYSTEM PRESSURE	12
BLOWING AGENT	13

S/N: 14 

HOSHIZAKI EUROPE B.V. Burgemeester Stramanweg 101 1101 AA
Amsterdam, The Netherlands



Trade mark			HOSHIZAKI			
Model name			PREMIER U 70	PREMIER U 140	PREMIER U 80	PREMIER U 60
Tilsluttet anvendelse			Storage	Storage	Storage	Storage
Køledriftstemperatur			X	X	X	X
Frysedriftstemperatur			X	X	X	X
Skab med flere funktioner						
Lodret skab			X	X	X	X
Kølebord						
Parameter	Symbol	Unit				
Bruttovolumen	VnT	L	700	1400	700	480
Klimaklasse			CC5	CC5	CC5	CC5
Forsyningsspænding / frekvens	V / Hz		230 - 50	230 - 50	230 - 50	230 - 50
Kølemiddel (CO2 skab)			CO2	CO2	CO2	CO2
Kølemiddel (RU-1 skab)			HFC / HFO Refrigerant*	HFC / HFO Refrigerant*	HFC / HFO Refrigerant*	HFC / HFO Refrigerant*
Kontaktoplysninger:	HOSHIZAKI EUROPE B.V. Address: Burgemeester Stramanweg 101 1101 AA Amsterdam, The Netherlands Tel: +31 (0)20 691 84 99 - http://hoshizaki.europe.com/					

* Kølemidler, der er kompatible med åbning (R449A, R448A, R45A osv. Kontroller databladet for brug af åbning)

HOSHIZAKI

Premier Remote Cabinets



Trade mark			HOSHIZAKI		
Model name			BAKER U 950	BAKER GA 950	PREMIER SF 950
Bedoeld gebruik			Storage	Cooling /Freezing / Storage / Proving	Cooling / Shock Freezing
Gekoelde bedrijfstemperatuur			X	X	X
Bevroren bedrijfstemperatuur			X	X	X
Multifunctionele kast				X	X
Verticale kast			X	X	X
Werkbank					
Parameter	Symbol	Unit			
Brutovolume	VnT	L	1000	950	950
Klimaatklasse			CC5	CC5	CC5
Voedingsspanning/frequentie	V / Hz		230 - 50	230 - 50	230 - 50
Koelmiddel (RU-1-kast)			HFC / HFO Refrigerant*	HFC / HFO Refrigerant*	HFC / HFO Refrigerant*
Contactgegevens:			HOSHIZAKI EUROPE B.V. Address: Burgemeester Stramanweg 101 1101 AA Amsterdam, The Netherlands Tel: +31 (0)20 691 84 99 - http://hoshizaki.europe.com/		

* Kølemidler, der er kompatible med åbning (R449A, R448A, R45A osv. Kontroller databladet for brug af åbning)

HOSHIZAKI

Premier Remote Cabinets



Mål

PREMIER U 70

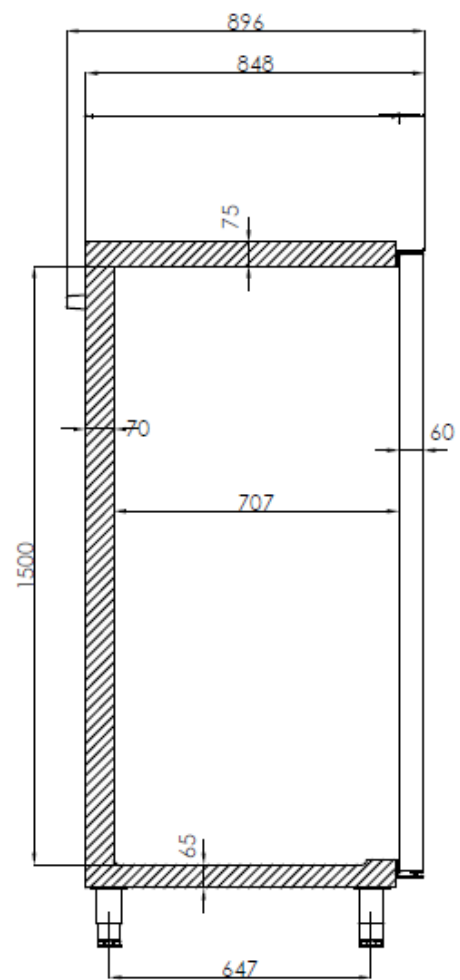
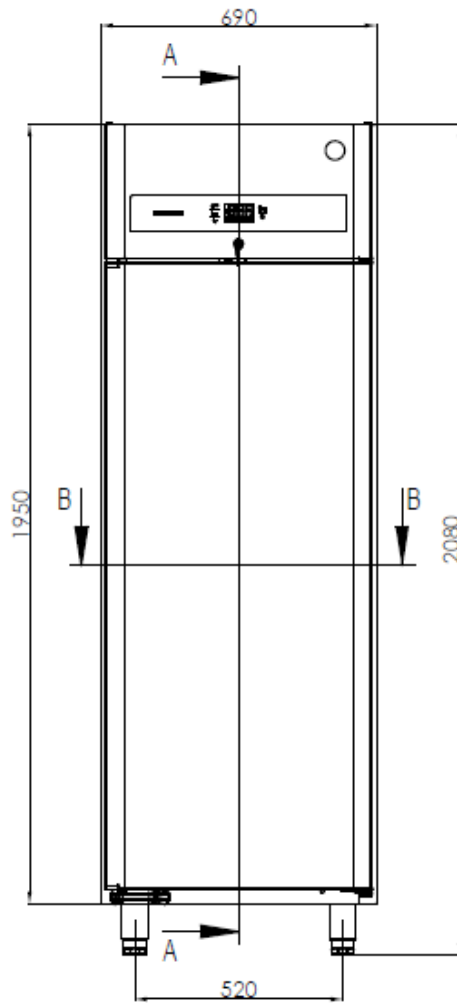

A-A

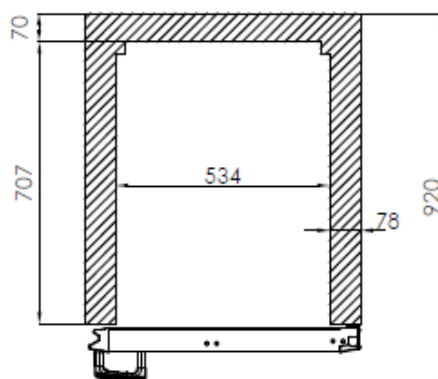

B-B

HOSHIZAKI

Premier Remote Cabinets



PREMIER U 60

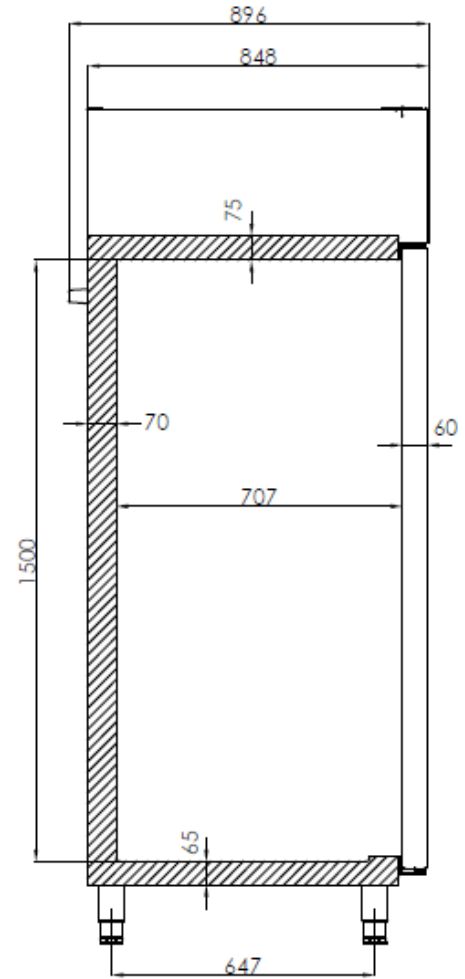
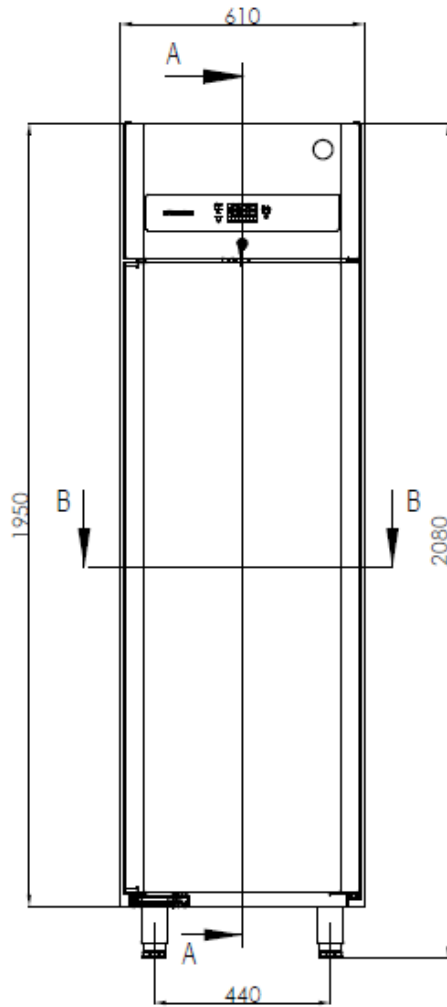

A-A

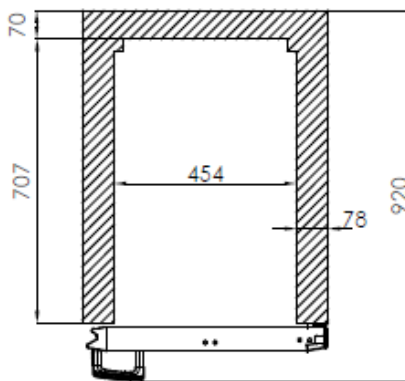

B-B

HOSHIZAKI

Premier Remote Cabinets



PREMIER U 80

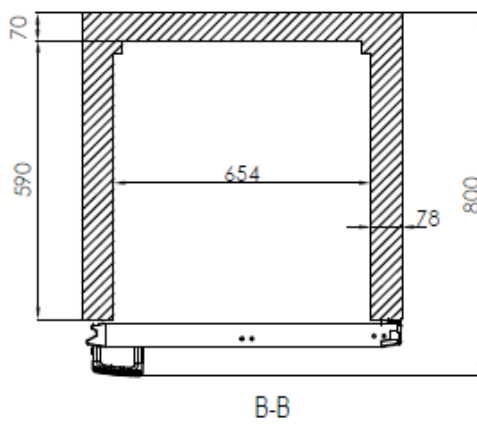
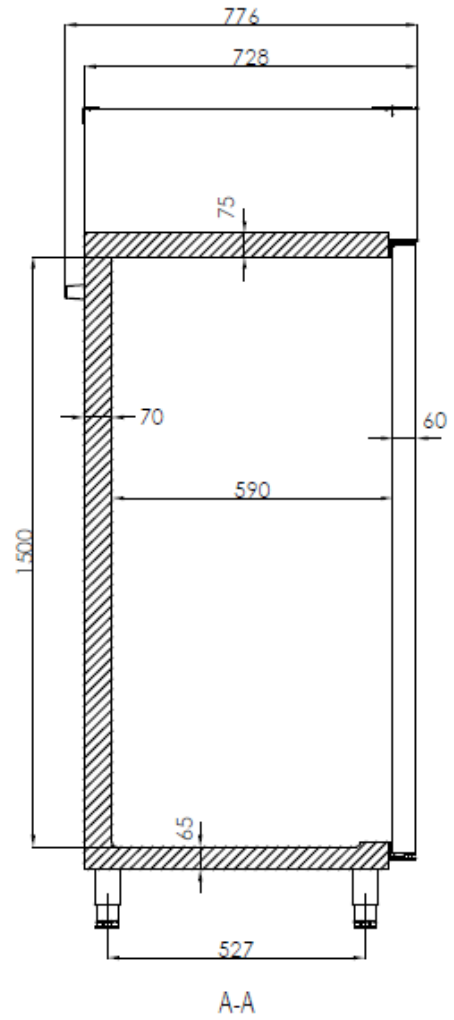
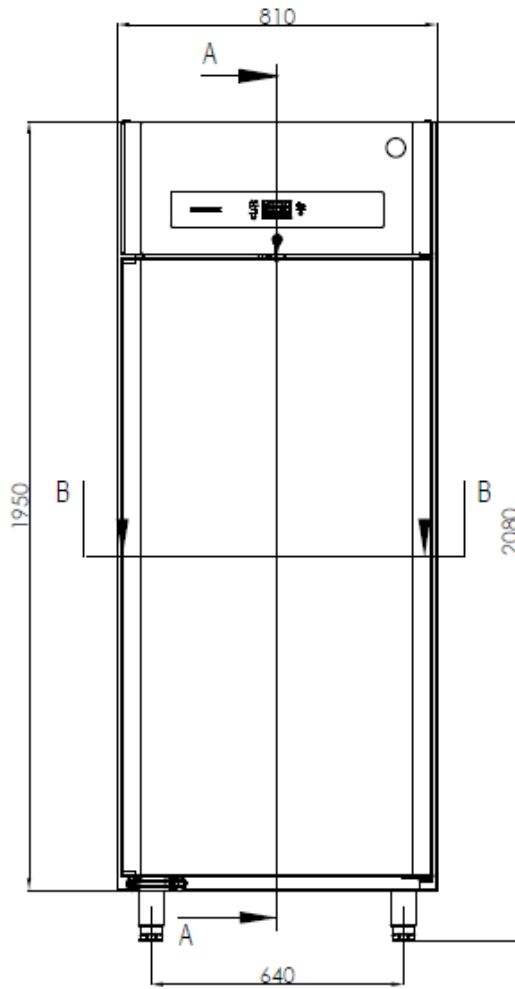

HOSHIZAKI

Premier Remote Cabinets



PREMIER U 140

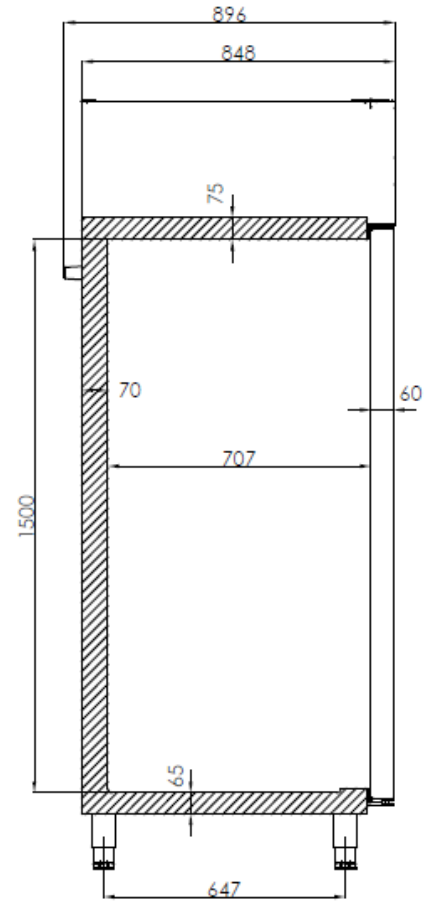
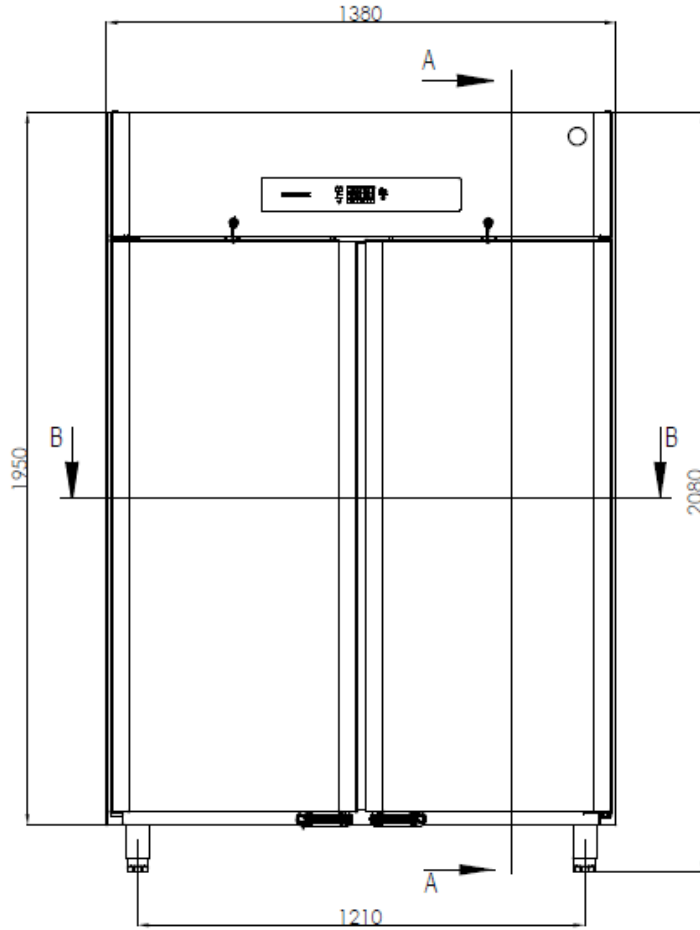

A-A

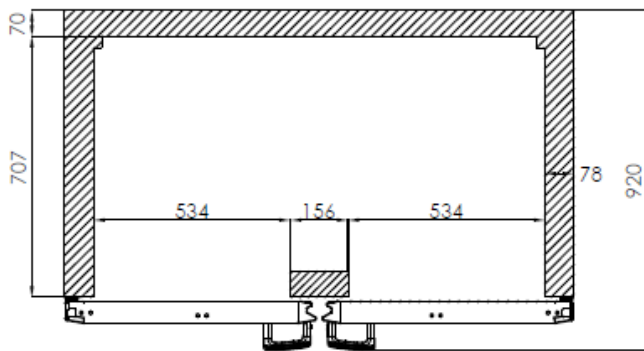

B-B

HOSHIZAKI

Premier Remote Cabinets



BAKER U 950

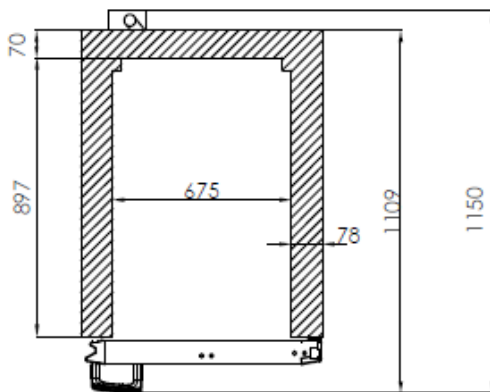
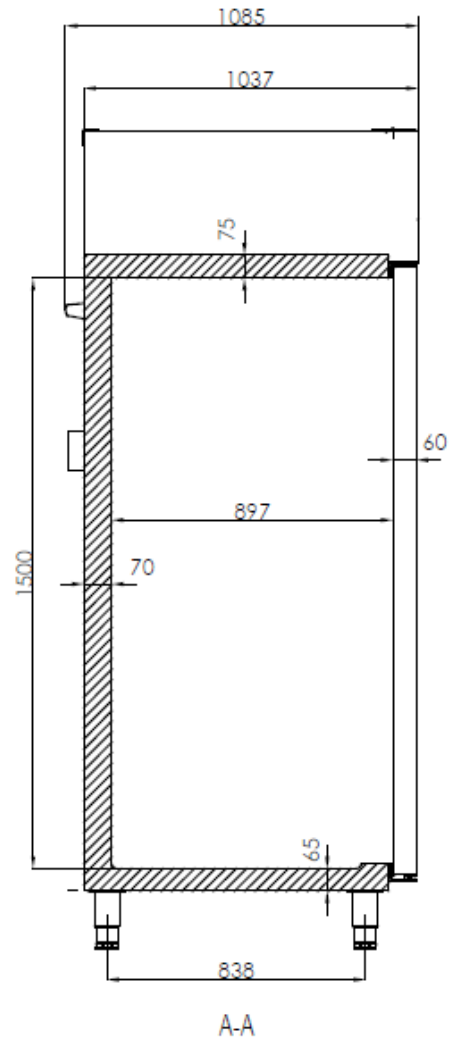
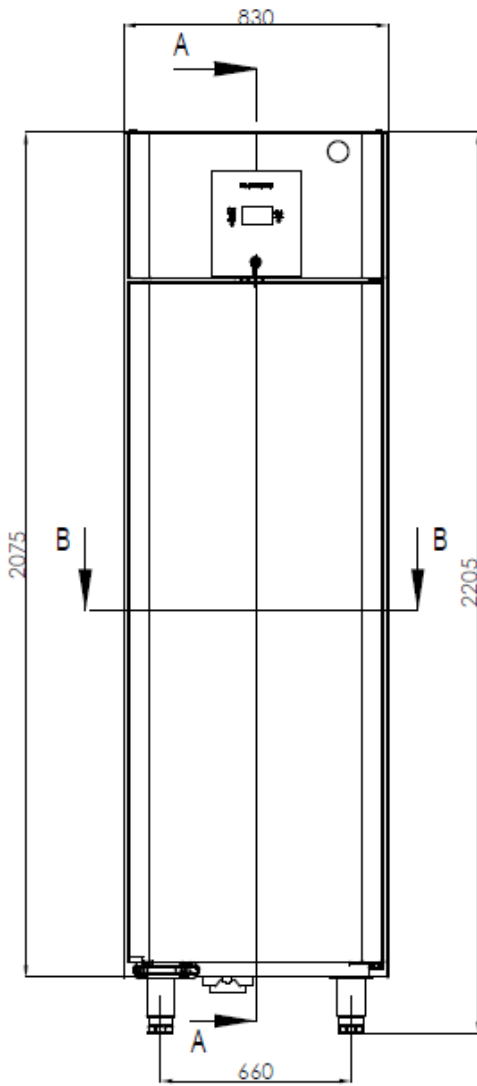

HOSHIZAKI

Premier Remote Cabinets



BAKER GA 950 (RU1)

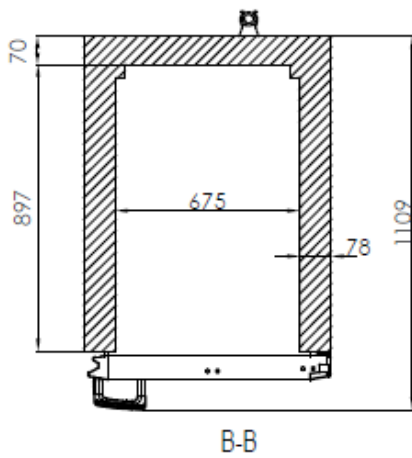
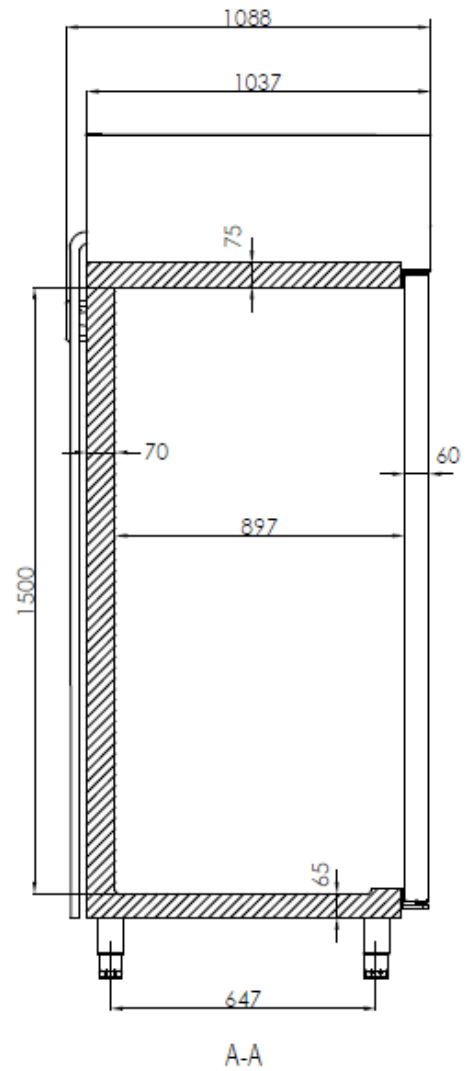
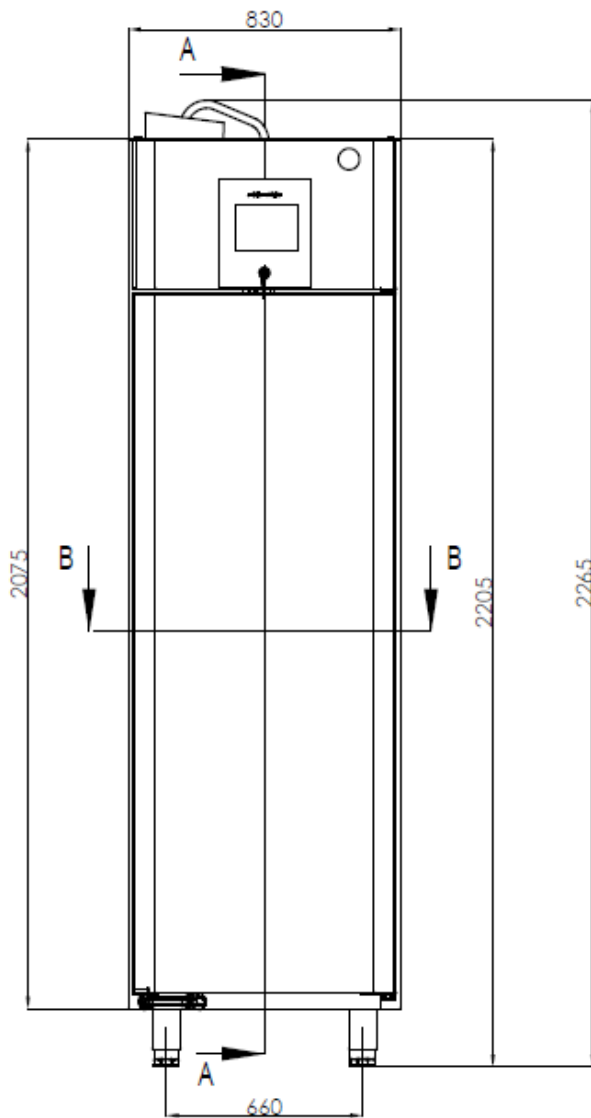

HOSHIZAKI

Premier Remote Cabinets



BAKER SF 950 (RU1)

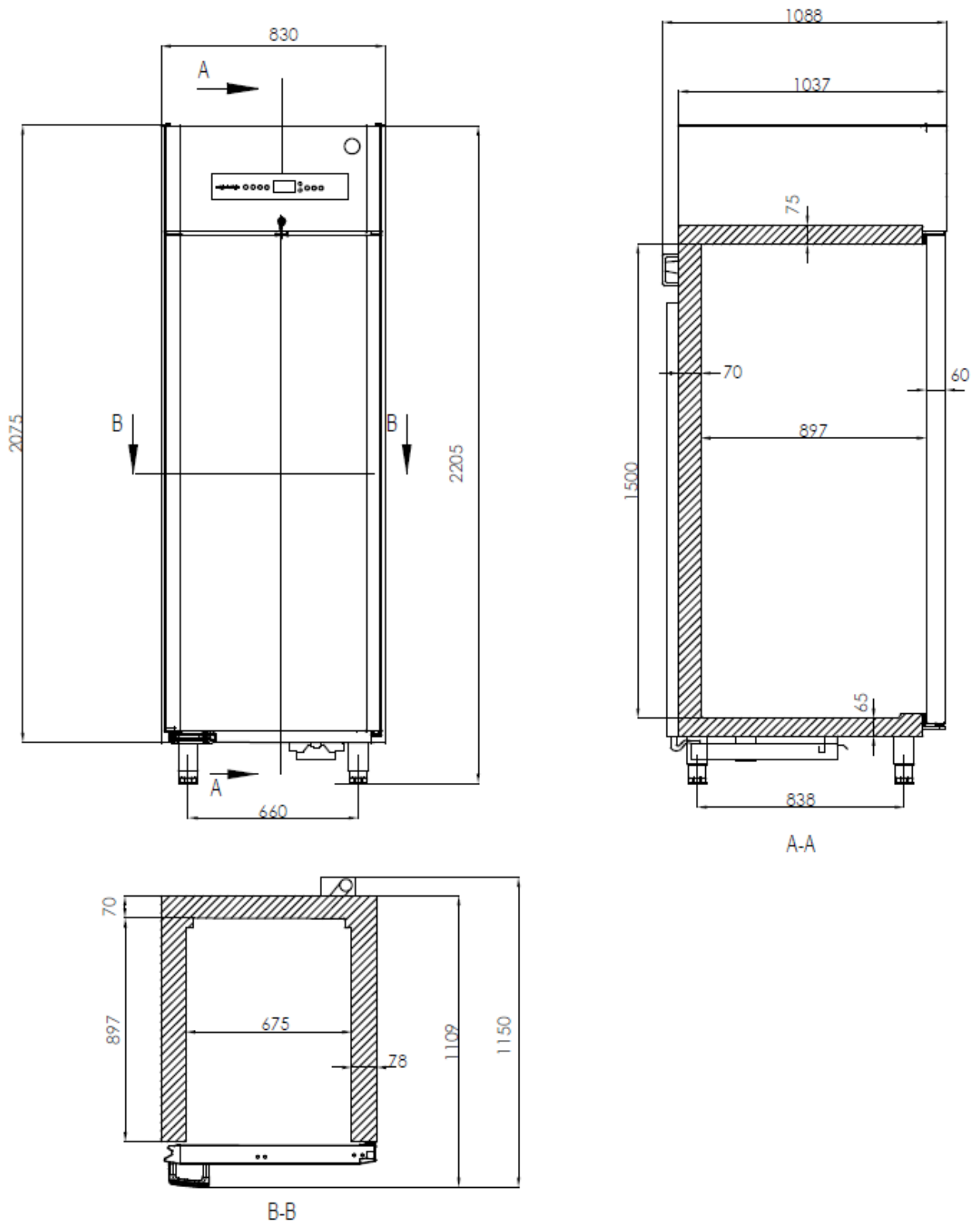

Bortskaffelse

Nedenstående gælder kun for Storbritannien.

Vi bortskaffer kun et gammelt skab, når vi samtidig leverer et nyt. Skabene skal være helt afrimede og tømt før afhentning.

Hoshizaki anerkender, at vores produkter til cateringmarkedet betragtes som WEEE, når de bliver forældede. For at sikre, at Hoshizakis ansvar håndteres korrekt og miljøvenligt, er vi tilmeldt den største Business to Business compliance-ordning i Storbritannien – B2B Compliance <http://www.b2bcompliance.org.uk>

B2B Compliance vil på vores vegne håndtere alle områder af vores ansvar, når vi indsamler og bortskaffer udstyr, der er underlagt de britiske WEEE-regler. B2B Compliance kan kontaktes på telefonnummer +44 01691 676124.



Ledningsdiagrammer

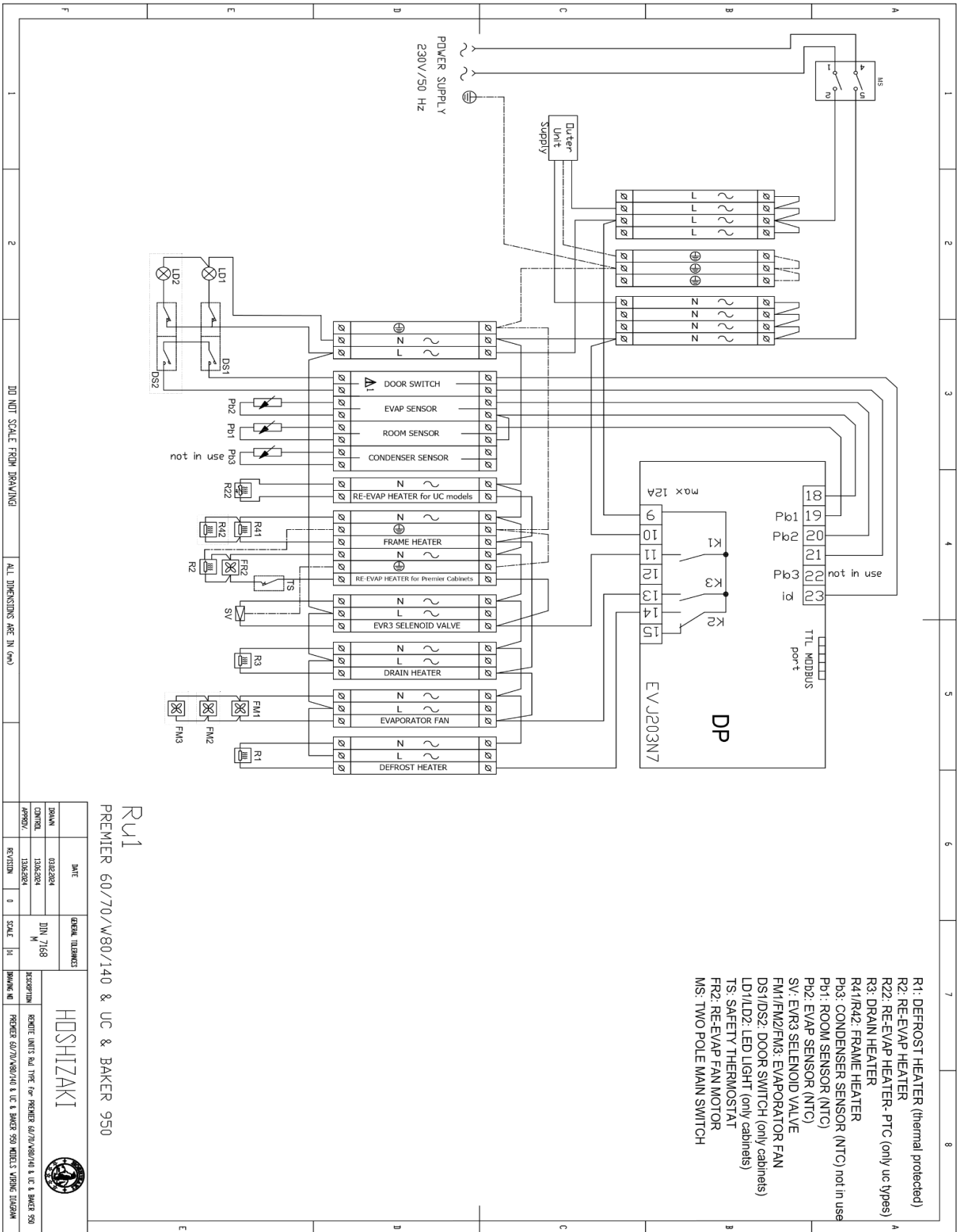

DATE		GENERAL DIMENSIONS		DESCRIPTION	DRAWING NO
DRAWN	03/02/2014	DIN	7168		
CONTROL	13/02/2014	M			
APPROV.	13/02/2014				
REVISION	0	SCALE	1:1		

HOSHIZAKI Premier Remote Cabinets

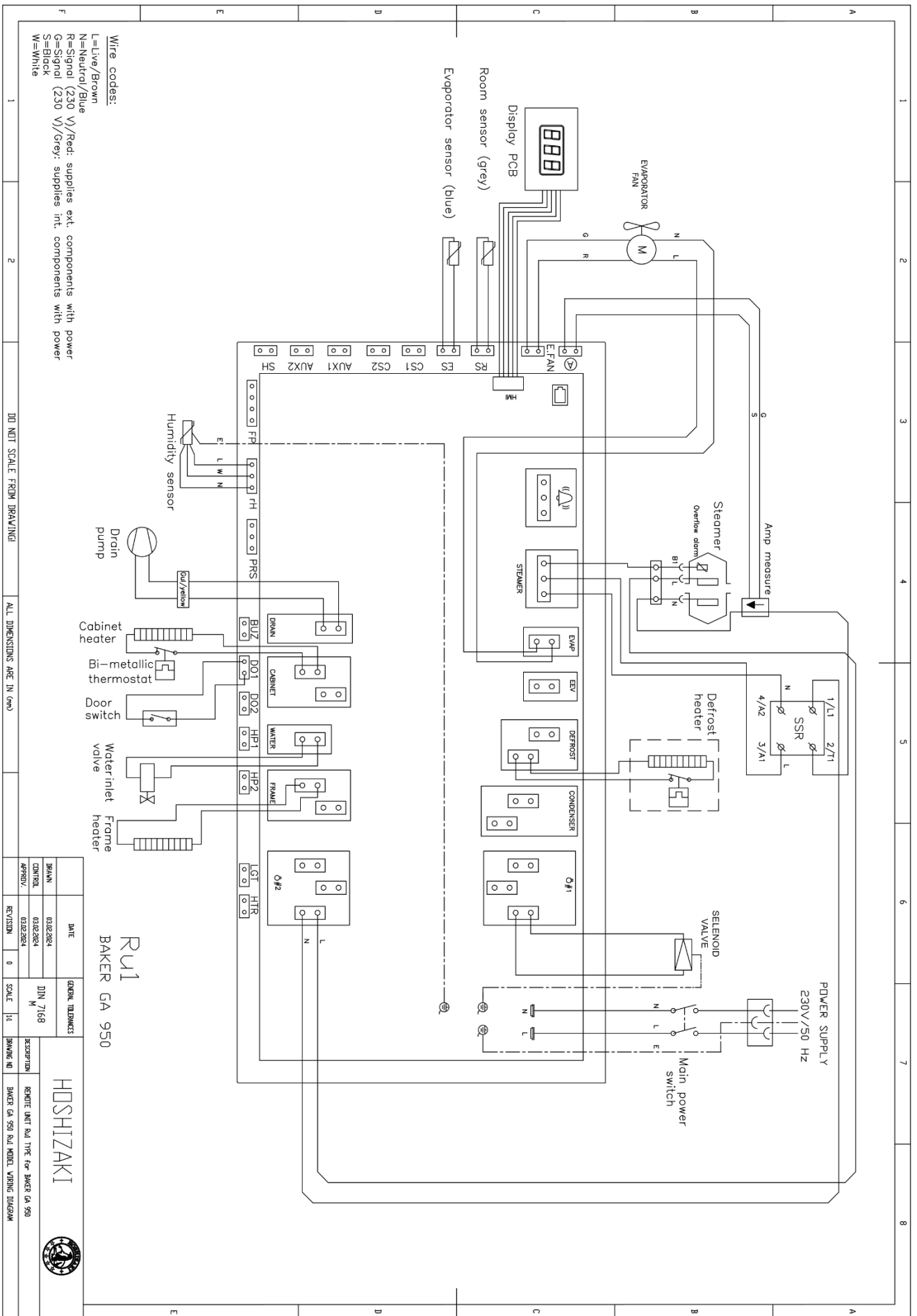

HOSHIZAKI Premier Remote Cabinets

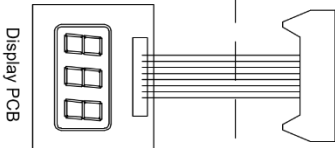
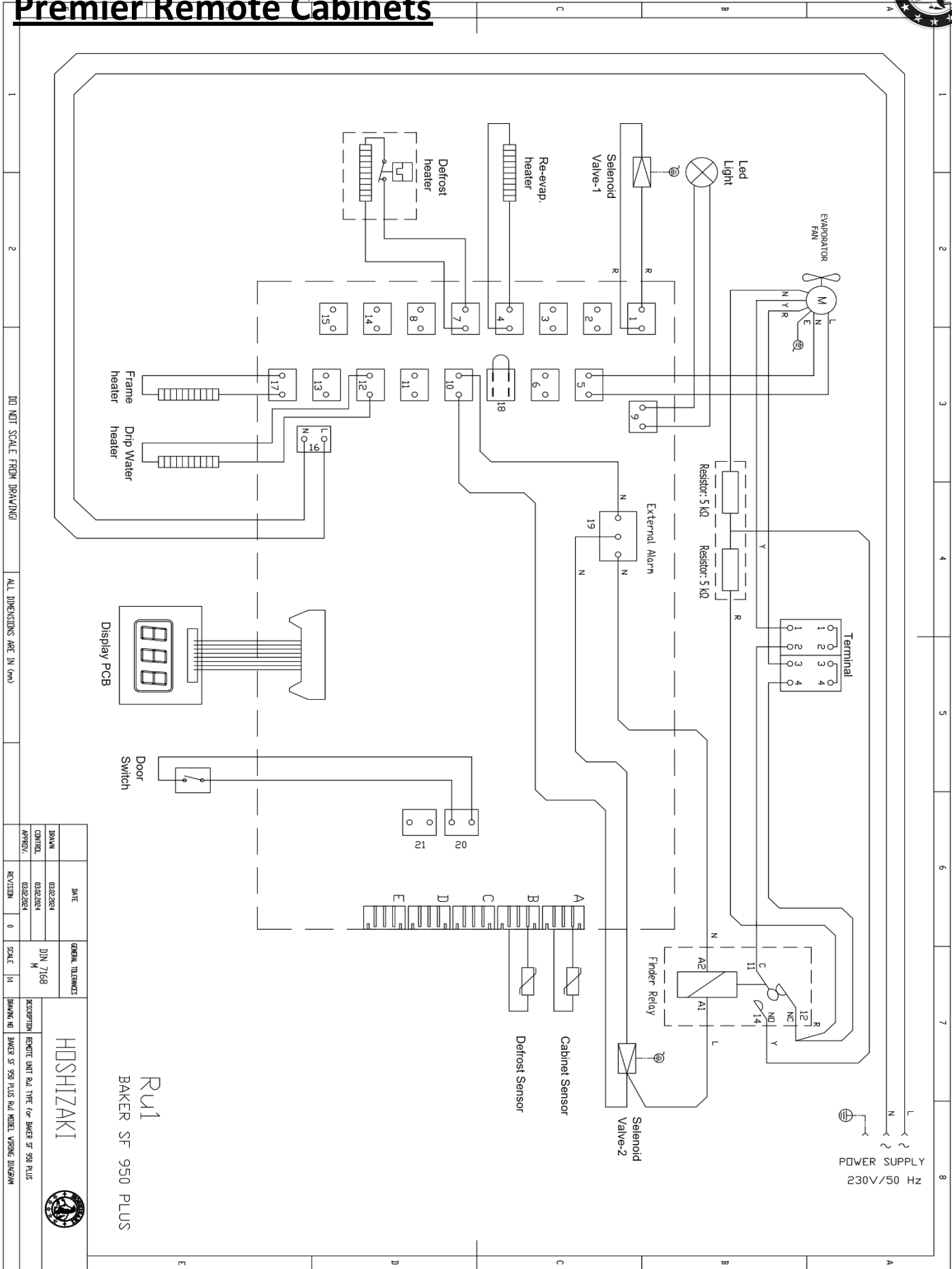

Ru1
BAKER SF 950 PLUS

ALL DIMENSIONS ARE IN (mm)

DATE	GENERAL DIMENSIONS	DESCRIPTION
03/28/2014	DIN 7168	REMOTE UNIT BUL TYPE FOR BAKER SF 950 PLUS
03/28/2014	M	BAKER SF 950 PLUS BUL MODEL VARIANS DIAGRAM
03/28/2014		
0	SCALE 1:1	



HOSHIZAKI Premier Remote Cabinets

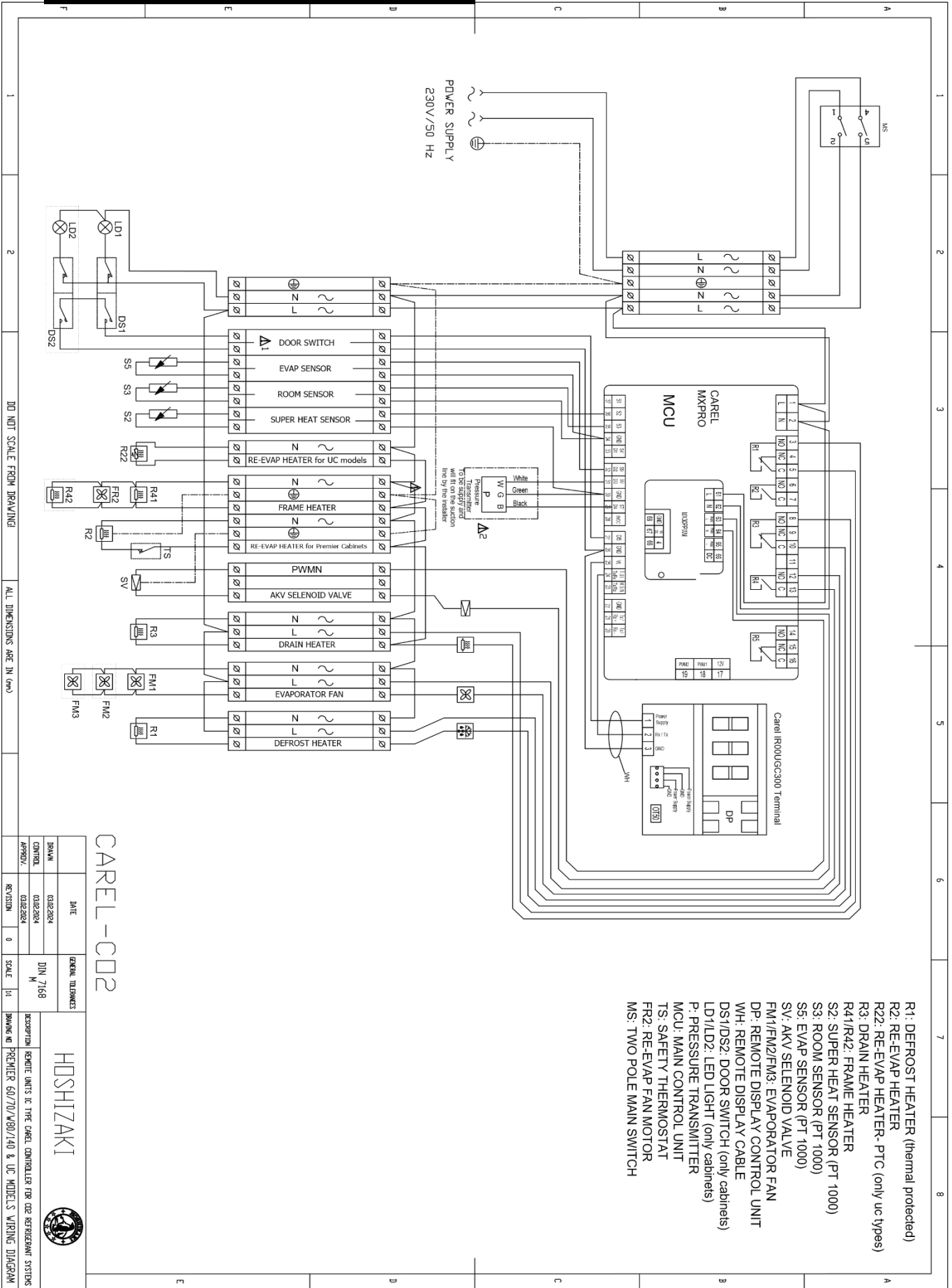

- R1: DEFROST HEATER (thermal protected)
- R2: RE-EVAP HEATER
- R22: RE-EVAP HEATER- PTC (only uc types)
- R3: DRAIN HEATER
- R41/R42: FRAME HEATER
- S2: SUPER HEAT SENSOR (PT 1000)
- S3: ROOM SENSOR (PT 1000)
- S5: EVAP SENSOR (PT 1000)
- SV: AKV SELENOID VALVE
- FM1/FM2/FM3: EVAPORATOR FAN
- DP: REMOTE DISPLAY CABLE
- WH: REMOTE DISPLAY CABLE
- DS1/DS2: DOOR SWITCH (only cabinets)
- LD1/LD2: LED LIGHT (only cabinets)
- P: PRESSURE TRANSMITTER
- MCU: MAIN CONTROL UNIT
- TS: SAFETY THERMOSTAT
- FR2: RE-EVAP FAN MOTOR
- MS: TWO POLE MAIN SWITCH

CAREL-CD2

DATE		GENERAL TOLERANCES	
DATE	03/02/2014	DIN 7168	M
REV. NO.	03/02/2014	SCALE	1:1
REVISION	0	DESCRIPTION: REMOTE UNITS IC THE CAREL CONTROLLER FOR C2 REFRIGERANT SYSTEMS	
DRAWING NO: PREMIER 60/70/V80/140 & UC MODELS WIRING DIAGRAM			



HOSHIZAKI Premier Remote Cabinets

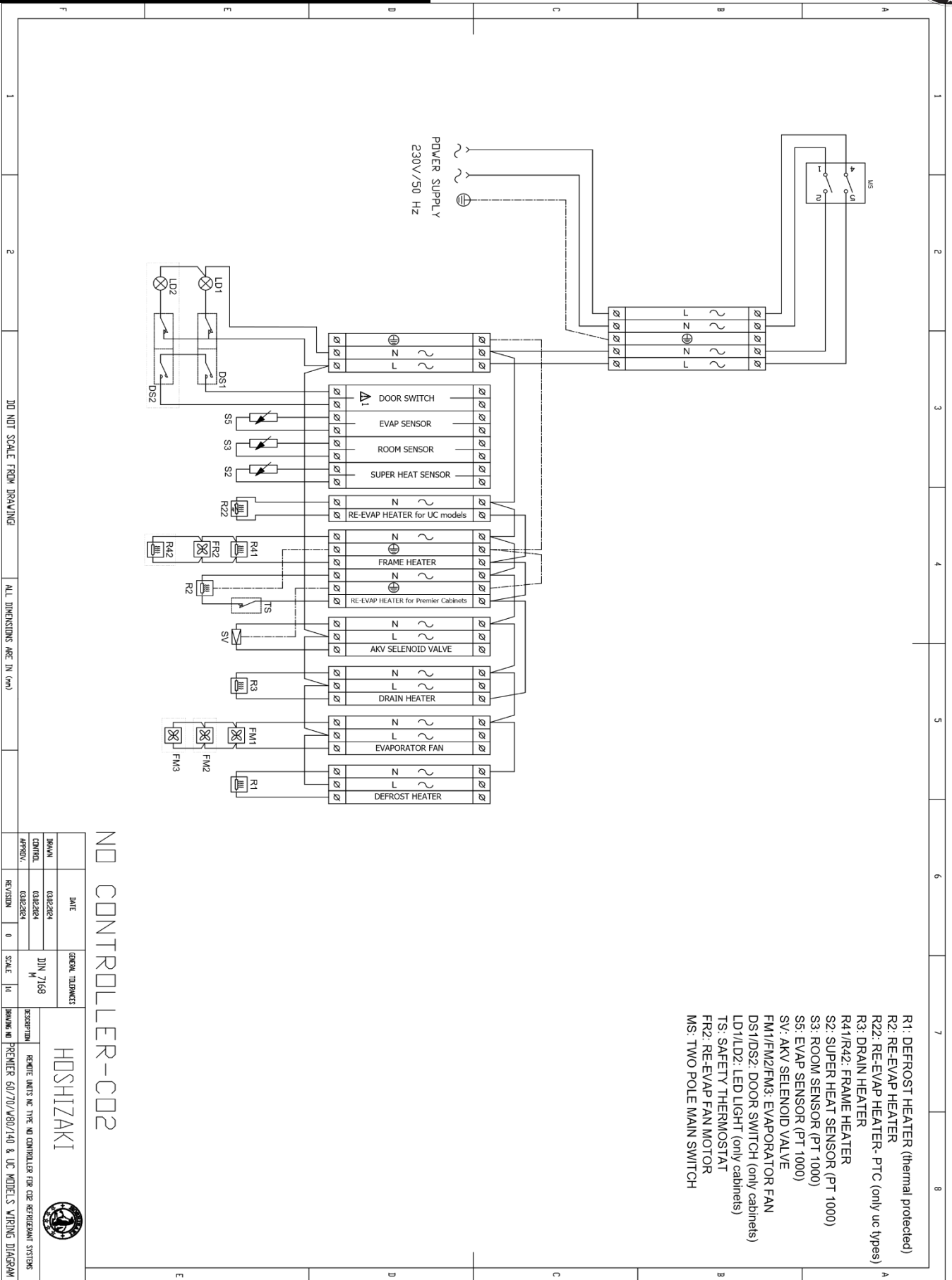

- R1: DEFROST HEATER (thermal protected)
- R2: RE-EVAP HEATER
- R22: RE-EVAP HEATER- PTC (only uc types)
- R3: DRAIN HEATER
- R41/R42: FRAME HEATER
- S2: SUPER HEAT SENSOR (PT 1000)
- S3: ROOM SENSOR (PT 1000)
- S5: EVAP SENSOR (PT 1000)
- SV: AKV SELENOID VALVE
- FM1/FM2/FM3: EVAPORATOR FAN
- DS1/DS2: DOOR SWITCH (only cabinets)
- LD1/LD2: LED LIGHT (only cabinets)
- TS: SAFETY THERMOSTAT
- FR2: RE-EVAP FAN MOTOR
- MS: TWO POLE MAIN SWITCH

NO CONTROLLER-C02

GENERAL TOLERANCES		DATE	
BRAIN	03/28/2014	DATE	03/28/2014
CONTROL	03/28/2014	DATE	03/28/2014
APPROV.		DATE	
REVISION	0	SCALE	1:1

DIN 7168
M

HOSHIZAKI

REMOTE UNITS NC TYPE NO CONTROLLER FOR CO2 REFRIGERANT SYSTEMS

DRAWING NO PREMIER 60/70/80/140 & UC MODELS WIRING DIAGRAM

DO NOT SCALE FROM DRAWING ALL DIMENSIONS ARE IN (mm)

1

2

3

4

5

6

7

8

HOSHIZAKI

Premier Remote Cabinets



Kølediagrammer

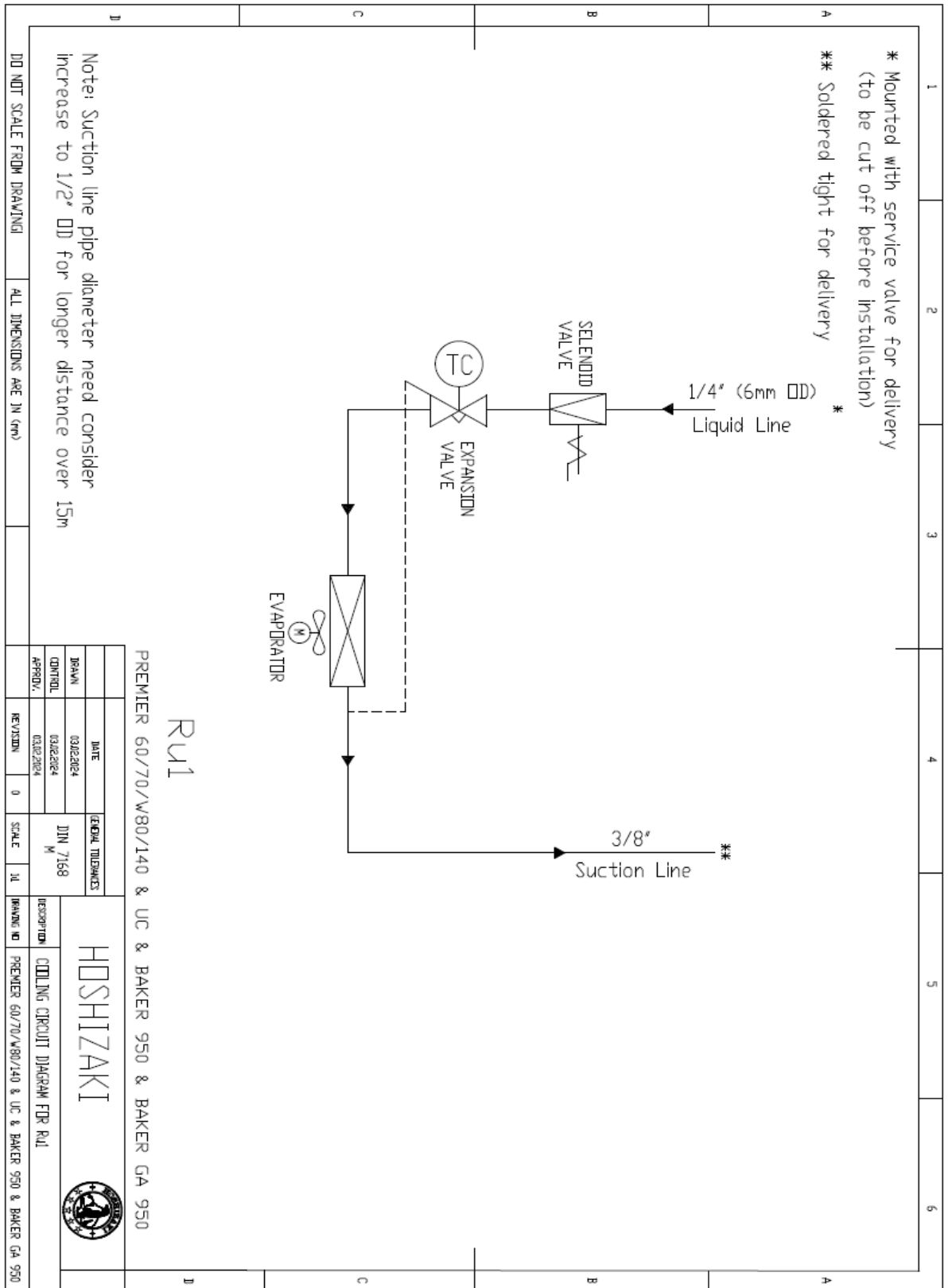

HOSHIZAKI

Premier Remote Cabinets

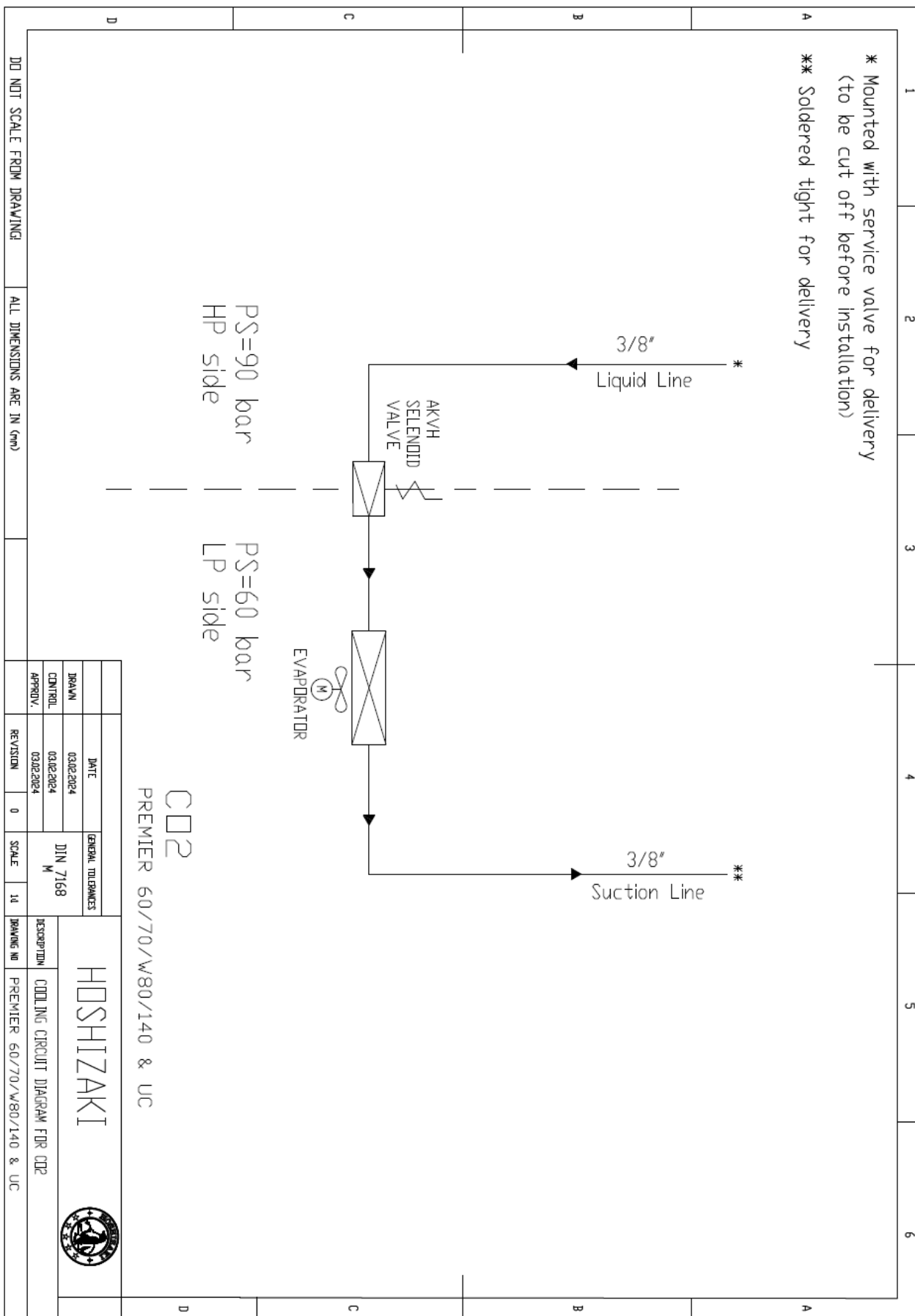

HOSHIZAKI

Premier Remote Cabinets



Hoshizaki forbeholder sig retten til at ændre alle funktioner og oplysninger i denne vejledning.

Kontaktoplysninger

Hovedkvarter

Hoshizaki Europe B.V.

TLF.: +31 20 691

8499

Sales@hoshizaki.nl

<http://hoshizaki->

[europe.com/](http://hoshizaki-europe.com/)

Filialer

Hoshizaki UK - Storbritannien, Irland

TLF.: +44 845 456 0585

uksales@hoshizaki.co.uk

Hoshizaki Deutschland - Tyskland, Schweiz, Østrig

TLF.: +49 2154 92810, +49 5066 604612

info@hoshizaki.de

Hoshizaki BENELUX - Holland, Belgien, Luxembourg

TLF.: +31 20 565 0420, +31 54 645 4252

sales@hoshizaki.nl

Hoshizaki France - Frankrig

TLF.: +33 1 48 63 93 80

info@hoshizaki.fr

Hoshizaki Iberia - Spanien, Portugal

TLF.: +34 93 478 09 52

info@hoshizaki.es

Hoshizaki Middle East - Mellemøsten

TLF.: +971 48 876 612

sales@hoshizaki.ae

Hoshizaki Danmark – Danmark, Norge, Sverige

TLF.: +45 8988 5350

salg@hoshizaki.dk

Hoshizaki Europe B.V – alle andre lande i Europa og Afrika

TLF.: +31 20 565 0420

sales@hoshizaki.nl

HOSHIZAKI

Premier Remote Cabinets



HOSHIZAKI

Premier Remote Cabinets



MODELLI RU1 E CO2 COMANDATI A DISTANZA MANUALE DI INSTALLAZIONE, USO E MANUTENZIONE



Dettagli del contatto:
HOSHIZAKI EUROPE B.V.
Indirizzo: Burgemeester Stramanweg 101 1101 AA Amsterdam, Paesi Bassi
Tel: +31 (0)20 691 84 99 - <http://hoshizaki-europe.com/>





Contenuto

Applicazione	255
Informazioni di sicurezza	256
Ubicazione.....	257
Collegamento elettrico.....	259
Uso generale	260
Uso del prodotto (Controller Evco - Modello RU1).....	261
Uso del prodotto (Controller Danfoss AK - CC55)	262
Uso del prodotto (Controller Carel MPXpro).....	265
Uso del prodotto (Nessun controller - Modello NC)	271
Risoluzione dei problemi	271
Acqua di sbrinamento.....	272
Meccanismo di chiusura della porta	272
Interruzione di corrente.....	272
Pulizia.....	272
Guarnizioni della porta.....	273
Conservazione a lungo termine.....	273
Assistenza	273
Dati tecnici.....	274
Dimensioni.....	276
Smaltimento.....	283
Schemi elettrici	284
Schemi di raffreddamento	290



Grazie per aver scelto un prodotto di qualità di Hoshizaki.

Il presente manuale fornisce indicazioni su come installare, utilizzare e mantenere il nuovo prodotto.

Prima che i nostri prodotti lascino la fabbrica, vengono sottoposti a un test completo di funzionalità e qualità. Se ciononostante si riscontrassero problemi con il prodotto, contattare il rivenditore locale.

Le filiali e i rivenditori di Hoshizaki in tutto il mondo sono a vostra disposizione per aiutarvi.

I prodotti fabbricati da Hoshizaki sono coperti da diverse condizioni di garanzia a seconda del Paese in cui il prodotto è venduto.

Questa garanzia è soggetta all'utilizzo corretto secondo le specifiche che prevede, ad esempio, l'esecuzione della manutenzione ordinaria e delle eventuali riparazioni da tecnici designati dal rivenditore e con una conoscenza generale del prodotto.

Modifiche nell'installazione e usi del prodotto diversi da quelli specificati nel presente manuale potrebbero influire sul funzionamento e sulla durata del prodotto.

Il manuale è scritto in base alle nostre attuali conoscenze tecniche. Lavoriamo continuamente all'aggiornamento di queste informazioni e ci riserviamo il diritto di apportare modifiche tecniche.

Applicazione

Il prodotto è destinato alla conservazione di alimenti in ambienti non domestici.

Il prodotto è progettato per conservare gli alimenti a una temperatura costante e non può essere utilizzato per raffreddare o congelare alimenti caldi/freschi.

Il prodotto deve essere utilizzato esclusivamente per gli impieghi per il quale è stato espressamente progettato. Qualsiasi altro uso potrebbe impedire il mantenimento alla temperatura corretta degli alimenti conservati nel prodotto o addirittura danneggiare il prodotto.

Il prodotto non è adatto per la conservazione di plasma sanguigno, campioni di laboratorio, farmaci o sostanze simili.

La casa costruttrice declina ogni responsabilità per eventuali danni provocati da uso improprio, non corretto o sconsiderato del prodotto.

Informazioni di sicurezza

Importante

Descrizione dei simboli utilizzati nel presente manuale.



Avvertenza L'inosservanza di queste istruzioni potrebbe causare incidenti con lesioni personali.



Importante Se non si rispettano queste istruzioni, si rischia di danneggiare o distruggere il prodotto.

Tenere presente che Hoshizaki ha adottato precauzioni per garantire che la sicurezza del prodotto sia in regola.

Leggere attentamente le seguenti informazioni relative alla sicurezza.



È importante che tutti coloro che devono utilizzare o installare il prodotto abbiano accesso a questo manuale.



Questa macchina non deve essere utilizzata da persone con capacità fisiche, sensoriali e mentali ridotte o prive dell'esperienza e della conoscenza necessarie, tranne nei casi in cui siano fornite la supervisione o le istruzioni relative all'utilizzo della macchina da una persona responsabile della sicurezza.



È necessaria la supervisione di un adulto per assicurare che i bambini non giochino con la macchina.



La macchina può contenere parti con spigoli vivi nello scomparto del compressore e nello scomparto interno.



La macchina non deve essere trasportata su carrelli; c'è il rischio di perdere l'equilibrio, mettendo in pericolo le persone.



Non tirare il cavo di alimentazione per scollegare la macchina o quando si sposta la macchina.

Ubicazione

Quando si riceve il prodotto, controllare l'integrità del materiale di imballaggio.

Se il materiale di imballaggio si danneggia, occorre valutare se anche il prodotto potrebbe essersi danneggiato. Se il danno è notevole, contattare il rivenditore.



Questa operazione richiede almeno 2 persone. La parte più pesante del prodotto è nella parte superiore. Tenerne conto quando si rimuove il pallet di trasporto.



A causa del peso elevato del prodotto, il pavimento potrebbe danneggiarsi o graffiarsi quando si sposta il prodotto.



L'installazione corretta consente il funzionamento ottimale.



Il prodotto deve essere ubicato in un locale asciutto e adeguatamente ventilato.



Per garantirne il funzionamento efficiente, esso non deve essere esposto alla luce diretta del sole o posizionato a contatto con superfici che emettono calore. Il prodotto è progettato per funzionare a una temperatura ambiente compresa tra +16 °C e +40 °C.



Evitare di collocare il prodotto in ambienti contenenti cloro/acido (piscine, ecc.) a causa del rischio di corrosione.



Il prodotto e le parti all'interno sono dotati di una pellicola protettiva che deve essere rimossa prima dell'uso.



Pulire il prodotto con una soluzione di sapone neutro prima dell'uso.

Il prodotto deve essere installato su una superficie piana e orizzontale.

Per le versioni con gambe, utilizzare le gambe regolabili per garantire che il prodotto stia in piano e diritto.

Per le versioni con rotelle, occorre attivare i dispositivi di bloccaggio delle due rotelle anteriori quando il prodotto è in posizione.

HOSHIZAKI

Premier Remote Cabinets



Devono sempre esserci 500 mm di spazio libero sopra il prodotto, per consentire gli interventi di assistenza e manutenzione. Il prodotto deve essere posizionato il più vicino possibile alla parete.

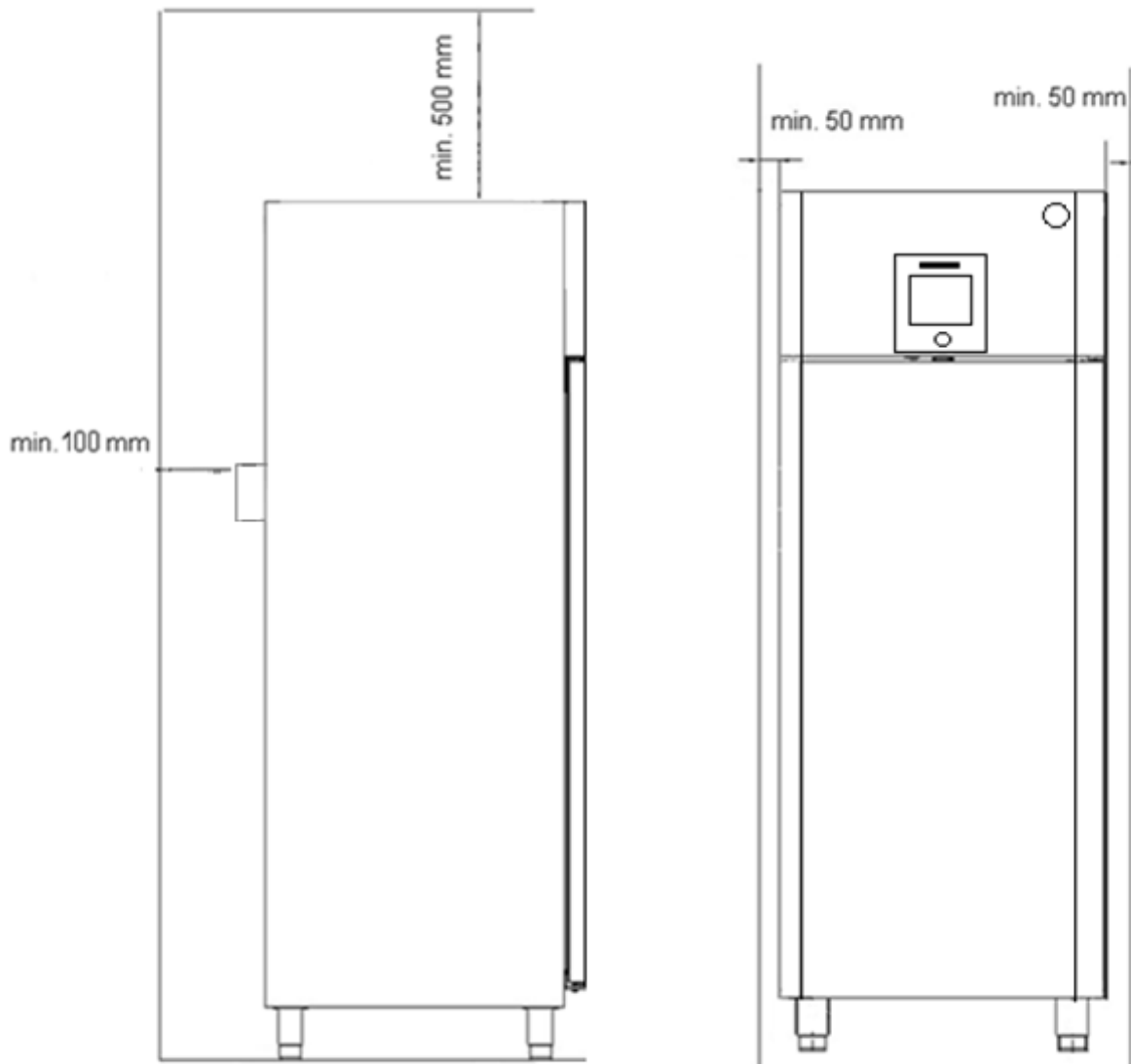

Collegamento elettrico

Leggere attentamente il testo sottostante prima di eseguire il collegamento elettrico.



Il prodotto è destinato a essere collegato alla corrente alternata. La tensione (V) e la frequenza (Hz) di collegamento sono indicate sulla targhetta dell'armadio frigo



Mai usare prolunghe per questa macchina!

Se una presa a muro si trova a una distanza superiore alla lunghezza del cavo di alimentazione fornito, contattare un elettricista per installare una presa a muro entro la lunghezza del cavo di alimentazione.



Se il prodotto è difettoso, **deve essere esaminato da un tecnico dell'assistenza qualificato** che abbia dimestichezza con l'unità di controllo installata e abbia esperienza nella manutenzione dell'armadio frigo modello CO2.



In generale, deve essere esaminato dall'azienda che ha collegato il prodotto.



Scollegare sempre l'alimentazione se si verificano interruzioni dell'alimentazione elettrica, quando si rimuovono/installano le parti elettriche e prima di pulire e mantenere il prodotto.



Non utilizzare il prodotto senza tutte le parti protettive installate per evitare di toccare parti della macchina sotto tensione o rotanti



Il prodotto non deve essere utilizzato all'aperto.

Devono essere soddisfatti tutti i requisiti di messa a terra prescritti dalle autorità elettriche locali. La spina e la presa a muro devono quindi assicurare una messa a terra adeguata. Se necessario, consultare un elettricista.



Verificare che il prodotto sia spento dalla presa o che la spina tripolare sia scollegata prima di intervenire sulle parti elettriche. Non è sufficiente spegnere il prodotto dal controller.

Uso generale



Non danneggiare le parti del sistema refrigerante.



Se il prodotto è munito di un vassoio di rievaporazione sotto l'armadio frigo, è importante non effettuare manutenzione e non pulire il vassoio o il riscaldatore prima che l'armadio frigo sia stato spento per un tempo adeguato, in modo da garantire che il riscaldatore di rievaporazione si sia raffreddato e prevenire il rischio di ustioni.



Non utilizzare dispositivi elettrici all'interno del prodotto.



Per garantire un flusso d'aria adeguato nell'armadio frigo, tenere le aree designate libere da qualsiasi oggetto.



Tutti i prodotti da conservare non confezionati o imballati devono essere coperti per evitare un'inutile corrosione delle parti interne dell'armadio frigo.



Modificando i parametri del controller rispetto ai valori predefiniti, si rischia di causare il funzionamento anomalo del prodotto con temperature pericolose che potrebbero danneggiare i prodotti conservati all'interno del prodotto.



Carico massimo del ripiano: 40 kg



Non conservare sostanze esplosive, come bombolette spray contenenti propellente infiammabile, all'interno di questa macchina.



Non collocare prodotti al di sotto del supporto del ripiano inferiore o sopra il contrassegno della linea di carico superiore.

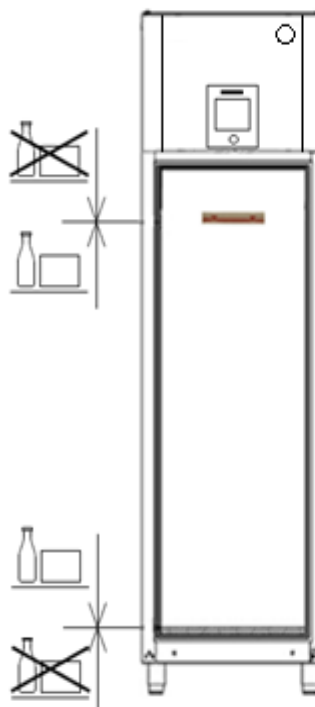

Do not store goods above the top loading mark

Do not store goods below the bottom grate

Uso del prodotto (Controller Evco - Modello RU1)

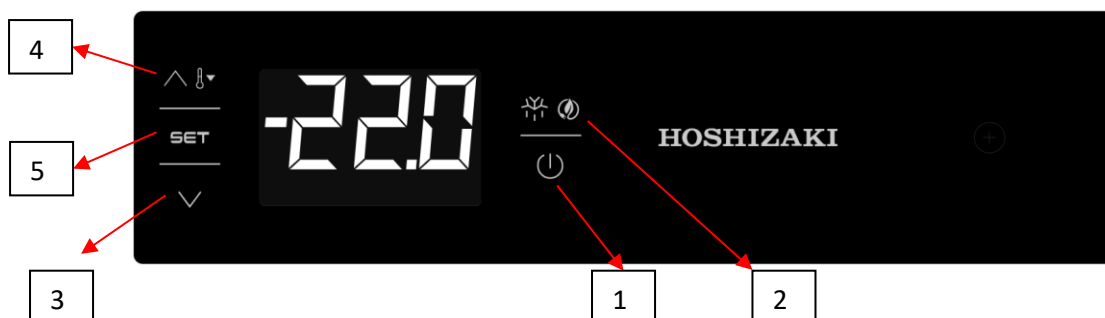

➤ FUNZIONI DEL PANNELLO ANTERIORE

Per bloccare i tasti del pannello anteriore, tieni premuto AUX (3) e On / Stand By (1) per 2 secondi: quando i tasti sono bloccati, sullo schermo apparirà il testo “Loc”; se non è bloccato, apparirà il testo “UnL”.

- 1) Tenendo premuto **ON/STAND BY** per 4 secondi, il dispositivo si apre o si chiude. (On/Off)
- 2) **SBRINAMENTO MANUALE**; se il pulsante viene premuto per 4 secondi, inizia lo sbrinamento manuale. Se è attivo il raffreddamento eccessivo e la temperatura dell'evaporatore non è adatta, lo sbrinamento manuale non si avvia.
- 3) Freccia **GIÙ**: scorrere verso il basso il menu o ridurre il valore; se tenuto premuto per 4 secondi, si attiva il super raffreddamento. Quando una funzione di raffreddamento eccessivo è attiva, la temperatura impostata può essere ridotta; il tempo e la temperatura sono determinati in base ai parametri. Quando una funzione di raffreddamento eccessivo è attivata, la macchina non si sbrina mai.
- 4) Freccia **SU**: scorrere verso l'alto il menu o aumentare il valore; se tenuto premuto per 4 secondi, si attiva la percentuale di funzione di umidità relativa bassa e alta. (Per alcuni modelli) sullo schermo compare “rhL” (è in funzione una bassa percentuale di funzione di umidità relativa) o “rhH” (è in funzione una percentuale di funzione di umidità relativa alta). Queste funzioni appaiono sullo schermo per 10 secondi. Se il controllo dell'umidità non è disponibile, sullo schermo appare “----” per 1 secondo.
- 5) Tasto **SET**: tasto di inserimento e modifica dei valori regolabili.

➤ FUNZIONAMENTO

I casi di funzionamento sono disponibili qui sotto:

Stato **“On”**: il dispositivo è alimentato e funziona.

Stato **“Stand-By”**: il dispositivo è spento ma è ancora alimentato.

Stato **“Off”**: per spegnere il dispositivo, scollegare la spina dalla presa o spegnere il fusibile principale; il dispositivo è spento.

Premier Remote Cabinet Uso del prodotto (Controller Danfoss AK - CC55)

Avvio:

Collegare l'alimentazione elettrica alla macchina.

Verificare che l'interruttore principale a 2 poli sia acceso.

Descrizione del display (AK-UI55):

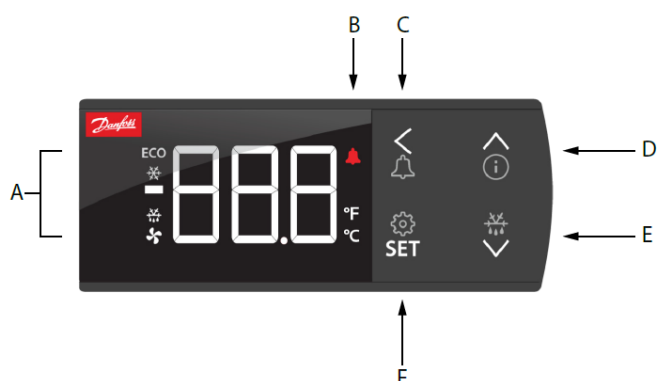

Parti del display	Descrizione
A	Si accende in caso di:  <ul style="list-style-type: none"> - Ottimizzazione energetica (ECO) - Raffreddamento - Sbrinamento - Funzionamento della ventola
B	Si accende in caso di allarme
C	Pressione prolungata (3 secondi) sul pulsante di allarme (il relè viene resettato); codice allarme visualizzato
D	La pressione prolungata (3 secondi) permette di accedere al menu informativo "InF" (Consultare la figura "b") Freccia Su/freccia Giù/Freccia Sinistra: navigazione nel menu e impostazione dei valori.
E	La pressione prolungata (3 secondi) avvia uno sbrinamento, sul display viene visualizzato "-d-". La pressione prolungata consente di interrompere lo sbrinamento in corso.
F	SET: la pressione prolungata (3 secondi) consente di accedere al menu "SET". Se l'operazione è bloccata con una password, viene visualizzato "PS". Digitare il codice. * Mostra l'impostazione per un parametro prescelto/salva un'impostazione modificata. La pressione breve permette di accedere al limite di spegnimento del termostato.

* L'impostazione di fabbrica di P89 è "0"; questo passaggio verrà saltato senza alcun valore di input.

HOSHIZAKI

Premier Remote Cabinets



a- Elenco parametri tasto "SET"

b - Elenco parametri tasto "Info"

SET	←	SET button, 3 s: Configuration settings
Set		
(PS) v	←	PS: Password (if any)
cFg	SET →	
v		
r--		
A--		
c--		
d--		
n--		
F--		
t--		
h--		
o--		
p--		
q--		
u--		
<		
(Return)		

r12	Main switch
o61	Application
o03	MODBUS address
r89	Food type
r00	Cut-out temperature
r15	Ther. sensor S4 %
r61	Ther. sensor S4% night
A36	Alarm sensor S4%
o17	Display air S4%
o30	Refrigerant type
o20	Min. transmitter range
o21	Max. transmitter range
d01	Defrost method
d03	Defrost interval
d10	Defrost sensor
d04	Max. defrost time
d02	Defrost stop temperature
<	
(Return)	

Menu groups
See also the following pages.

^	←	Info button, 3 s: Information for service use
Inf		
StA	SET	See control state message
App	SET	See selected application
in	SET →	
out	SET →	
buS	SET	MODBUS quality
SoF	SET	See SW version
<		
(Return)		

do1	*	Read output status
do2	*	
do3	*	
do4	*	
Ao1	**	
<		(Return)

AI1	(PE)	Read input status
AI2	**	
AI3	**	
AI4	**	
AI5	**	
di1	**	
di2	**	
<		(Return)

Output status
When you want info on a relay output, the dot will show whether the relay is activated (energized) for e.g.:
do4 = not activated
do.4 = activated

Messaggio di errore (allarmi)



In caso di errore, il LED di allarme sul pannello anteriore si accenderà e il relè di allarme verrà attivato (a seconda della priorità). Se si preme il pulsante di allarme per 3 secondi, è possibile visualizzare il report degli allarmi sul display.

Per ulteriori informazioni, consultare il manuale del controller CO2 selezionato.
(Danfoss AK-CC55 Compact)

Code	Alarm text	Description
E01	Hardware failure	The controller has a hardware failure
E06	Clock lost time	Clock has lost valid time
E20	Pe Evap. pressure A - Sensor error	Sensor signal is out of range. Please check the sensor for correct operation
E24	S2 Gas outlet A - Sensor error	Sensor signal is out of range. Please check the sensor for correct operation
E25	S3 Air ON evap. A - Sensor error	Sensor signal is out of range. Please check the sensor for correct operation
E26	S4 Air OFF evap. A - Sensor error	Sensor signal is out of range. Please check the sensor for correct operation
E27	S5 Evaporator A - Sensor error	Sensor signal is out of range. Please check the sensor for correct operation
A01	High temperature alarm A	The alarm temperature has been above the max alarm limit for a longer time period than the set alarm delay.
A02	Low temperature alarm A	The alarm temperature has been below the min alarm limit for a longer time period than the set alarm delay.
A04	Door open alarm	The door has been open for a too long time
A05	Max defrost hold time exceeded	The controller has been waiting longer time than permitted after a co-ordinated defrost.
A11	Refrigerant not selected	The refrigerant has not been selected hence control can not be initiated
A15	DI alarm 1	Alarm signal from digital input signal
A16	DI alarm 2	Alarm signal from digital input signal
A45	Main switch set OFF	The controller main switch has been set to either Stop or Manual control. Alternatively a digital input set up for "main switch" function, has stopped control
A59	Case in cleaning mode	A case cleaning operation has been started on a case
AA2	CO ₂ leak detected	CO ₂ is leaking from the refrigeration system
AA3	Refrigerant leak detected	Refrigerant is leaking from the refrigeration system
a04	Wrong IO configuration	Inputs and outputs have not been configured correctly

Usò del prodotto (Controller Carel MPXpro)

Avvio

Inserire l'alimentazione elettrica della macchina

L'impostazione predefinita del controller dell'armadio frigo è quella che risulta attivata alla consegna.

Ciò significa che il controller inizierà la regolazione quando si collega l'alimentazione elettrica e si mette l'interruttore principale nella posizione di accensione.

Accensione/spegnimento dell'armadio frigo

Per accendere/spegnere l'armadio frigo si utilizza l'interruttore principale a 2 poli sul lato sinistro della scatola di controllo principale, che si trova nello "scomparto del compressore".

Display

Layout/descrizione del display:





Il display sopra illustrato presenta una lettura a tre cifre.

All'interno dell'area di lettura si trovano vari LED. Questi LED forniscono le indicazioni elencate di seguito.

In generale = quando un LED lampeggia, l'attivazione è ritardata o limitata.

 = raffreddamento attivo (quando questo LED è acceso, il raffreddamento è attivo)

 = ventola interna in funzione (quando questo LED è acceso, la ventola interna/dell'evaporatore è accesa)

 = sbrinamento attivo (quando questo LED è acceso, è in corso un ciclo di sbrinamento)

 = se il LED lampeggia, indica l'apertura della porta o un allarme o errore in corso.

HACCP = quando questo LED è acceso, è in corso un allarme HACCP. Quando questo LED lampeggia, è presente un allarme HACCP salvato.

Tasti:

I 4 tasti posizionati sul lato destro del display servono ad accedere e regolare vari parametri. Questi tasti possono essere premuti da soli o in combinazione per far funzionare il controller.

Le impostazioni descritte di seguito sono le uniche che l'utente finale deve modificare. L'utente finale non deve modificare alcun parametro che non sia descritto in questa sezione. Tutte le altre impostazioni devono essere configurate da un tecnico qualificato.

IMPOSTAZIONI UTENTE

Regolazione del valore di impostazione della temperatura dell'armadio frigo



: UP



: DOWN



:Set



: Prg/mute

- Tenere premuto Set durante il normale funzionamento finché il display inizia a lampeggiare; il valore di impostazione della temperatura dell'armadio frigo può essere regolato con UP e DOWN.
- Quando il valore di impostazione è stato regolato sulla temperatura desiderata, si preme brevemente Set per salvare il nuovo valore e tornare al funzionamento normale.

Come eseguire uno sbrinamento manuale

- Per eseguire uno sbrinamento manuale, se la temperatura della sonda dell'evaporatore è sufficientemente fredda, tenere premuto def per più di 5 sec.
- Quando l'icona dello sbrinamento  è accesa, indica che è in corso uno sbrinamento.
- Se si tiene premuto def per più di 5 secondi quando è in corso un ciclo di sbrinamento, lo sbrinamento verrà disattivato.



Come disattivare gli allarmi acustici

- Quando il controller è in modalità di allarme, si sentirà un segnale acustico. L'allarme può essere silenziato premendo Prg/mute .

Impostazione dei limiti per gli allarmi di temperatura

- Tenere premuto Prg/mute per più di 5 secondi durante il normale funzionamento per aprire l'elenco dei parametri. Il display visualizzerà **/c1**
- Premere Prg/mute . Viene visualizzata la prima categoria di parametri, "Pro"
- Premere UP fino a raggiungere la categoria "ALn", indicata dall'icona  accesa sul display.
- Premere Set per visualizzare il parametro AA.
- Premere UP fino a raggiungere A1
- Premere Set per regolare se le impostazioni AL (**A**larm **L**ow temperature threshold, soglia di allarme temperatura bassa) e AH (**A**larm **H**igh temperature threshold, soglia di allarme temperatura alta) devono essere (0 = relative ai valori di impostazione della temperatura dell'armadio frigo) o (1 = assolute); impostazione predefinita = 1
- Premere Set per memorizzare l'impostazione scelta e tornare ad A1
- Premere UP fino a raggiungere AL (**A**larm **L**ow temperature threshold, soglia di allarme temperatura bassa)
- Premere Set per rendere possibile la regolazione di AL con UP e DOWN (regolabile tra -50 e +50); impostazione predefinita = -50 °C
- Premere Set per memorizzare l'impostazione scelta e tornare ad AL
- Premere UP fino a raggiungere AH (**A**larm **H**igh temperature threshold, soglia di allarme temperatura alta)
- Premere Set per rendere possibile la regolazione di AH con UP e DOWN (regolabile tra -50 e +50); impostazione predefinita = +50 °C
- Premere Set per memorizzare l'impostazione scelta e tornare ad AH
- Premere UP fino a raggiungere Ad (**A**larm **D**elay time, tempo di ritardo allarme, per AL e AH)
- Premere Set per regolare Ad con UP e DOWN (regolabile tra 0 e 240 minuti); impostazione predefinita = 120 minuti.
- Premere Set per memorizzare l'impostazione scelta e tornare ad Ad
- Tenere premuto Prg/mute per più di 5 sec. per salvare le modifiche e tornare al menu principale.

HOSHIZAKI

Premier Remote Cabinets



Per creare soglie di allarme di temperatura e tempo di ritardo di allarme adatti per un frigorifero o un congelatore, si possono suggerire gli esempi di impostazione di allarme indicati di seguito:

	Valore di impostazione	A1	AL	AH	Ad
Frigorifero	+5 °C	1	+1 °C	+8 °C	120 min.
Congelatore	-18 °C	1	-50 °C	-15 °C	120 min.

Come visualizzare il registro degli allarmi

- Tenere premuti Prg/mute e Set per 5 secondi;
- digitare la password "44"
- Premere Set per accedere a un sottomenu in cui si utilizzano i tasti UP e DOWN per scorrere i vari allarmi, da HS0 a HS9.

- Selezionare un allarme e premere Set per visualizzare il codice, l'ora, i minuti e la durata.
- Da uno qualsiasi dei sottoparametri, premendo Prg/mute il controller tornerà al parametro principale "HSx".

- Premere Prg/mute per 5 secondi per tornare al display standard.

Esempio:

"HI" -> "h17" -> "m23" -> "65"

indica che l'allarme "HI" (allarme temperatura alta) è stato attivato alle ore 17:23 ed è durato 65 minuti.

ALLARMI HACCP

Si gestiscono due tipi di eventi HACCP:

- allarmi di tipo HA, temperatura elevata durante il funzionamento;
- allarmi di tipo HF, temperatura elevata dopo un'interruzione di corrente (blackout).

Quando viene registrato un allarme, il LED HACCP lampeggia, il display mostra il codice di allarme, l'allarme viene salvato e il relè di allarme e il segnale acustico vengono attivati.

Come visualizzare gli allarmi HA e HF

- Premere contemporaneamente Prg/mute e DOWN

- Scorrere l'elenco di allarmi premendo UP e DOWN

- Premere Set per selezionare l'allarme richiesto
- Usare UP o DOWN per visualizzare la descrizione dell'allarme: anno, mese, giorno, ore, minuti e durata in minuti dell'allarme selezionato



- Premere nuovamente Prg/mute per tornare all'elenco precedente.

Inoltre, il menu di allarme HACCP consente le seguenti operazioni:

Come eliminare un allarme HACCP

- Premere Set e DOWN per 5 secondi durante la visualizzazione dell'elenco di allarmi.

Così facendo HACCP lampeggia, il display visualizza il messaggio rES e il monitoraggio degli allarmi HACCP viene reinizializzato

Come eliminare l'intera memoria degli allarmi HACCP

- Premere Set e UP e DOWN per 5 secondi.

Questa procedura visualizza il messaggio rES, elimina l'intera memoria degli allarmi e reinizializza il monitoraggio degli allarmi HACCP.

Per poter utilizzare gli allarmi HACCP, è necessario che l'orologio in tempo reale sia stato regolato dall'azienda installatrice prima di consegnare l'armadio frigo all'utente finale. Queste regolazioni sono protette da un codice di accesso e non possono quindi essere effettuate dall'utente finale.

Luce dell'armadio frigo

Su tutti gli armadi frigo, la luce si trova all'esterno, sopra la porta. Questa luce è azionata dal controller principale, ragion per cui non è possibile modificarne la modalità di funzionamento.

Quando la porta dell'armadio frigo viene aperta, la luce sopra la porta si accende. Quando si chiude la porta, la luce dell'armadio frigo sopra la porta si spegne.

HOSHIZAKI

Premier Remote Cabinets



Errori e allarmi

Display code	Cause of the alarm	Icon flash on display	Alarm relay	Buzzer	Reset	Compressor	Defrost	Evaporator fans	Continuous cycle	Signalled on tLAN	Network solenoid valve
rE	Control probe fault		ON	ON	automatic	duty setting(c4)	unchanged	unchanged	unchanged	√	-
E1	Probe S1 fault		OFF	OFF	automatic	duty setting(c4)	unchanged	unchanged	unchanged	√	-
E2	Probe S2 fault		OFF	OFF	automatic	unchanged	unchanged	unchanged	unchanged	√	-
E3	Probe S3 fault		OFF	OFF	automatic	unchanged	unchanged	unchanged	unchanged	√	-
E4	Probe S4 fault		OFF	OFF	automatic	unchanged	unchanged	unchanged	unchanged	√	-
E5	Probe S5 fault		OFF	OFF	automatic	unchanged	unchanged	unchanged	unchanged	√	-
E6	Probe S6 fault		OFF	OFF	automatic	unchanged	unchanged	unchanged	unchanged	√	-
E7	Probe S7 fault		OFF	OFF	automatic	unchanged	unchanged	unchanged	unchanged	√	-
E8	Serial probe S8 not updated		OFF	OFF	automatic	duty setting(c4)	unchanged	unchanged	unchanged	√	-
E9	Serial probe S9 not updated		OFF	OFF	automatic	duty setting(c4)	unchanged	unchanged	unchanged	√	-
E10	Serial probe S10 not updated		OFF	OFF	automatic	duty setting(c4)	unchanged	unchanged	unchanged	√	-
E11	Serial probe S11 not updated		OFF	OFF	automatic	duty setting(c4)	unchanged	unchanged	unchanged	√	-
LO	Low temperature alarm		ON	ON	automatic	unchanged	unchanged	unchanged	unchanged	√	-
HI	High temperature alarm		ON	ON	automatic	unchanged	unchanged	unchanged	unchanged	√	-
LO2	Low temperature alarm		ON	ON	automatic	unchanged	unchanged	unchanged	unchanged	√	-
HI2	High temperature alarm		ON	ON	automatic	unchanged	unchanged	unchanged	unchanged	√	-
IA	Immediate alarm from external contact		ON	ON	automatic	duty setting(A6)	unchanged	unchanged	unchanged	√	-
dA	Delayed alarm from external contact		ON	ON	automatic	duty setting(A6) if A7≠0	unchanged	unchanged	unchanged	√	-
dor	Door open for too long alarm		ON	ON	automatic	unchanged	unchanged	unchanged	unchanged	√	-
Etc	Real time clock fault		OFF	OFF	automatic	unchanged	unchanged	unchanged	unchanged	√	-
LSH	Low superheat alarm		OFF	OFF	automatic	OFF	unchanged	unchanged	unchanged	√	√
LSA	Low suction temperature alarm		OFF	OFF	automatic / manual	OFF (paragraph 6.10)	unchanged	unchanged	unchanged	√	√
MOP	Maximum evaporation pressure alarm		OFF	OFF	automatic	OFF	unchanged	unchanged	unchanged	√	√
LOP	Low evaporation temperature alarm		OFF	OFF	automatic	unchanged	unchanged	unchanged	unchanged	√	√
bLo	Valve blocked alarm		OFF	OFF	manual/ disabled with P14=0	unchanged	unchanged	unchanged	unchanged	√	-
Edc	Communication error with stepper driver		ON	ON	automatic	unchanged	unchanged	unchanged	unchanged	√	-
EFS	Stepper motor broken/not connected		ON	ON	automatic	unchanged	unchanged	unchanged	unchanged	√	-
EE	Flash unit parameter error		OFF	OFF	automatic	OFF	not performed	OFF	not performed	√	-
EF	EEPROM operating parameter error		OFF	OFF	automatic	OFF	not performed	OFF	not performed	√	-
HA	Type HA HACCP alarm	HACCP	OFF	OFF	manual	unchanged	unchanged	unchanged	unchanged	√	-
HF	Type HF HACCP alarm	HACCP	OFF	OFF	manual	unchanged	unchanged	unchanged	unchanged	√	-
MA	Communication error with Master (only on Slave)		ON	ON	automatic	unchanged	unchanged	unchanged	unchanged	-	-
u1...u5	Communication error with Slave (only on Master)		ON	ON	automatic	unchanged	unchanged	unchanged	unchanged	-	-
n1...n5	Alarm on unit 1 to 5 in the network		ON	ON	automatic	unchanged	unchanged	unchanged	unchanged	-	-
up1...up5	Upload procedure with errors on unit 1 to 5		OFF	OFF	-	unchanged	unchanged	unchanged	unchanged	-	-
GPE	Error in custom gas parameters		ON	ON	automatic	OFF	not performed	OFF	not performed	√	-



Per ulteriori informazioni, consultare il manuale del controller CO2 selezionato.
(Carel MPX PRO)

Uso del prodotto (Nessun controller - Modello NC)



Consultare il manuale fornito con il controller installato.

Risoluzione dei problemi

Rumore:

- In caso di rumore anomalo, richiedere assistenza.
- I rumori di funzionamento provenienti dalla ventola interna sono normali.
- Se le parti in lamiera, i pannelli anteriori o i pannelli davanti allo scomparto fanno rumore, è probabile che siano aperti. Chiudere i pannelli.

Brina all'interno dello scomparto:

- Umidità ambiente troppo elevata.
- Apertura troppo frequente della porta.
- Porta lasciata aperta troppo a lungo.
- Guarnizione della porta danneggiata. Controllarne accuratamente l'integrità.

Scarse prestazioni di raffreddamento:

- Temperatura ambiente troppo alta.
- Apertura troppo frequente e per troppo tempo della porta.
- Porta lasciata aperta.
- Guarnizione della porta danneggiata.
- Impostazione della temperatura troppo alta.
- Troppi alimenti nel prodotto – ingresso/uscita dell'aria ostruiti.
- Alimenti caldi o bollenti all'interno del prodotto.
- Sbrinamento in corso. La temperatura dell'armadio frigo può aumentare temporaneamente durante il ciclo di sbrinamento, ma senza ripercussioni sugli alimenti presenti al suo interno. LED di sbrinamento coperto.

Alcuni alimenti sono congelati:

- Troppi alimenti nel prodotto – ingresso/uscita dell'aria ostruiti.
- Valore di impostazione della temperatura troppo basso.
- Ventola dell'evaporatore probabilmente difettosa.

Condensa intorno alla porta:

- Umidità ambiente troppo elevata.
- Porta non correttamente chiusa.
- Guarnizione della porta danneggiata.
- Parametro relativo al riscaldatore del telaio della porta non correttamente regolato.

Consumo energetico troppo elevato:

- Temperatura ambiente troppo alta.
- Apertura troppo frequente e per troppo tempo della porta.
- Porta lasciata aperta.
- Guarnizione della porta danneggiata.
- Valore di impostazione della temperatura troppo basso.
- Troppi alimenti all'interno del prodotto – ingresso/uscita dell'aria ostruiti.
- Introduzione di alimenti caldi o bollenti nel prodotto.
- Prodotto esposto alla luce diretta del sole o ubicato vicino a superfici che emettono calore.
- Impostazioni predefinite modificate.

Acqua di sbrinamento

Durante lo sbrinamento, il prodotto produce acqua che viene condotta nel sistema di rievaporazione per aspirazione mediante un componente in plastica posto nella parte superiore dell'armadio frigo (per gli armadi frigo Premier)

L'acqua viene fatta rievaporare con un elemento riscaldante elettrico e un motore a ventola. In rari casi il modello di utilizzo dell'armadio frigo crea più acqua di quanta il prodotto sia in grado di rievaporare, ragion per cui l'acqua può fuoriuscire. In questo caso è possibile cambiare l'elemento riscaldante elettrico perché funzioni al 100%; in alternativa, scollegarlo e collegare invece il tubo dell'acqua sul retro a uno scarico. Tali modifiche devono essere effettuate da un tecnico qualificato.

Meccanismo di chiusura della porta

La porta è dotata di un sistema di chiusura automatica. Se la porta viene aperta a meno di 90°, si chiuderà da sola. Se la porta viene aperta a più di 90°, rimarrà aperta.

La porta può essere aperta usando il pedale. Ciò consente di avere entrambe le mani libere quando si posizionano gli alimenti nell'armadio frigo.

Interruzione di corrente

In caso di interruzione di corrente, il comando ricorda l'impostazione della temperatura e riavvia il prodotto quando l'alimentazione elettrica viene ripristinata.

Pulizia



Una pulizia insufficiente impedirà al prodotto di funzionare alle prestazioni ottimali, fino a guastarlo.



Prima della pulizia, occorre sempre scollegare il prodotto.

Non sciacquare il prodotto con acqua e non usare getti d'acqua o tubi vapore, in quanto si rischia di causare cortocircuiti nel sistema elettrico.



Non si devono utilizzare prodotti detergenti contenenti cloro o composti di cloro nonché altri mezzi corrosivi, in quanto rischiano di corrodere i pannelli inossidabili dell'armadio frigo e dell'evaporatore.



Il prodotto deve essere tenuto pulito da polvere e sporcizia. A tale scopo, è meglio utilizzare un aspirapolvere e una spazzola.



Per la manutenzione esterna, utilizzare lucidante per acciaio inossidabile.



Il prodotto deve essere pulito internamente con una soluzione di sapone neutro a intervalli opportuni e controllato accuratamente prima di essere rimesso in funzione.

Guarnizioni della porta

Questo capitolo tratta dell'importanza di una guarnizione ben funzionante.

Le guarnizioni sono una parte importante di un frigorifero/congelatore. Guarnizioni con funzionalità ridotta riducono la tenuta dell'armadio frigo. La ridotta tenuta rischia di causare l'aumento dell'umidità, la formazione di brina all'interno del prodotto, la formazione di brina nell'evaporatore (con conseguente riduzione della capacità di refrigerazione) e, nel peggiore dei casi, ridurre il ciclo di vita dell'armadio frigo.



Pertanto, è importante essere a conoscenza delle condizioni della guarnizione. Si raccomanda un'ispezione regolare.

La guarnizione deve essere pulita regolarmente con una soluzione di sapone neutro. Se una guarnizione deve essere sostituita, contattare il fornitore.

Conservazione a lungo termine

Se il prodotto non è in funzione e deve essere preparato per la conservazione a lungo termine, pulire accuratamente lo scomparto interno, la porta e la sua guarnizione con un panno umido insaponato e caldo. Eventuali residui di cibo potrebbero creare muffa.

Assistenza

Se la refrigerazione si guasta, verificare innanzitutto se l'unità è stata scollegata o spenta involontariamente dalla presa o se si è bruciato un fusibile.

Se non è possibile individuare la causa del guasto della refrigerazione, contattare l'installatore dell'unità.

Quando si contatta HOSHIZAKI o l'installatore, indicare il nome e il numero di serie all'interno dell'armadio frigo. Queste informazioni sono riportate sulla targhetta.

HOSHIZAKI

Premier Remote Cabinets



Dati tecnici

Posizione dell'etichetta:

PRODUCT DESCRIPTION LABEL		
1 Product Number		
2 Product Description		
3 Model		
4 Refrigerant (GWP)		
5 CO2 Equivalent		
6 IP Protection		
7 Climate Class		
8 Production Date		
9 Total power / Current / Lamp power		
10 Voltage - Frequency		
11 Heating Element		
12 System Pressure		
13 Blowing Agent		
14 Serial Number		

PRODUCT NUMBER	1
PRODUCT DESCRIPTION	2
MODEL	3
REFRIGERANT	4
CO2 EQUIVALENT	5
IP PROTECTION	6
CLIMATE CLASS	7
PRODUCTION DATE	8
TOTAL POWER / CURRENT / LAMP POWER	9
VOLTAGE - FREQUENCY	10
HEATING ELEMENT	11
SYSTEM PRESSURE	12
BLOWING AGENT	13

S/N: 14

HOSHIZAKI EUROPE B.V. Burgemeester Stramanweg 101 1101 AA Amsterdam, The Netherlands

Trade mark			HOSHIZAKI			
Model name			PREMIER U 70	PREMIER U 140	PREMIER U 80	PREMIER U 60
Usò previsto			Storage	Storage	Storage	Storage
Temperatura di esercizio per la			X	X	X	X
Temperatura di esercizio per il			X	X	X	X
Armadio frigo multiuso						
Armadio frigo verticale			X	X	X	X
Banco refrigerato						
Parameter	Symbol	Unit				
Volume lordo	VnT	L	700	1400	700	480
Classe climatica			CC5	CC5	CC5	CC5
Tensione/frequenza di	V / Hz		230 - 50	230 - 50	230 - 50	230 - 50
Refrigerante (Armadio frigo)			CO2	CO2	CO2	CO2
Refrigerante (Armadio frigo modello RU-1)			HFC / HFO Refrigerant*	HFC / HFO Refrigerant*	HFC / HFO Refrigerant*	HFC / HFO Refrigerant*
Informazioni di contatto:			HOSHIZAKI EUROPE B.V. Address: Burgemeester Stramanweg 101 1101 AA Amsterdam, The Netherlands Tel: +31 (0)20 691 84 99 - http://hoshizaki.europe.com/			

* Refrigeranti compatibili con l'ugello (R449A, R448A, R45A, ecc. Controllare la scheda tecnica d'uso dell'ugello)

HOSHIZAKI

Premier Remote Cabinets



Trade mark			HOSHIZAKI		
Model name			BAKER U 950	BAKER GA 950	PREMIER SF 950
Uso previsto			Storage	Cooling /Freezing / Storage / Proving	Cooling / Shock Freezing
Temperatura di esercizio per la			X	X	X
Temperatura di esercizio per il			X	X	X
Armadio frigo multiuso				X	X
Armadio frigo verticale			X	X	X
Banco refrigerato					
Parameter	Symbol	Unit			
Volume lordo	VnT	L	1000	950	950
Classe climatica			CC5	CC5	CC5
Tensione/frequenza di	V / Hz		230 - 50	230 – 50	230 – 50
Refrigerante (Armadio frigo modello RU-1)			HFC / HFO Refrigerant*	HFC / HFO Refrigerant*	HFC / HFO Refrigerant*
Informazioni di contatto:	HOSHIZAKI EUROPE B.V. Address: Burgemeester Stramanweg 101 1101 AA Amsterdam, The Netherlands Tel: +31 (0)20 691 84 99 - http://hoshizaki.europe.com/				

* Refrigeranti compatibili con l'ugello (R449A, R448A, R45A, ecc. Controllare la scheda tecnica d'uso dell'ugello)

HOSHIZAKI

Premier Remote Cabinets



Dimensioni

PREMIER U 70

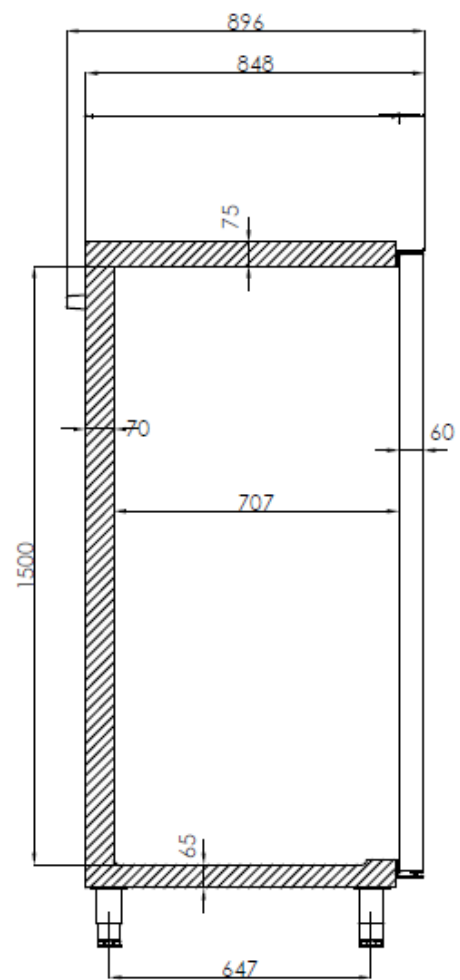
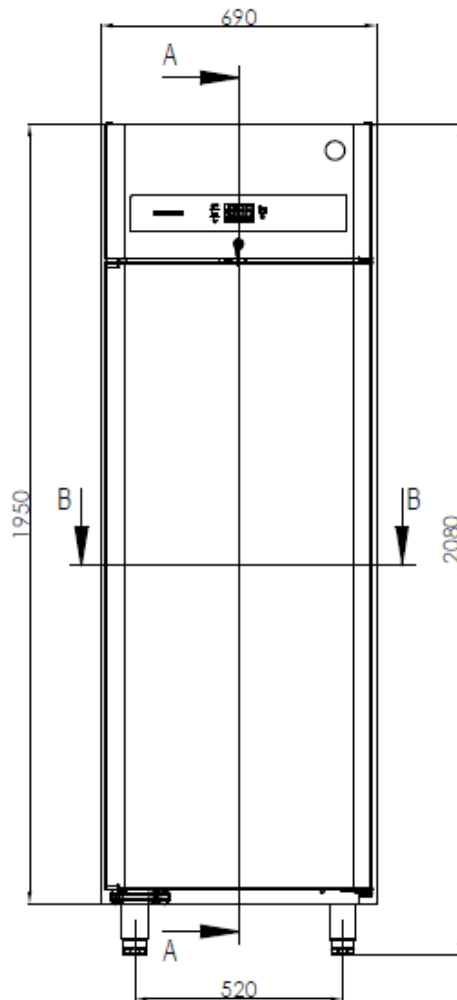

A-A

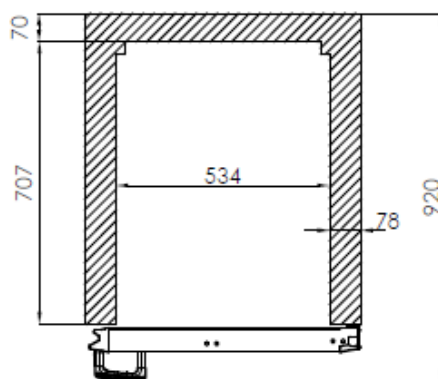

B-B

HOSHIZAKI

Premier Remote Cabinets



PREMIER U 60

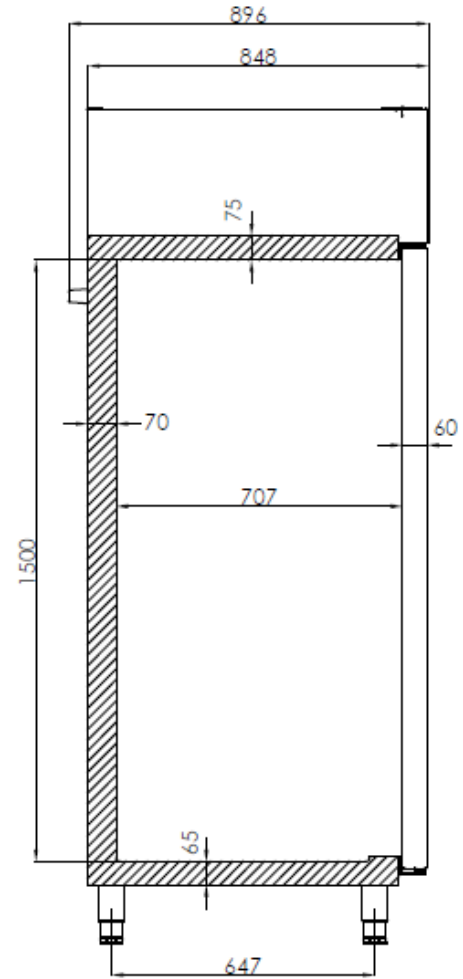
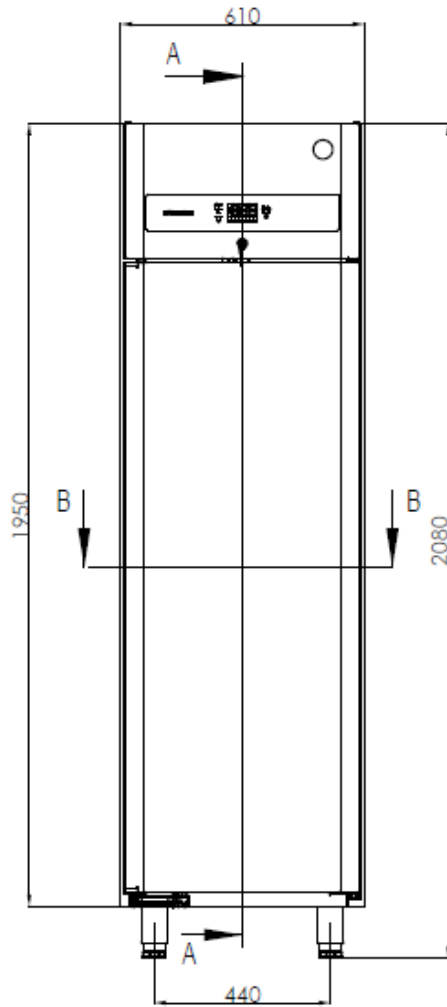

A-A

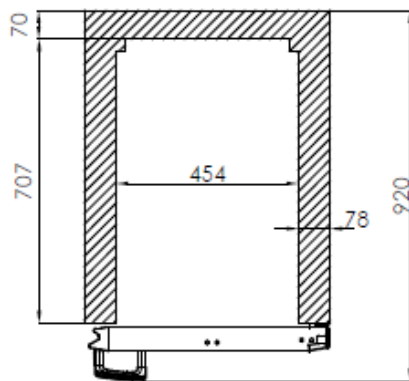

B-B

HOSHIZAKI

Premier Remote Cabinets



PREMIER U 80

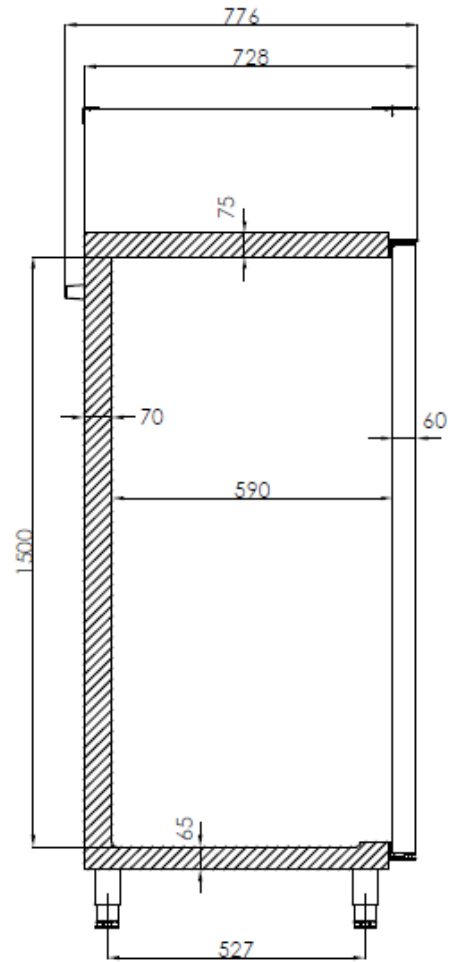
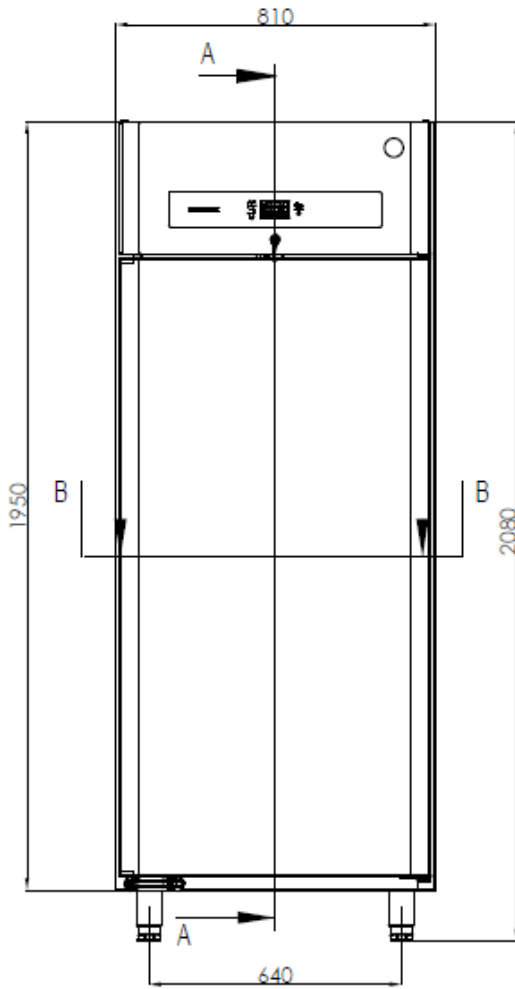

A-A

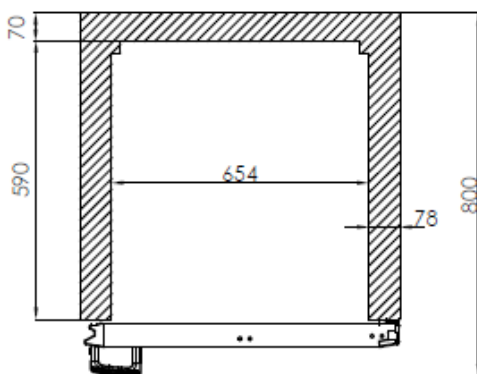

B-B

HOSHIZAKI

Premier Remote Cabinets



PREMIER U 140

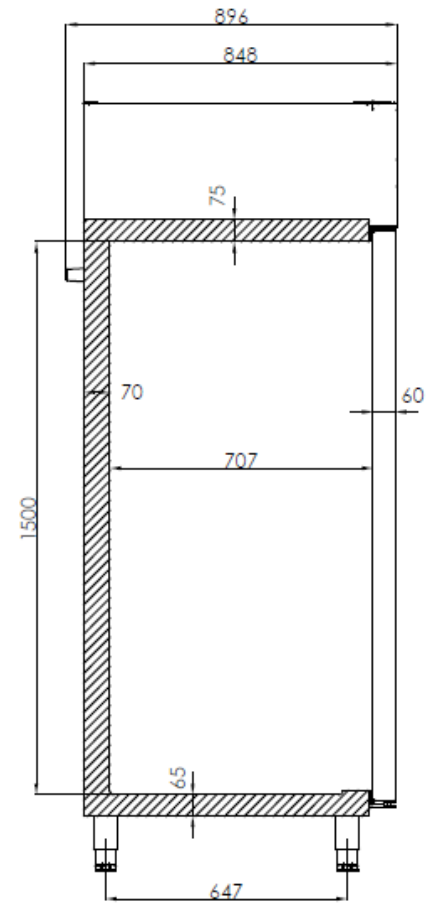
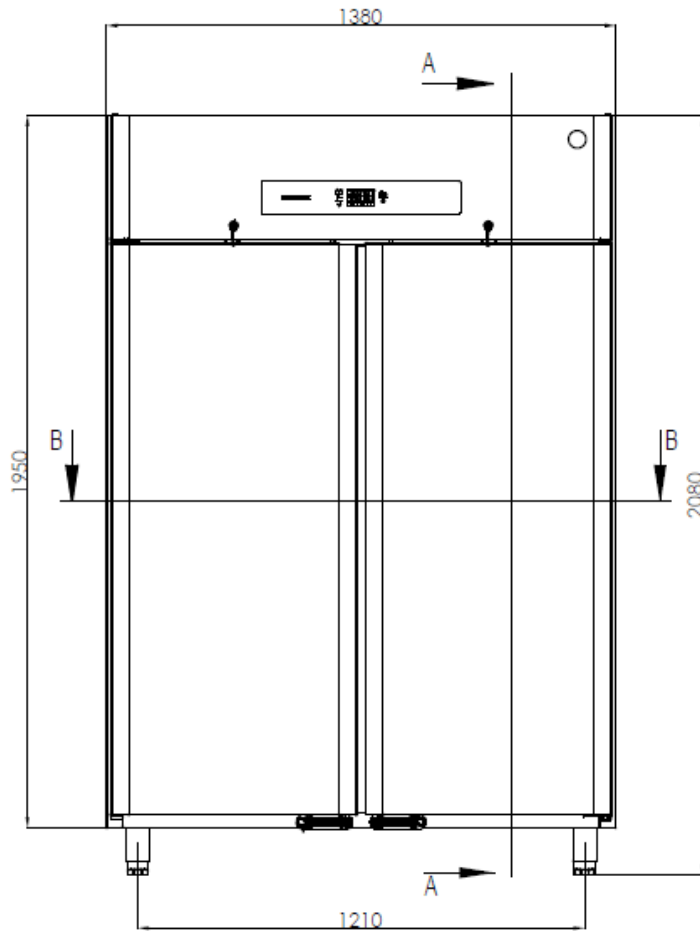

A-A

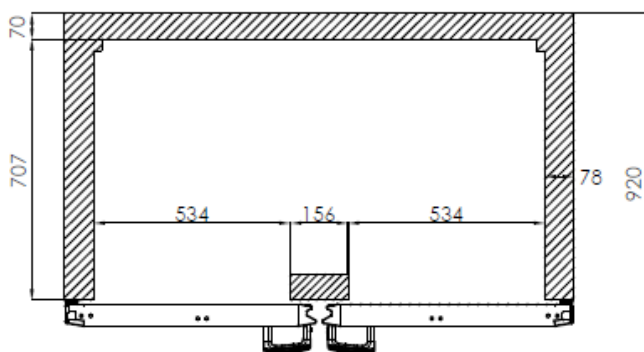

B-B

HOSHIZAKI

Premier Remote Cabinets



BAKER U 950

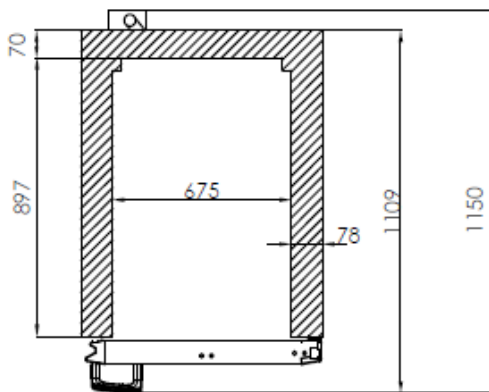
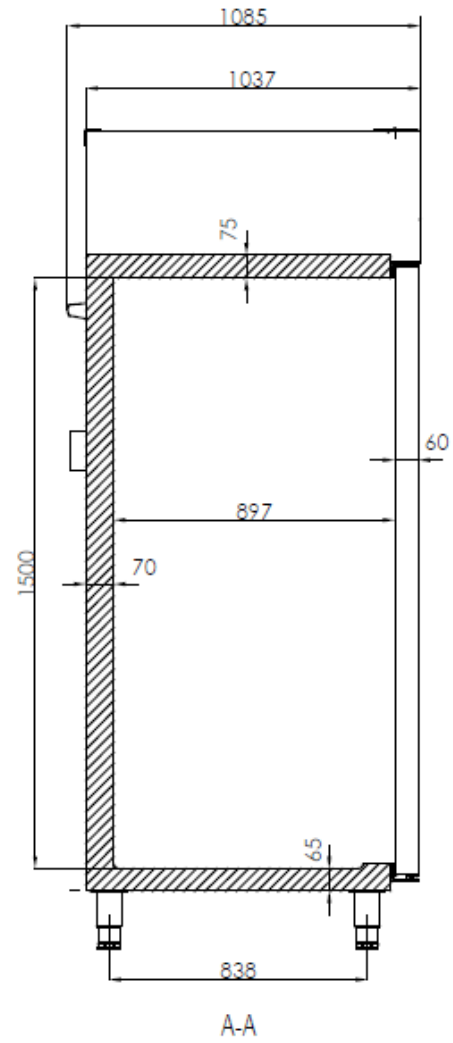
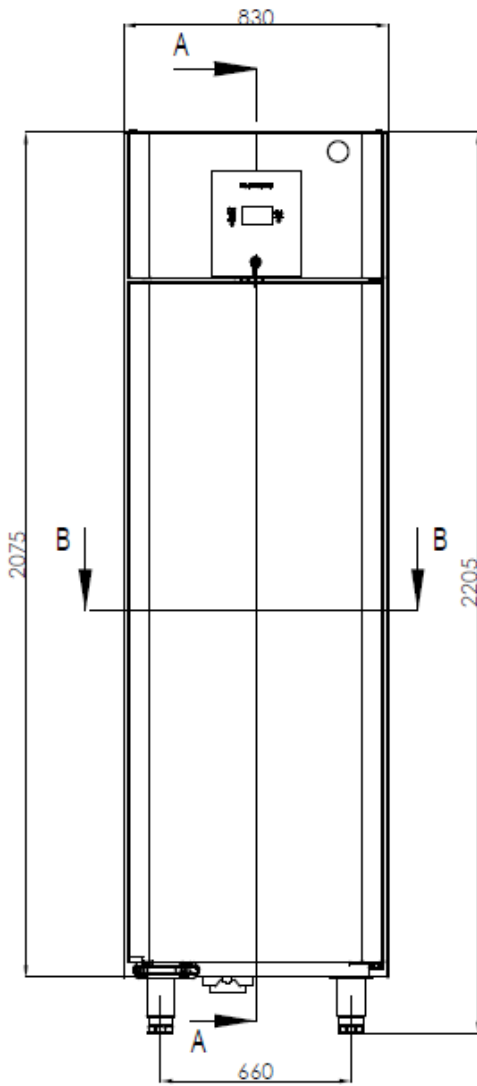

HOSHIZAKI

Premier Remote Cabinets



BAKER GA 950 (RU1)

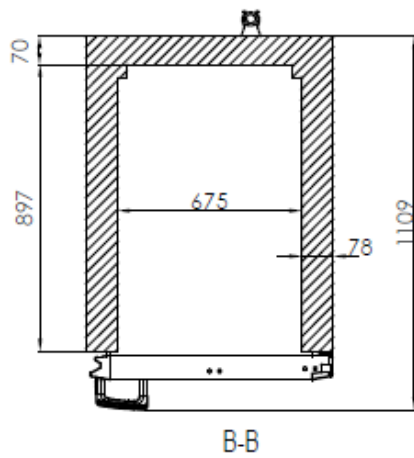
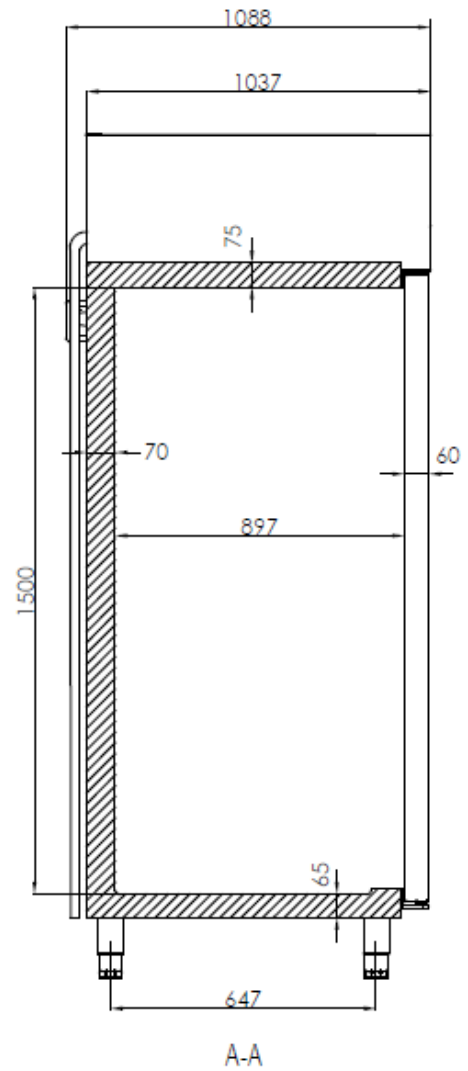
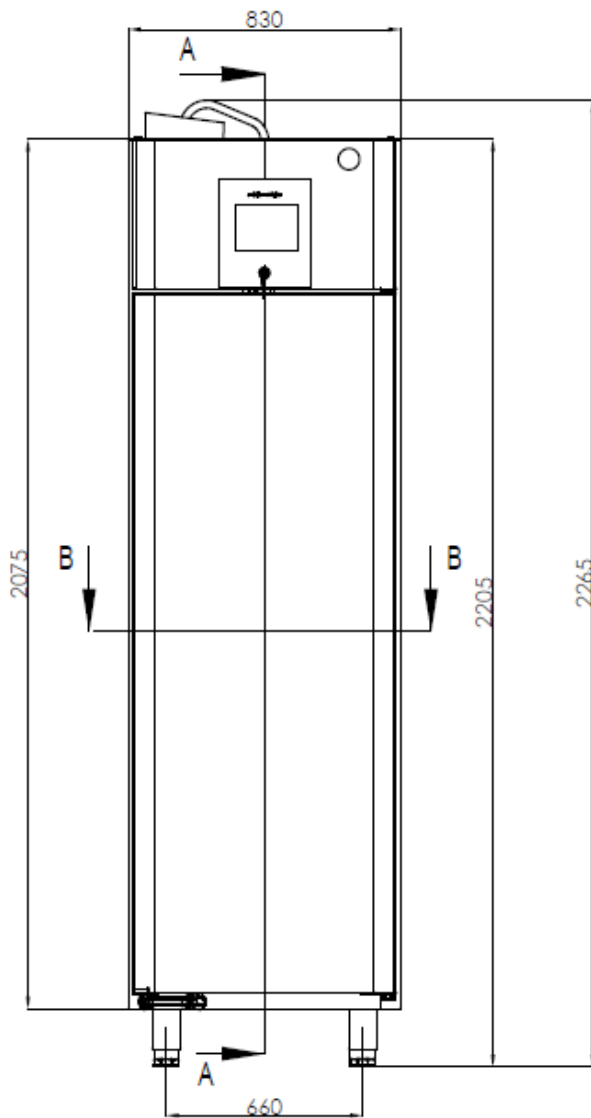

HOSHIZAKI

Premier Remote Cabinets



BAKER SF 950 (RU1)

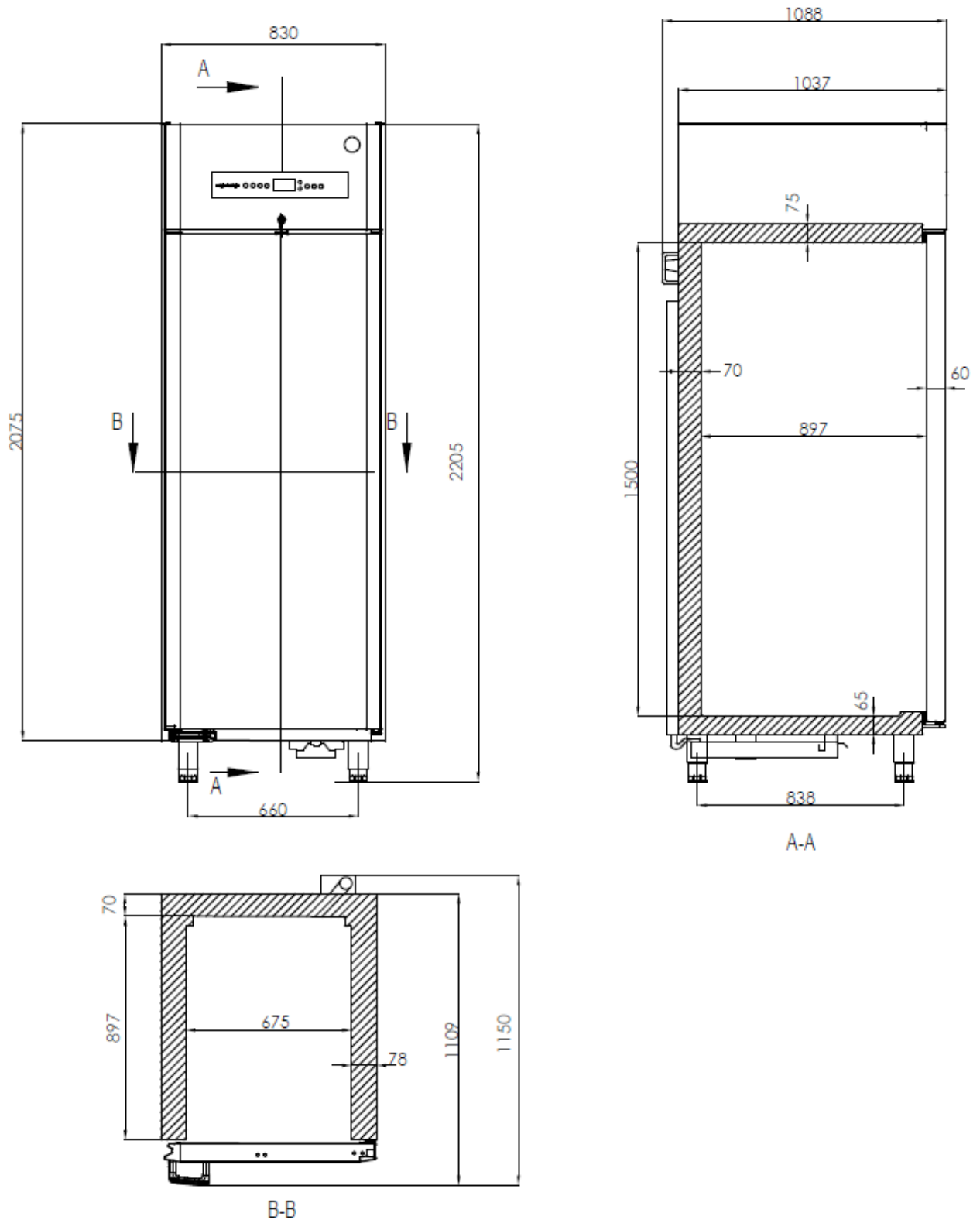

Smaltimento

Il testo che segue riguarda unicamente il Regno Unito.

Lo smaltimento di un vecchio armadio frigo è disponibile solo in caso di consegna contemporanea di uno nuovo. Gli armadi frigo devono essere completamente sbrinati e svuotati prima della raccolta.

Hoshizaki riconosce che i nostri prodotti per il mercato della ristorazione sono considerati RAEE quando diventano obsoleti. Per garantire che le responsabilità di Hoshizaki siano gestite correttamente e nel rispetto dell'ambiente, abbiamo sottoscritto il più grande programma di conformità business-to-business del Regno Unito: B2B Compliance <http://www.b2bcompliance.org.uk>

B2B Compliance si occuperà per nostro conto di tutte le aree di nostra responsabilità nella raccolta e nello smaltimento delle apparecchiature che rientrano nella normativa RAEE del Regno Unito. È possibile contattare B2B Compliance al numero di telefono +44 (0)1691 676124.





Schemi elettrici

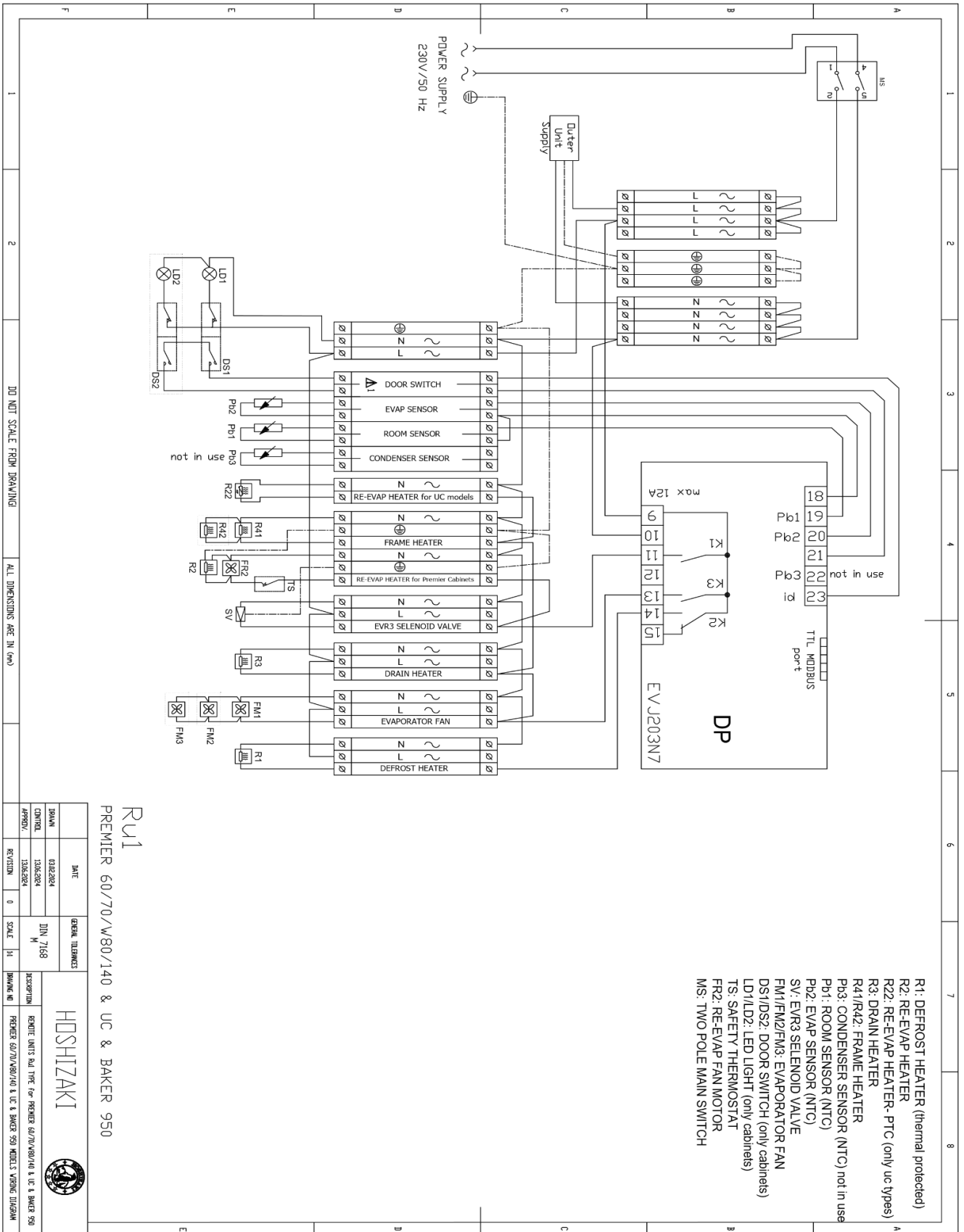

RU1
PREMIER 60/70/W80/140 & UC & BAKER 950

DATE	GENERAL TOLERANCES	HOSHIZAKI
DRAWN	DIN 7168	
CONTROL	M	
APPROV.	13582824	DESCRIPTION
REVISION	0	SCALE
SCALE	1:1	DRAWING NO.
PREMIER 60/70/W80/140 & UC & BAKER 950 MODEL'S VARIANTE DUEMAN		

HOSHIZAKI Premier Remote Cabinets

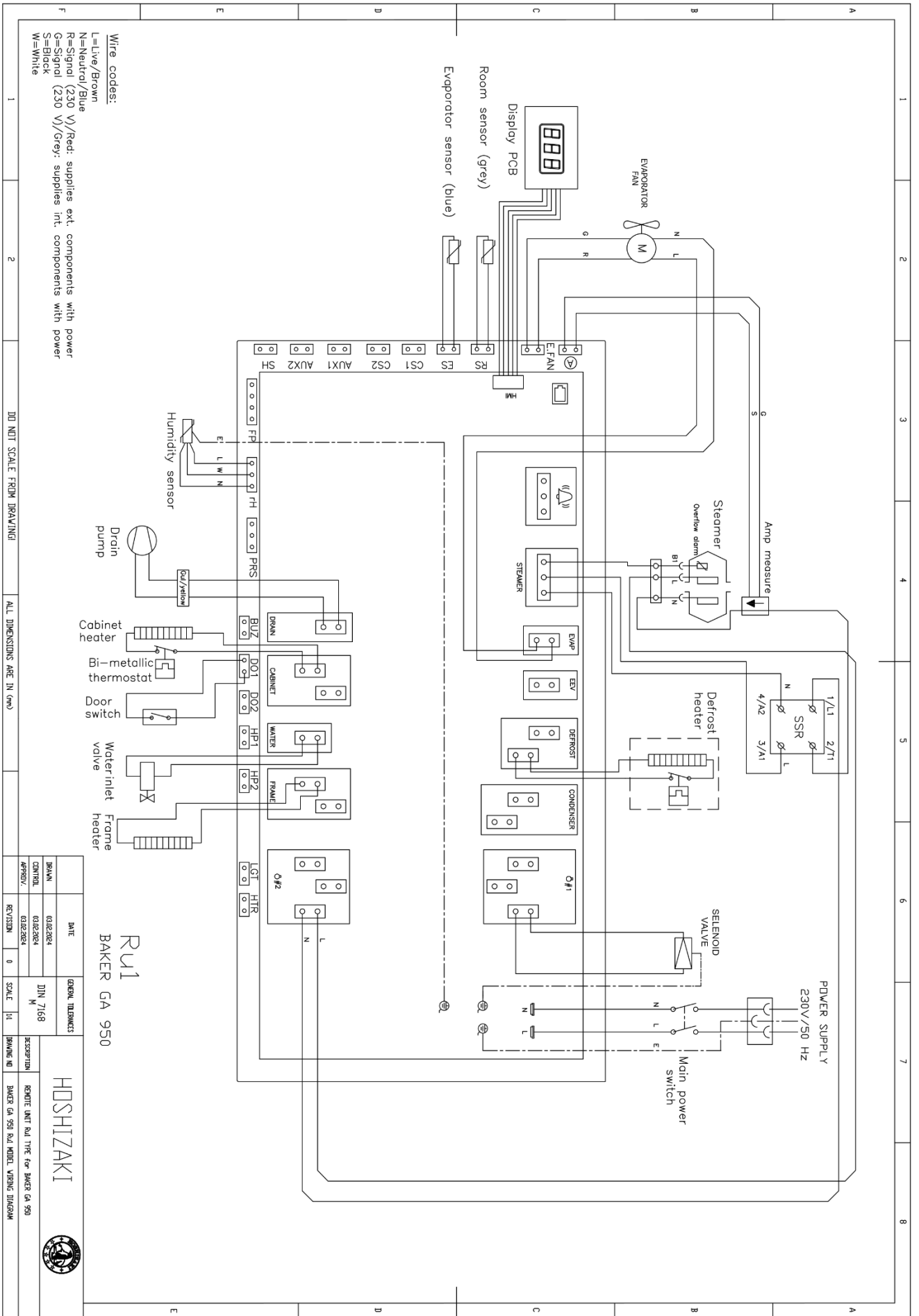

HOSHIZAKI

Premier Remote Cabinets

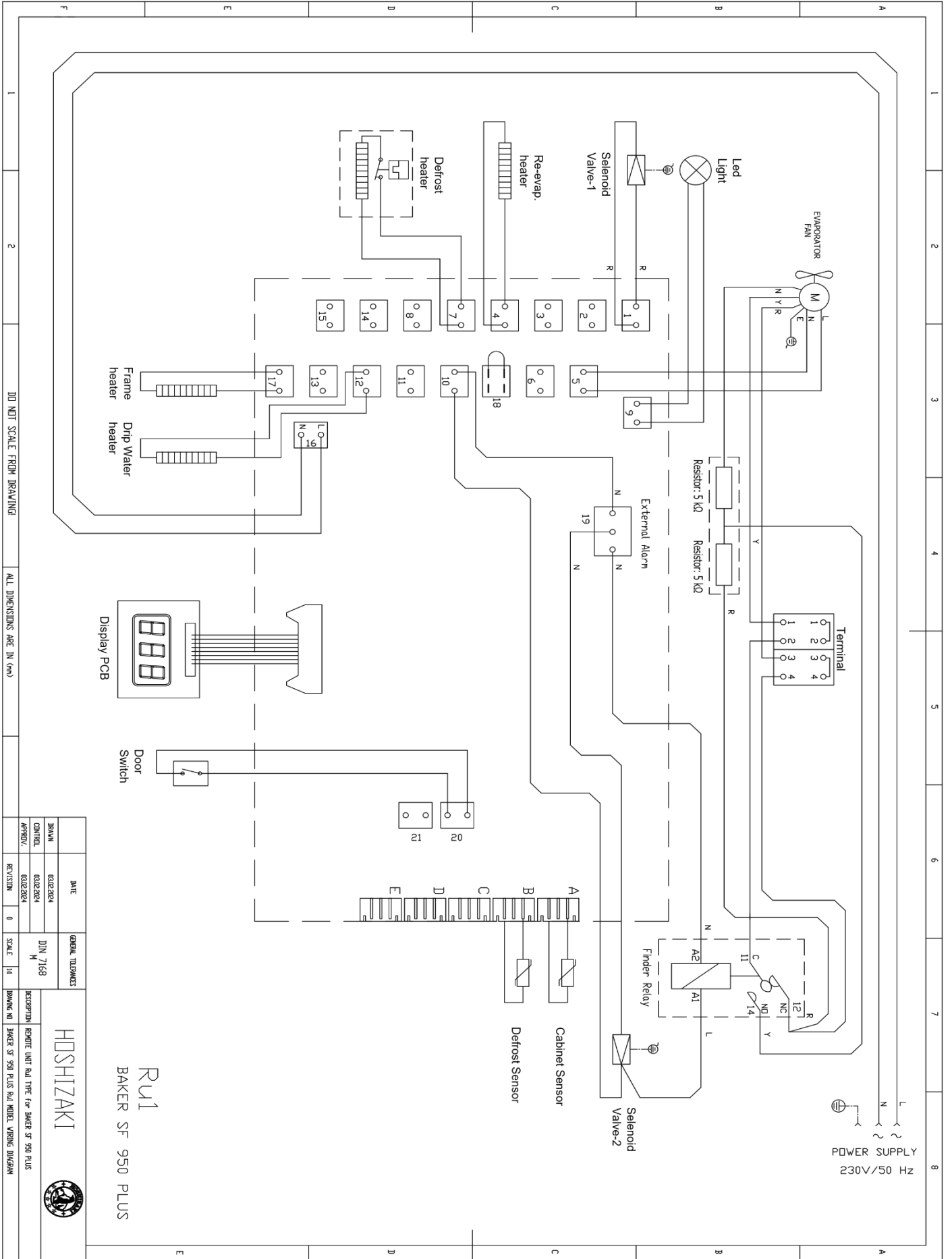

DO NOT SCALE FROM DRAWING

ALL DIMENSIONS ARE IN (mm)

GENERAL DIMENSIONS		DATE	
DRAWN	03022824	DATE	03022824
CONTROL	03022824	REVISION	0
APPROV.	03022824	SCALE	1:1

HOSHIZAKI



RU1
BAKER SF 950 PLUS

RECEPTION REPORT UNIT RAU TYPE FOR BAKER SF 950 PLUS
DRAWING NO BAKER SF 950 PLUS RAU MODEL VARIOUS DIMENSIONS

HOSHIZAKI Premier Remote Cabinets

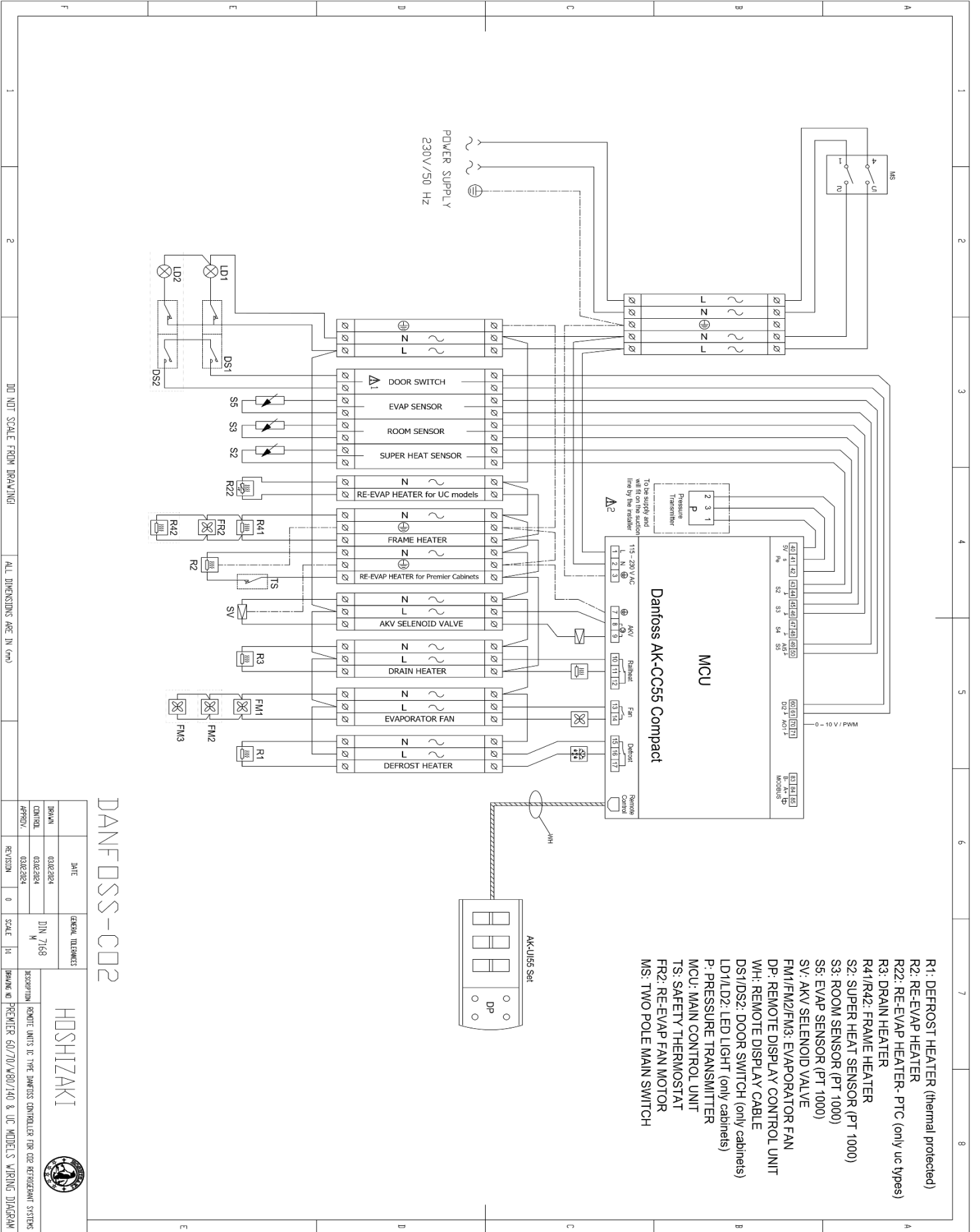

DANFOSS-CC2

DATE	03.02.2024	GENERAL TOLERANCES	DIN 7168
DRAWN	03.02.2024		
CONTROL	03.02.2024		
APPROV.	03.02.2024		
REVISION	0	SCALE	1:1

DESCRIPTION: REMOTE UNITS TO THE DANFOSS CONTROLLER FOR CO2 REFRIGERANT SYSTEMS
 DRAWING NO: PREMIER 60/70/80/140 & UC MODELS WIRING DIAGRAM

HOSHIZAKI



HOSHIZAKI Premier Remote Cabinets

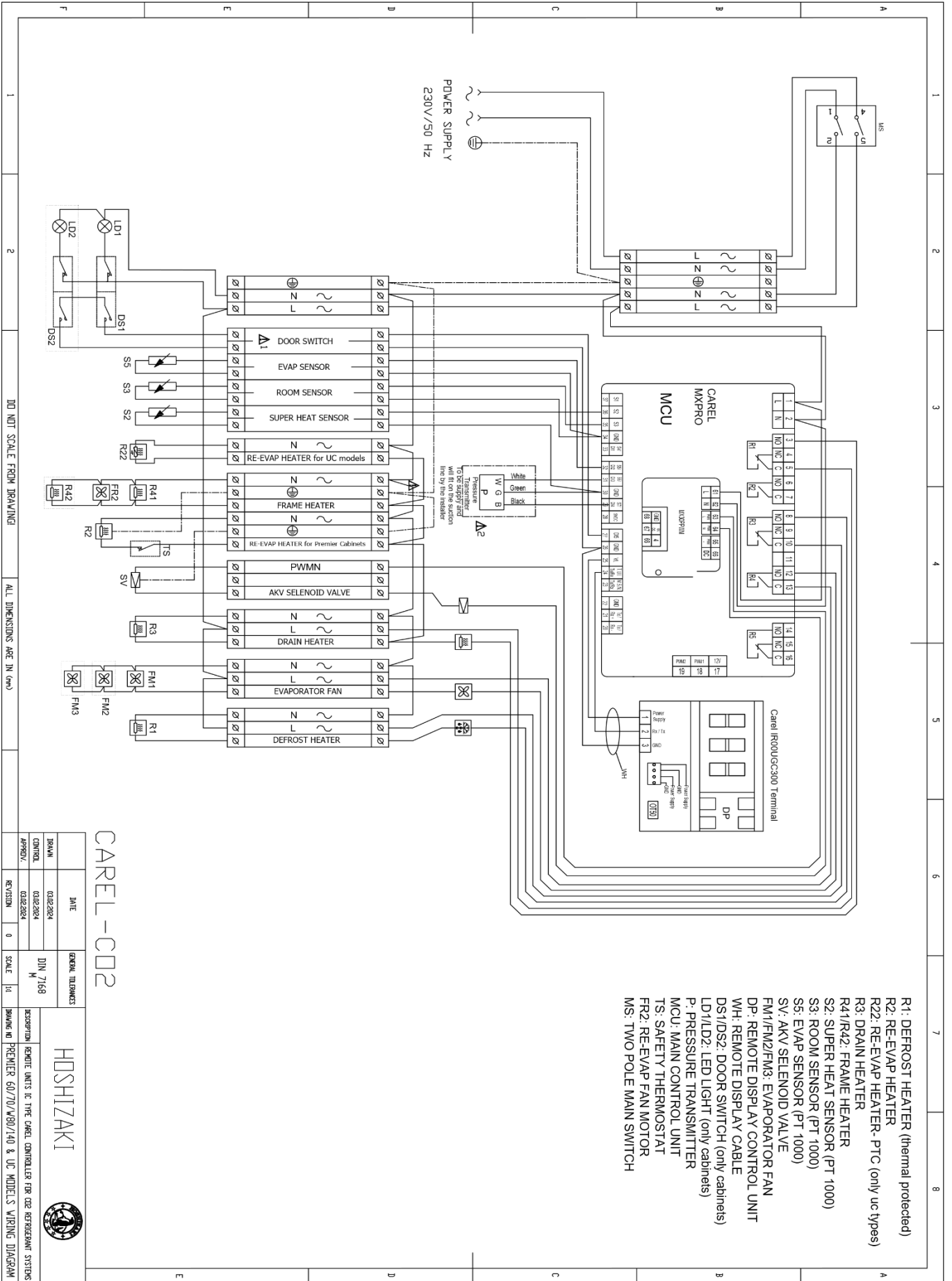

CAREL-C02

DATE		GENERAL TOLERANCES	
DRAWN	02/23/2014	DIN	7168
CHECKED	02/23/2014	M	
APPROVED	02/23/2014	SCALE	1:1
REVISION	0	DRAWING NO: PREMIER 60/70/W/90/140 & UC MODELS WIRING DIAGRAM	



HOSHIZAKI Premier Remote Cabinets

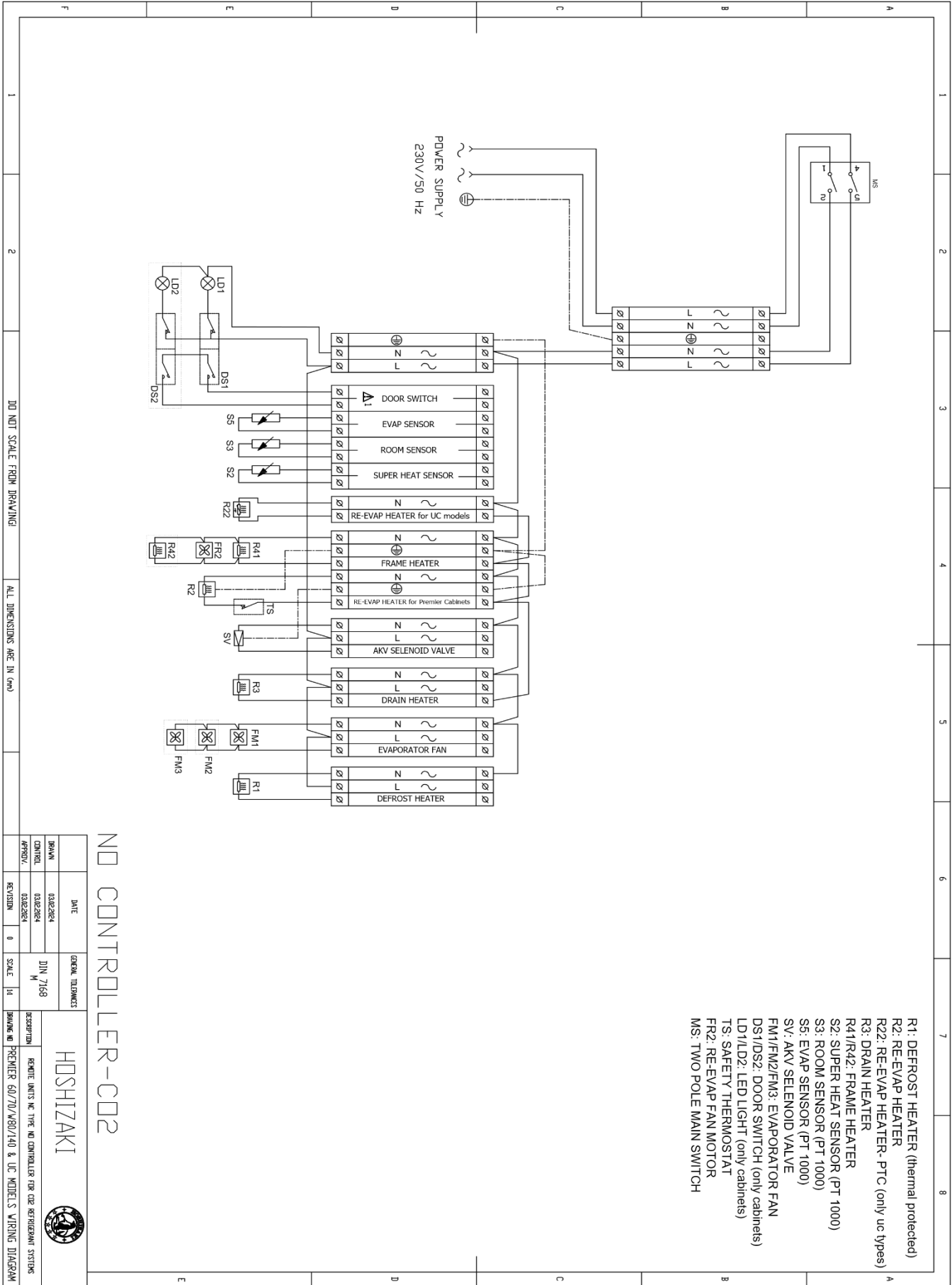

NO CONTROLLER-CD2

GENERAL INFORMATION	
DATE	02.02.2014
DRAWN	02.02.2014
CONTROL	02.02.2014
APPROV.	02.02.2014
REVISION	0
SCALE	1:1

HOSHIZAKI

REMOTE UNITS NC TYPE NO CONTROLLER FOR CDR REFRIGERANT SYSTEMS

PREMIER 60/70/80/140 & UC MODELS WIRING DIAGRAM



Schemi di raffreddamento

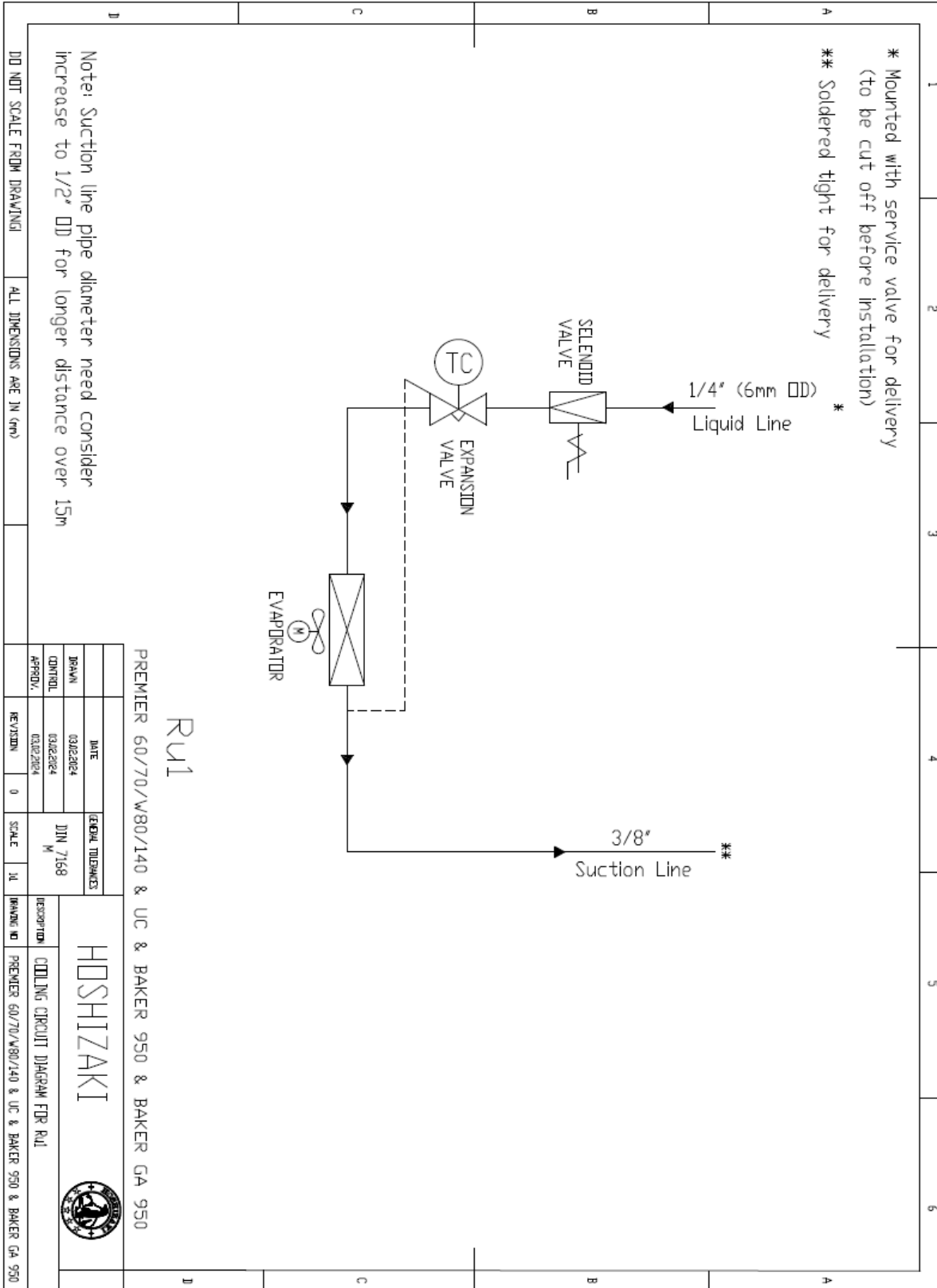

HOSHIZAKI

Premier Remote Cabinets

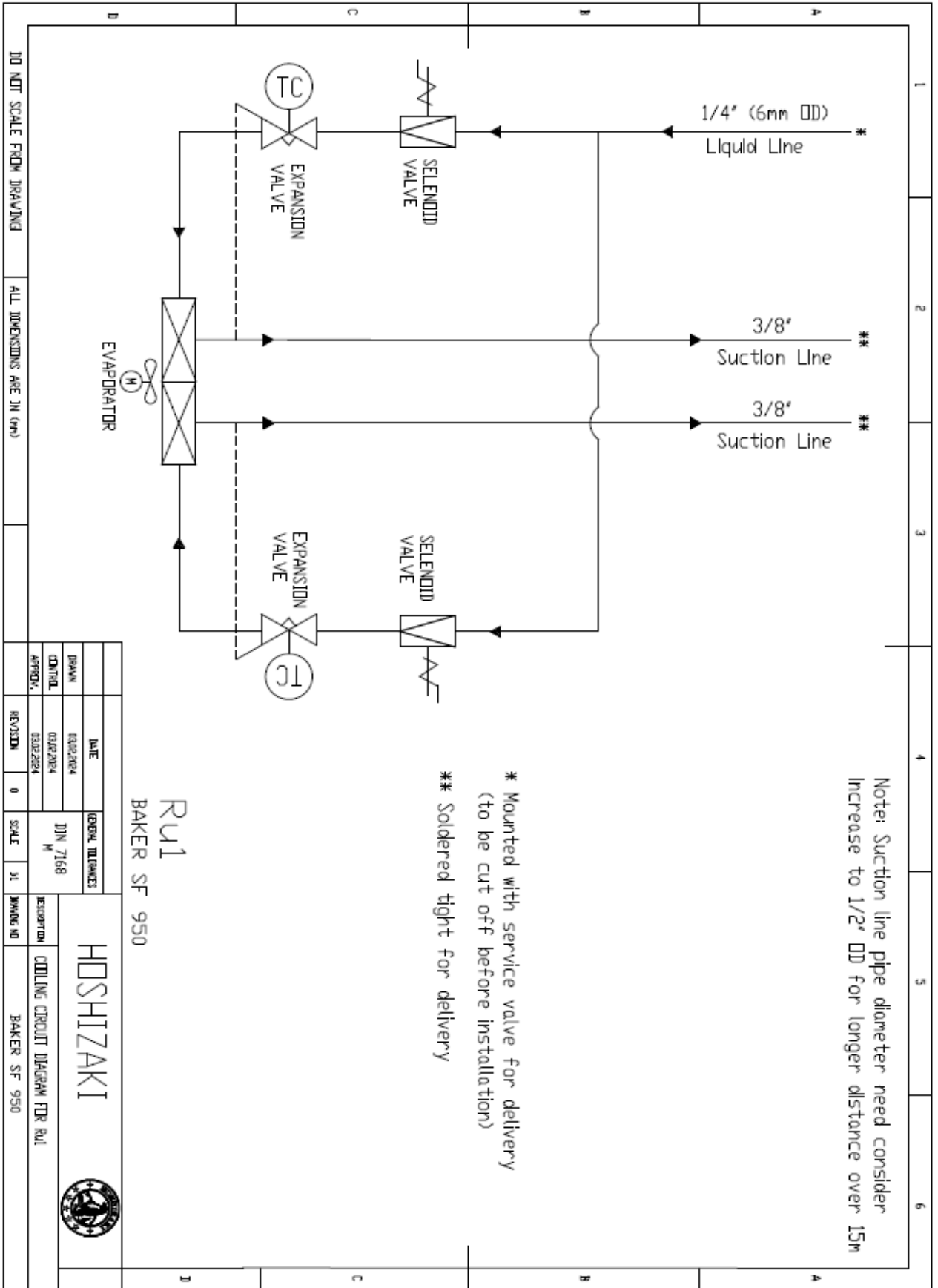

HOSHIZAKI

Premier Remote Cabinets

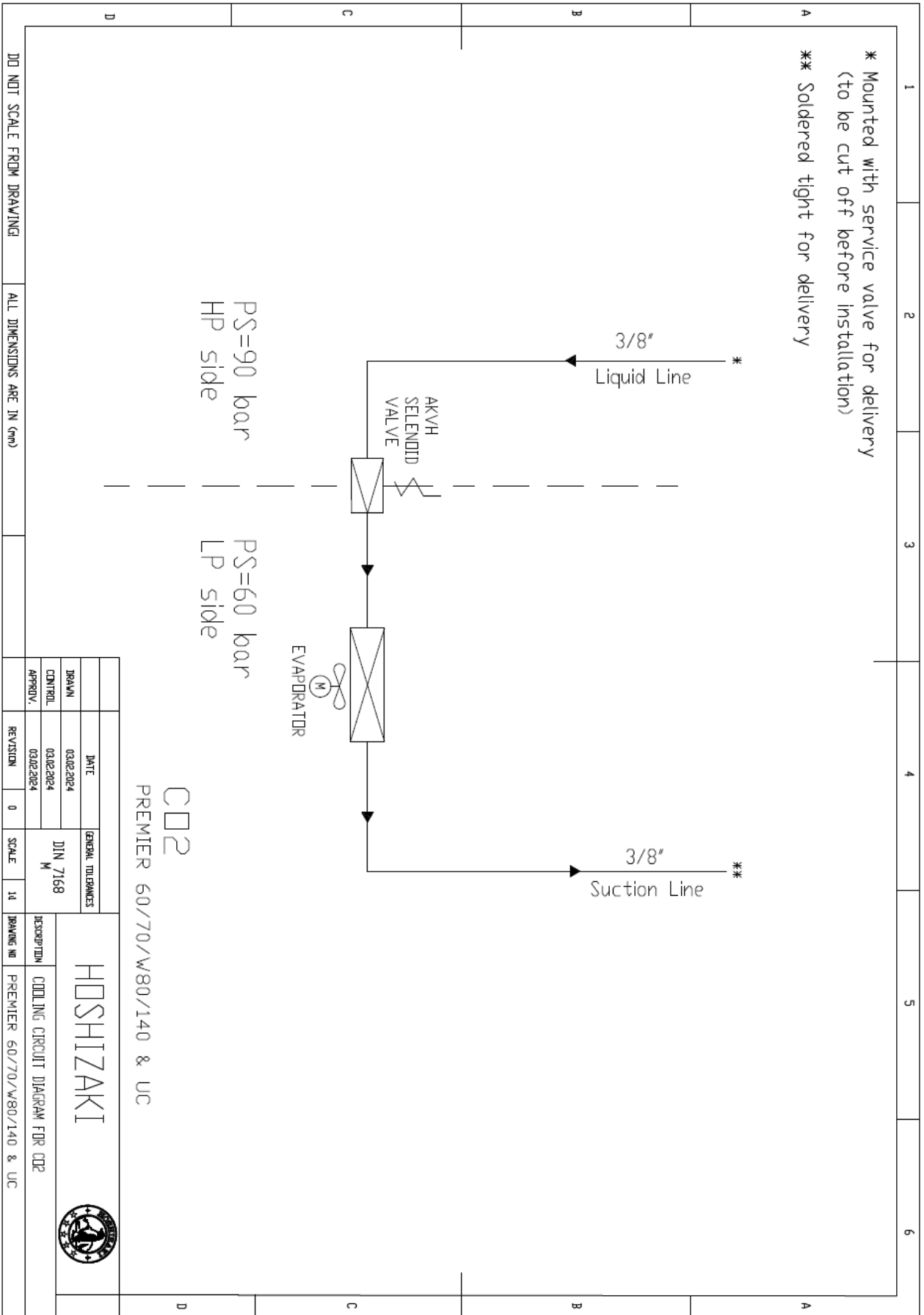



Tutti i diritti riservati

Hoshizaki si riserva il diritto di apportare modifiche alle funzioni e alle informazioni contenute nel presente manuale.

Informazioni di contatto

Sede centrale

Hoshizaki Europe B.V.

TEL: +31 20 691

8499

Sales@hoshizaki.nl

<http://hoshizaki->

[europe.com/](http://hoshizaki-europe.com/)

Filiali

Hoshizaki UK - Regno Unito, Irlanda

TEL: +44 845 456 0585

uksales@hoshizaki.co.uk

Hoshizaki Deutschland - Germania, Svizzera, Austria

TEL: +49 2154 92810, +49 5066 604612

info@hoshizaki.de

Hoshizaki BENELUX - Paesi Bassi, Belgio, Lussemburgo

TEL: +31 20 565 0420, +31 54 645 4252

sales@hoshizaki.nl

Hoshizaki France - Francia

TEL: +33 1 48 63 93 80

info@hoshizaki.fr

Hoshizaki Iberia - Spagna, Portogallo

TEL: +34 93 478 09 52

info@hoshizaki.es

Hoshizaki Middle East - Medio Oriente

TEL: +971 48 876 612

sales@hoshizaki.ae

Hoshizaki Danmark – Danimarca, Norvegia, Svezia

TEL: +45 8988 5350

salg@hoshizaki.dk

Hoshizaki Europe B.V – Tutti gli altri paesi di Europa e Africa

TEL: +31 20 565 0420

sales@hoshizaki.nl

HOSHIZAKI

Premier Remote Cabinets



RU1 OCH CO2 FJÄRRSTYRDA SKÅP HANDBOK FÖR ANVÄNDNING, UNDERHÅLL OCH INSTALLATION



Kontaktuppgifter:

HOSHIZAKI EUROPE B.V.

Adress: Burgemeester Stramanweg 101 1101 AA Amsterdam, Nederländerna

Tel: +31 (0)20 691 84 99 - <http://hoshizaki-europe.com/>





Innehåll

Användning.....	297
Säkerhetsinformation.....	298
Placering	299
Elanslutningar.....	301
Allmän användning	302
Använda produkten (Evco-styrenhet – RU1-modell)	303
Produktens användning (Danfoss-styrenhet AK - CC55)	304
Använda produkten (Carel MPXpro-styrenhet).....	307
Använda produkten (ingen styrenhet – NC-modell).....	313
Felsökning	313
Avfrostningsvatten	314
Dörrens stängningsmekanism	314
Strömavbrott.....	314
Rengöring.....	314
Dörrpackningar	315
Långtidsförvaring	315
Service	315
Tekniska data	316
Mått	318
Avyttring	325
Elektriska kopplingsdiagram	326
Kylschema.....	332



Tack för att du valt en kvalitetsprodukt från Hoshizaki.

I den här bruksanvisningen får du råd om hur du installerar, använder och underhåller den nya produkten.

Innan våra produkter lämnar fabriken genomgår de ett fullständigt funktions- och kvalitetstest. Om du ändå skulle få problem med produkten ska du kontakta en lokal återförsäljare.

Hoshizakis dotterbolag och återförsäljare över hela världen hjälper dig gärna.

Produkter som tillverkas av Hoshizaki omfattas av olika garantivillkor beroende på det land där produkten säljs.

Garantin underkastas korrekt användning enligt specifikationerna, till exempel att vanligt underhåll och eventuella reparationer utförs av tekniker utsedda av återförsäljaren som har allmänna kunskaper om produkten.

Ändringar av installationen och all annan användning av produkten än vad som anges i den här bruksanvisningen kan påverka produktens drift och hållbarhet.

Bruksanvisningen är skriven utifrån vårt aktuella tekniska kunnande. Vi uppdaterar ständigt informationen och förbehåller oss rätten att göra tekniska ändringar.

Användning

Produkten är avsedd för förvaring av livsmedel i andra miljöer än hushåll.

Produkten är avsedd för förvaring vid en konstant temperatur och kan inte användas för att kyla eller frysa varma/färska livsmedel.

Produkten är enbart avsedd att användas för det ändamål som den utformats för. All annan användning kan göra att livsmedlen som förvaras i produkten inte förvaras vid rätt temperatur eller att produkten skadas.

Produkten är inte lämplig för förvaring av blodplasma, laboratorieprover, läkemedel och liknande substanser.

Tillverkaren ansvarar inte för skador som uppstår på grund av felaktig, olämplig eller orimlig användning av produkten.

Säkerhetsinformation

Viktigt

Beskrivning av symboler som används i den här bruksanvisningen.



Varning Om instruktionerna inte följs kan det leda till olyckor med personskador.



Viktigt Om instruktionerna inte följs kan produkten skadas eller förstöras.

Observera att Hoshizaki har vidtagit försiktighetsåtgärder för att säkerställa att produkten är säker.

Läs noga följande information angående säkerhet.



Det är viktigt att alla som ska använda eller installera produkten har tillgång till den här bruksanvisningen.



Enheten är inte avsedd för användning av personer med nedsatta fysiska, sensoriska eller kognitiva förmågor, eller brist på erfarenhet och kunskap, om de inte har fått handledning eller anvisningar om hur enheten ska användas av en person som ansvarar för deras säkerhet.



Barn bör hållas inom uppsyn så att de inte leker med enheten.



Enheten kan innehålla delar med vassa kanter i kompressorutrymmet och det inre facket.



Enheten ska inte transporteras på en säckkärra, det finns risk att den blir ostadig och utgör en fara för andra personer.



Dra inte i strömssladden när enheten kopplas bort eller flyttas.

Placering

Kontrollera om förpackningsmaterialet är skadat när produkten tas emot.

Om förpackningsmaterialet är skadat kan produkten också vara skadad. Kontakta återförsäljaren om skadan är omfattande.



Minst 2 personer behövs för arbetet. Överdelen är den tyngsta delen av produkten. Tänk på det när transportpallen tas bort.



På grund av produktens höga vikt kan golvet skadas eller repas när produkten flyttas.



Korrekt installation är lika med effektiv drift.



Produkten ska placeras i ett torrt rum med tillräcklig ventilation.



För effektiv drift får produkten inte placeras i direkt solljus eller intill ytor som avger värme. Produkten är utformad att användas i en omgivningstemperatur mellan +16°C och +40°C.



Undvik att placera produkten i en miljö som innehåller klor/syra (badhus osv.) på grund av korrosionsrisk.



Produkten och delar på insidan är utrustade med en skyddsfilm som bör tas bort före användning.



Rengör produkten med en mild tvällösning före användning.

Installationsplatsen måste vara plan och vågrät.

På modeller med ben ska de justerbara benen användas för att säkerställa att produkten står plant och upprätt.

På modeller med hjul måste låsanordningarna på de två framhjulen ansättas när produkten är på plats.

HOSHIZAKI

Premier Remote Cabinets



Det måste alltid finnas 500 mm ledigt utrymme ovanför produkten för service. Produkten ska placeras så nära en vägg som möjligt.

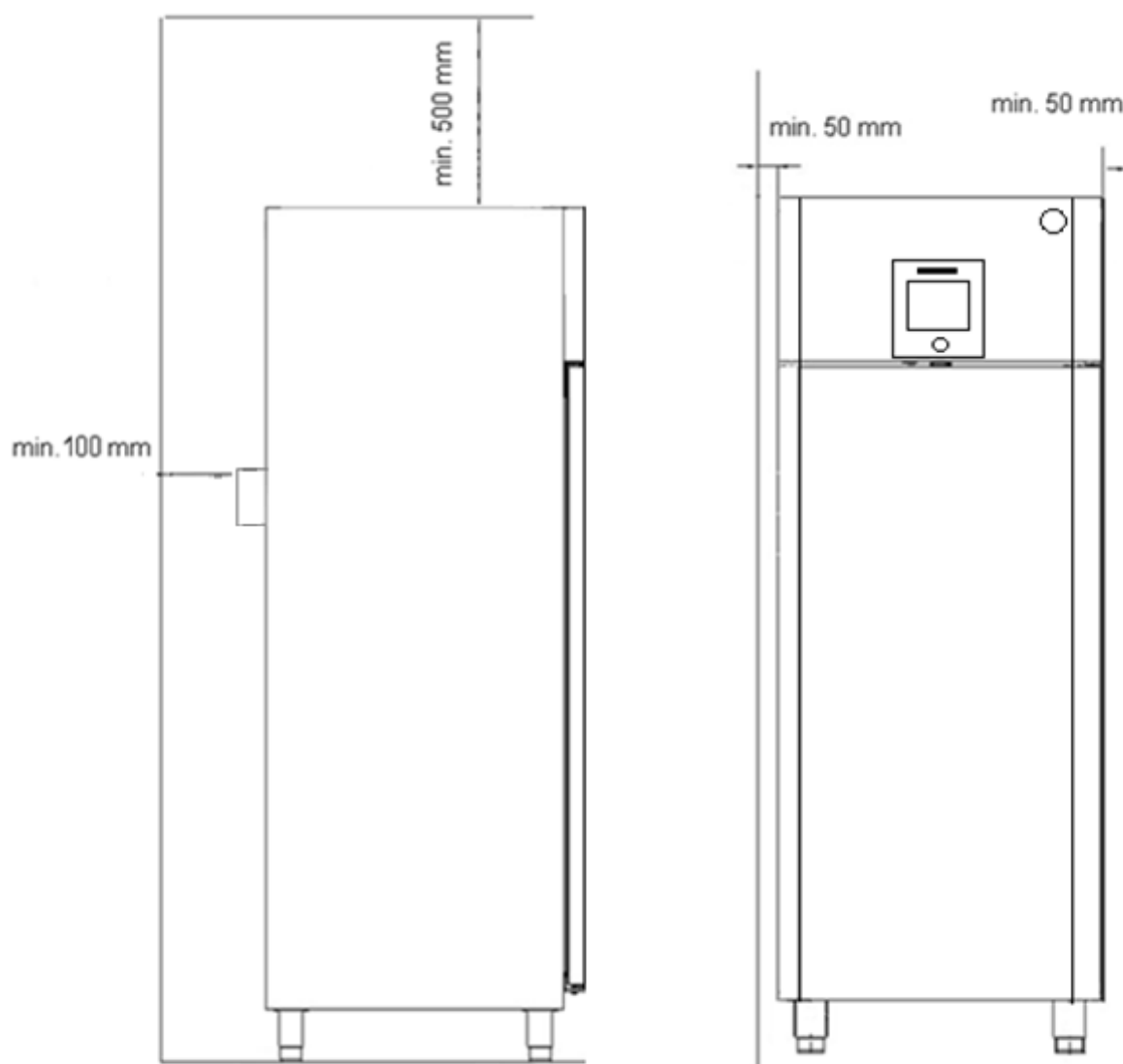

Elanslutningar

Läs noga igenom texten nedan innan elanslutningarna görs.



Produkten är avsedd för anslutning till växelström. Anslutningsspänningen (V) och frekvensen (Hz) visas på skåpets namnskylt



Använd aldrig en förlängningssladd med den här enheten!

Om ett vägguttag är placerat längre bort än längden på den medföljande strömsladden ska du kontakta en elektriker för att montera ett vägguttag som ligger inom räckhåll för strömsladden.



Om det är fel på produkten ska **den undersökas av en kvalificerad servicetekniker** som känner till den installerade styrenheten och har erfarenhet av att underhålla CO2-skåp.



I allmänhet bör den kontrolleras av det företag som anslöt produkten.



Koppla alltid bort strömmen vid strömavbrott, när elektriska delar tas bort/monteras och innan produkten rengörs och underhålls.



Använd bara produkten när alla skyddsdelar är monterade för att undvika kontakt med strömförande och roterande maskindelar

Produkten får inte användas utomhus.



Alla jordningskrav som föreskrivs av lokala myndigheter måste följas. Stickkontakten och vägguttaget måste ha korrekt jordning. Kontakta en elektriker vid behov.



Se till att produkten är avstängd vid uttaget eller att strömsladden är urkopplad innan service utförs på elektriska delar. Det räcker inte att stänga av produkten vid styrenheten.

Allmän användning



Skada inte delarna i kylsystemet.



Om produkten är försedd med en förångningsbricka under skåpet är det viktigt att inte underhålla/rengöra brickan eller värmaren innan skåpet har varit avstängt tillräckligt länge för att säkerställa att förångningsvärmaren har svalnat. Detta för att förhindra risk för brännskador.



Använd inte elektriska enheter inuti skåpet.



För att säkerställa korrekt och effektivt luftflöde i skåpet måste de angivna områdena hållas fria från artiklar.



Alla artiklar som ska förvaras, som inte är inslagna eller förpackade, ska vara täckta för att undvika onödig korrosion av skåpets inre delar.



Om styrparametrarna ändras från standardinställningarna kan det leda till att produkten inte fungerar som den ska och olämpliga temperaturer kan skada artiklar som förvaras i produkten.



Maximal belastning på hylla: 40 kg



Förvara inte explosiva ämnen som sprejflaskor med lättantändligt drivmedel i enheten.



Placera inte produkter under bottenhyllans stöd eller ovanför den översta lastmarkeringen.

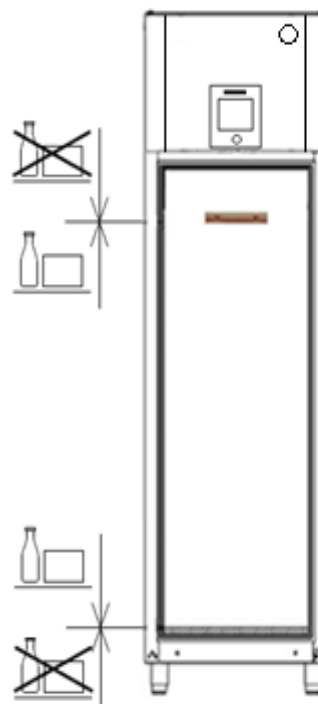

Do not store goods above the top loading mark

Do not store goods below the bottom grate

Använda produkten (Evco-styrenhet – RU1-modell)

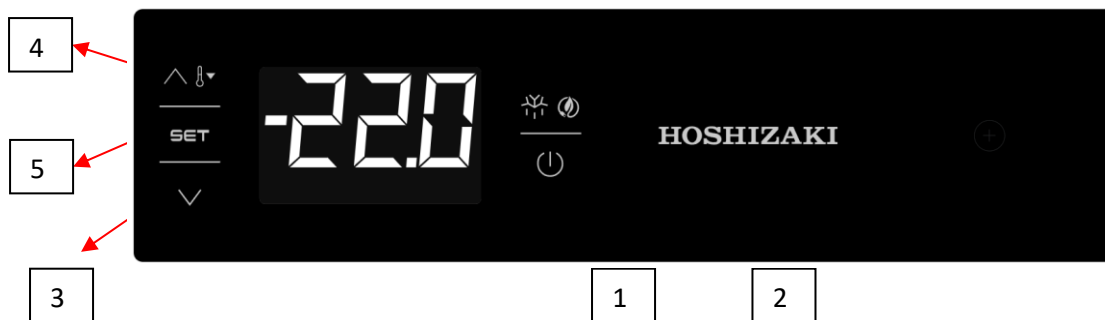

➤ FUNKTIONER PÅ FRONTPANELEN

När du vill låsa knapparna på frontpanelen håller du AUX (3) och På/Standby (1) intryckta i 2 sekunder: "Loc" visas på skärmen när knapparna är låsta och "UnL" visas när de inte är det.

- 1) Enheten öppnas eller stängs när du håller **PÅ/STANDBY** intryckt i 4 sekunder. (På/Av)
- 2) **MANUELL AVFROSTNING**: Manuell avfrostning startar om knappen hålls intryckt i 4 sekunder. Manuell avfrostning startar inte om hög kylning är aktivt och förångarens temperatur inte är lämplig.
- 3) **NED**-knapp: Rullar ned på menyn eller minskar värden. Superkylning aktiveras om den hålls intryckt i 4 sekunder. När hög kylning är aktivt kan den inställda temperaturen minskas. Tiden och temperaturen avgörs med hjälp av parametrarna. Enheten avfrostar aldrig när funktionen för hög kylning är aktiverad.
- 4) **UPP**-knapp: Rullar upp på menyn eller ökar värden. Funktionen för låg och hög relativ luftfuktighet i procent aktiveras om den hålls intryckt i 4 sekunder. (På vissa modeller) "rhL" visas på skärmen när en funktion för låg relativ luftfuktighet i procent används och "rhH" visas på skärmen när en funktion för hög relativ luftfuktighet i procent används. Funktionerna visas på skärmen i 10 sekunder. "----" visas på skärmen i 1 sekund om luftfuktighetsreglering inte är tillgängligt.
- 5) **SET**-knapp: matar in och ändrar värden som kan justeras.

➤ ANVÄNDNING

Exempel på användning anges nedan:

"På"-status: Ström matas och enheten är igång.

"Standby"-status: Enheten är avstängd men ström matas fortfarande.

"Av"-status: Stäng av enheten genom att dra ut kontakten ur uttaget eller stänga av huvudsäkring.

Produktens användning (Danfoss-styrenhet AK - CC55)





Start:

Anslut enheten.

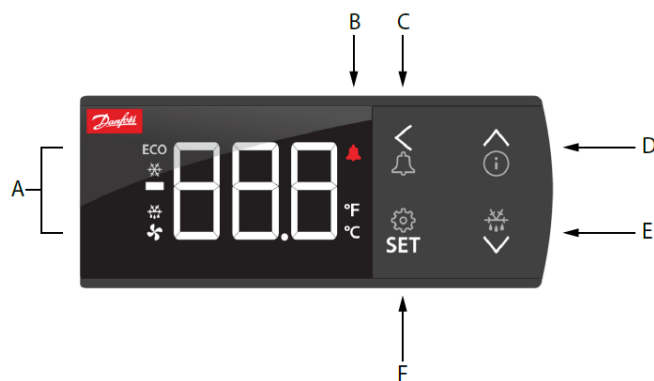
Se till att den 2-poliga huvudströmbrytaren är på.

Förklaring av display (AK-UI55):



Displayens delar	Beskrivning
A	Tänds vid:  – Energioptimering (ECO)  – Kylning  – Avfrostning  – Fläktdrift
B	Lampor i händelse av larm
C	Lång tryckning (3 sekunder) på larmknapp (reläet återställs) larmkod visas
D	Lång tryckning (3 sekunder) öppnar informationsmenyn "Inf" (Se figur "b") Uppil/nedpil/vänsterpil: Navigering på menyn och inställning av värden.
E	Lång tryckning (3 sekunder) startar avfrostning, "-d-" visas på displayen. En pågående avfrostning kan stoppas med ett långt tryck.
F	SET: Lång tryckning (3 sekunder) öppnar menyn "SET". Om driften spärrats med ett lösenord visas "PS". Ange koden. * Visar inställningen för en vald parameter/sparar en ändrad inställning. Ett kort tryck öppnar termostatens avstängningsgräns.

* Fabriksinställningen för P89 är 0. Detta steg hoppas över om indatavärden saknas.



a- parameterlista för "SET"-knapp b - parameterlista för "Info"-knapp

SET	←	SET button, 3 s: Configuration settings
Set		
(PS) v	←	PS: Password (if any)
cFg	SET →	
v		
r--		
A--		
c--		
d--		
n--		
F--		
t--		
h--		
o--		
p--		
q--		
u--		
<		
(Return)		

r12	Main switch
o61	Application
o03	MODBUS address
r89	Food type
r00	Cut-out temperature
r15	Ther. sensor S4 %
r61	Ther. sensor S4% night
A36	Alarm sensor S4%
o17	Display air S4%
o30	Refrigerant type
o20	Min. transmitter range
o21	Max. transmitter range
d01	Defrost method
d03	Defrost interval
d10	Defrost sensor
d04	Max. defrost time
d02	Defrost stop temperature
<	
(Return)	

Menu groups
See also the following pages.

^	←	Info button, 3 s: Information for service use
Inf		
StA	SET	See control state message
App	SET	See selected application
in	SET →	
out	SET →	
buS	SET	MODBUS quality
SoF	SET	See SW version
<		
(Return)		

do1	*	Read output status
do2	*	
do3	*	
do4	*	
Ao1	**	
<		(Return)

Al1	(PE)	Read input status
Al2	**	
Al3	**	
Al4	**	
Al5	**	
di1	**	
di2	**	
<		(Return)

Output status
When you want info on a relay output, the dot will show whether the relay is activated (energized) for e.g.:
do4 = not activated
do.4 = activated

Felmeddelanden (larm)



När ett fel inträffar tänds larmlampan på framsidan och larmreläet aktiveras (beroende på prioritet). Om du trycker på larmknappen i 3 sekunder visas larmrapporten på displayen.

Mer information finns i bruksanvisningen för den valda CO2-styrenheten.
(Danfoss AK-CC55 Compact)

Code	Alarm text	Description
E01	Hardware failure	The controller has a hardware failure
E06	Clock lost time	Clock has lost valid time
E20	Pe Evap. pressure A - Sensor error	Sensor signal is out of range. Please check the sensor for correct operation
E24	S2 Gas outlet A - Sensor error	Sensor signal is out of range. Please check the sensor for correct operation
E25	S3 Air ON evap. A - Sensor error	Sensor signal is out of range. Please check the sensor for correct operation
E26	S4 Air OFF evap. A - Sensor error	Sensor signal is out of range. Please check the sensor for correct operation
E27	S5 Evaporator A - Sensor error	Sensor signal is out of range. Please check the sensor for correct operation
A01	High temperature alarm A	The alarm temperature has been above the max alarm limit for a longer time period than the set alarm delay.
A02	Low temperature alarm A	The alarm temperature has been below the min alarm limit for a longer time period than the set alarm delay.
A04	Door open alarm	The door has been open for a too long time
A05	Max defrost hold time exceeded	The controller has been waiting longer time than permitted after a co-ordinated defrost.
A11	Refrigerant not selected	The refrigerant has not been selected hence control can not be initiated
A15	DI alarm 1	Alarm signal from digital input signal
A16	DI alarm 2	Alarm signal from digital input signal
A45	Main switch set OFF	The controller main switch has been set to either Stop or Manual control. Alternatively a digital input set up for "main switch" function, has stopped control
A59	Case in cleaning mode	A case cleaning operation has been started on a case
AA2	CO ₂ leak detected	CO ₂ is leaking from the refrigeration system
AA3	Refrigerant leak detected	Refrigerant is leaking from the refrigeration system
a04	Wrong IO configuration	Inputs and outputs have not been configured correctly

Använda produkten (Carel MPXpro-styrenhet)

Start

Anslut enheten

Standardinställningen för skåpets styrenhet är att den levereras påslagen. Det innebär att styrenheten startar när strömförsörjningen ansluts och huvudströmbrytaren är i påslaget läge.

Slå på/stänga av skåpet

Slå på/stäng av skåpet med den 2-poliga huvudströmbrytaren på vänster sida av huvudstyrdosan i kompressorutrymmet.

Display





Displayens layout/förklaring:



Skärmen ovan visar tre tecken.

Flera lysdioder finns i avläsningsområdet. Lysdioderna indikerar följande.

I allmänhet = När en LED blinkar är aktiveringen fördröjd eller begränsad.

-  = Kylning på (när LED:n lyser är kylning på)
-  = Inre fläkt igång (när LED:n lyser är den inre fläkten/förångarfläkten på)
-  = Avfrostning på (när LED:n lyser pågår en avfrostningscykel)
-  = Om LED:n blinkar är det en indikation på att dörren är öppen eller att det finns ett aktivt larm eller fel.

HACCP = När LED:n lyser är ett HACCP-larm aktivt. När LED:n blinkar finns ett lagrat HACCP-larm.

Knappar:

De 4 knapparna till höger om displayen används för att komma åt och justera olika parametrar. Knapparna kan tryckas in var för sig eller i kombination för att manövrera styrenheten.

Nedanstående inställningar är de enda som bör ändras av slutanvändaren. Slutanvändaren bör inte ändra parametrar som inte förklaras här. Alla andra inställningar bör göras av en kunnig tekniker.

ANVÄNDARINSTÄLLNINGAR

Justera skåpets börvärde för temperatur



: UPP



: NED



: Set



: Prg/mute

- Håll Set intryckt under normal drift tills displayen börjar blinka. Skåpets börvärde för temperatur kan justeras genom att trycka på upp och ned .
- När börvärdet har justerats till önskad temperatur ska du snabbt trycka in Set för att spara det nya värdet och återgå till normal drift.

Utföra en manuell avfrostning

- Håll def intryckt i mer än 5 sekunder under normal drift när du vill göra en manuell avfrostning och temperaturen för förångarens givare är tillräckligt låg.
- När avfrostningssymbolen  lyser visar det att avfrostning pågår.
- Om def trycks in och hålls intryckt i mer än 5 sekunder när en avfrostningscykel pågår kommer avfrostningen att inaktiveras.

Stänga av akustiska larm

- När styrenheten är i larmläge hörs en akustisk signal. Larmet kan stängas av genom att trycka på Prg/mute .



Ställa in gränser för temperaturlarm

- Håll Prg/mute intryckt i mer än 5 sekunder under normal drift för att öppna parameterlistan. Displayen visar /c1
- Tryck på Prg/mute . Den första parameterkategorin, "Pro", visas
- Tryck på UPP tills kategorin "ALn" visas vilket indikeras av ikonen  som tänds på displayen.
- Tryck på Set parametern AA visas.
- Tryck på UPP tills du kommer till A1
- Tryck på Set för att justera om AL (**A**larm **L**ow temperature threshold) och AH (**A**larm **H**igh temperature threshold) ska vara (0 = relativt till skåpets börvärden för temperatur) eller (1 = absolut). Standardinställning = 1
- Tryck på Set för att spara den valda inställningen och återgå till A1
- Tryck på UPP tills du kommer till AL (**A**larm **L**ow temperature threshold)
- Tryck på Set så att du kan justera AL med upp och ned (justerbart mellan -50 och +50). Standardinställning = -50 °C
- tryck på Set för att spara den valda inställningen och återgå till AL
- tryck på UPP tills du kommer till AH (**A**larm **H**igh temperature threshold)
- tryck på Set så att du kan justera AH med upp och ned (justerbart mellan -50 och +50). Standardinställning = +50 °C
- tryck på Set för att spara den valda inställningen och återgå till AH
- tryck på UPP tills du kommer till Ad (**A**larm **D**elay time för AL och AH)
- tryck på Set så att du kan justera Ad med upp och ned (justerbart mellan 0 och 240 minuter). Standardinställning = 120 minuter.
- tryck på Set för att spara den valda inställningen och återgå till Ad
- Håll Prg/mute intryckt i mer än 5 sekunder för att spara ändringarna och återgå till huvudmenyn.

Nedanstående exempel på larminställningar rekommenderas för ett kylskåp eller en frys när du anger lämpliga gränser för temperaturlarm och fördröjningstider:

	Börvärde	A1	AL	AH	Ad
Kylskåp	+5 °C	1	+1 °C	+8 °C	120 min.
Frys	-18 °C	1	-50 °C	-15 °C	120 min.

Visa larmloggen

- Tryck på Prg/mute och Set och håll intryckt i 5 sekunder.
- Ange lösenordet: 44.
- Tryck på Set för att öppna en undermeny där du kan bläddra mellan



olika larm, HS0 till HS9, med UPP och NED .

- Välj ett larm och tryck på Set för att visa kod, timme, minuter och varaktighet.
- Om du trycker på Prg/mute i en av underparametrarna återgår styrenheten till den överordnade parametern "HSx".
- Tryck på Prg/mute i 5 sekunder för att återgå till

standarddisplayen. Exempel:

"HI" -> "h17" -> "m23" -> "65"

visar att larmet "HI" (högtemperaturlarmet) aktiverades kl. 17:23 och varade i 65 minuter.

HACCP-LARM

Två typer av HACCP-händelser hanteras:

- larm av typ HA, hög temperatur under drift
- larm av typ HF, hög temperatur efter strömavbrott.

När ett larm registreras blinkar HACCP LED-lampan, displayen visar larmkoden, larmet sparas och larmreläet och ljudsignalen aktiveras.

Visa HA- och HF-larm

- Tryck på Prg/mute och NED samtidigt
- Bläddra i listan över larm genom att trycka på UPP och NED
- Tryck på Set för att välja larm
- Använd UPP eller NED för att se beskrivningen av larmet: år, månad, dag, timmar, minuter och varaktighet i minuter för det valda larmet
- Tryck på Prg/mute igen för att återgå till den föregående listan.

Med HACCP-larmmenyn kan du även göra följande:

Ta bort ett HACCP-alarm

- Tryck på Set och NED i 5 sekunder när listan över larm visas.

Det gör att HACCP blinkar, displayen visar meddelandet rES och övervakningen av HACCP-larm initieras igen



Så här tar du bort hela HACCP-larmminnet

- Tryck på Set och UPP och NED i 5 sekunder.

Den här proceduren visar meddelandet rES, raderar hela larmminnet och initierar övervakningen av HACCP-larm igen.



































Om du vill använda HACCP-larmen måste realtidsklockan justeras av installationsföretaget innan skåpet överlämnas till slutanvändaren. Dessa justeringar skyddas av en åtkomstkod och kan därför inte göras av slutanvändaren.

Skåpbelysning

På alla skåp är skåplampan placerad på skåpets utsida, ovanför dörren. Lampan drivs av huvudstyrenheten vilket innebär att dess funktion inte kan ändras.

När skåpdörren öppnas tänds lampan ovanför dörren. Lampan ovanför dörren släcks när skåpdörren stängs.

Fel och larm

Display code	Cause of the alarm	Icon flash on display	Alarm relay	Buzzer	Reset	Compressor	Defrost	Evaporator fans	Continuous cycle	Signalled on tLAN	Network solenoid valve
rE	Control probe fault		ON	ON	automatic	duty setting(c4)	unchanged	unchanged	unchanged	√	-
E1	Probe S1 fault		OFF	OFF	automatic	duty setting(c4)	unchanged	unchanged	unchanged	√	-
E2	Probe S2 fault		OFF	OFF	automatic	unchanged	unchanged	unchanged	unchanged	√	-
E3	Probe S3 fault		OFF	OFF	automatic	unchanged	unchanged	unchanged	unchanged	√	-
E4	Probe S4 fault		OFF	OFF	automatic	unchanged	unchanged	unchanged	unchanged	√	-
E5	Probe S5 fault		OFF	OFF	automatic	unchanged	unchanged	unchanged	unchanged	√	-
E6	Probe S6 fault		OFF	OFF	automatic	unchanged	unchanged	unchanged	unchanged	√	-
E7	Probe S7 fault		OFF	OFF	automatic	unchanged	unchanged	unchanged	unchanged	√	-
E8	Serial probe S8 not updated		OFF	OFF	automatic	duty setting(c4)	unchanged	unchanged	unchanged	√	-
E9	Serial probe S9 not updated		OFF	OFF	automatic	duty setting(c4)	unchanged	unchanged	unchanged	√	-
E10	Serial probe S10 not updated		OFF	OFF	automatic	duty setting(c4)	unchanged	unchanged	unchanged	√	-
E11	Serial probe S11 not updated		OFF	OFF	automatic	duty setting(c4)	unchanged	unchanged	unchanged	√	-
LO	Low temperature alarm		ON	ON	automatic	unchanged	unchanged	unchanged	unchanged	√	-
HI	High temperature alarm		ON	ON	automatic	unchanged	unchanged	unchanged	unchanged	√	-
LO2	Low temperature alarm		ON	ON	automatic	unchanged	unchanged	unchanged	unchanged	√	-
HI2	High temperature alarm		ON	ON	automatic	unchanged	unchanged	unchanged	unchanged	√	-
IA	Immediate alarm from external contact		ON	ON	automatic	duty setting(A6)	unchanged	unchanged	unchanged	√	-
dA	Delayed alarm from external contact		ON	ON	automatic	duty setting(A6) if A7≠0	unchanged	unchanged	unchanged	√	-
dor	Door open for too long alarm		ON	ON	automatic	unchanged	unchanged	unchanged	unchanged	√	-
Etc	Real time clock fault		OFF	OFF	automatic	unchanged	unchanged	unchanged	unchanged	√	-
LSH	Low superheat alarm		OFF	OFF	automatic	OFF	unchanged	unchanged	unchanged	√	√
LSA	Low suction temperature alarm		OFF	OFF	automatic / manual	OFF (paragraph 6.10)	unchanged	unchanged	unchanged	√	√
MOP	Maximum evaporation pressure alarm		OFF	OFF	automatic	OFF	unchanged	unchanged	unchanged	√	√
LOP	Low evaporation temperature alarm		OFF	OFF	automatic	unchanged	unchanged	unchanged	unchanged	√	√
bLo	Valve blocked alarm		OFF	OFF	manual/ disabled with P14=0	unchanged	unchanged	unchanged	unchanged	√	-
Edc	Communication error with stepper driver		ON	ON	automatic	unchanged	unchanged	unchanged	unchanged	√	-
EFS	Stepper motor broken/not connected		ON	ON	automatic	unchanged	unchanged	unchanged	unchanged	√	-
EE	Flash unit parameter error		OFF	OFF	automatic	OFF	not performed	OFF	not performed	√	-
EF	EEPROM operating parameter error		OFF	OFF	automatic	OFF	not performed	OFF	not performed	√	-
HA	Type HA HACCP alarm	HACCP	OFF	OFF	manual	unchanged	unchanged	unchanged	unchanged	√	-
HF	Type HF HACCP alarm	HACCP	OFF	OFF	manual	unchanged	unchanged	unchanged	unchanged	√	-
MA	Communication error with Master (only on Slave)		ON	ON	automatic	unchanged	unchanged	unchanged	unchanged	-	-
u1...u5	Communication error with Slave (only on Master)		ON	ON	automatic	unchanged	unchanged	unchanged	unchanged	-	-
n1...n5	Alarm on unit 1 to 5 in the network		ON	ON	automatic	unchanged	unchanged	unchanged	unchanged	-	-
up1...up5	Upload procedure with errors on unit 1 to 5		OFF	OFF	-	unchanged	unchanged	unchanged	unchanged	-	-
GPE	Error in custom gas parameters		ON	ON	automatic	OFF	not performed	OFF	not performed	√	-



Mer information finns i bruksanvisningen för den valda CO2-styrenheten. (Carel MPX PRO)

Använda produkten (ingen styrenhet – NC-modell)



Se bruksanvisningen som medföljer den installerade styrenheten.

Felsökning

Ljud:

- Kontakta service för hjälp om onormala ljud hörs.
- Driftljud från fläkten är normalt.
- Om ljud hörs från plåtdelar, frontpaneler eller paneler på framsidan kan de vara öppna. Stäng panelerna.

Avfrostning inuti facket:

- Luftfuktigheten är för hög.
- Dörren öppnas för ofta.
- Dörren lämnas öppen för länge.
- Skadad dörrpackning. Kontrollera den noggrant för skador.

Dåliga kylprestanda:

- Omgivningstemperaturen är för hög.
- Dörren öppnas för ofta och/eller är öppen för länge.
- Dörren har lämnats öppen.
- Skadad dörrpackning.
- Temperaturinställningen är för hög.
- För mycket livsmedel i produkten – luftinlopp/utlopp blockeras.
- Varma eller heta livsmedel inuti produkten.
- Avfrostning pågår. Skåptemperaturen kan tillfälligt stiga under avfrostningscykeln, men det påverkar inte maten inuti. Avfrostningslampan lyser.

En del livsmedel är frysta:

- För mycket livsmedel i produkten – luftinlopp/utlopp blockeras.
- Temperaturens börvärde är för lågt.
- Det kan vara fel på förångarfläkten.

Kondens runt dörren:

- Luftfuktigheten är för hög.
- Dörren är inte stängd ordentligt.
- Skadad dörrpackning.
- Parametern för dörrvärmaren har inte justerats korrekt.

För hög energiförbrukning:

- Omgivningstemperaturen är för hög.
- Dörren öppnas för ofta och/eller är öppen för länge.
- Dörren har lämnats öppen.
- Skadad dörrpackning.
- Temperaturens börvärde är för lågt.
- För mycket livsmedel i produkten – luftinlopp/utlopp blockeras.
- Varma eller heta livsmedel sätts in i produkten.
- Produkten är placerad i direkt solljus eller nära ytor som avger värme.
- Standardinställningarna har ändrats.

Avfrostningsvatten

Under avfrostningen producerar produkten vatten som leds in i förångningssystemet genom ett vakuumstycke högst upp i skåpet (Premier-skåp)

Vattnet förångas via ett elektriskt värmeelement och en fläktmotor. I sällsynta fall skapar skåpets användningsmönster mer vatten än vad produkten kan förånga, vilket innebär att vattenspill kan uppstå. Om det händer kan det elektriska värmeelementet drivas på 100 % eller kopplas ur och i stället ansluts vattenröret på baksidan till ett avlopp. Dessa ändringar måste utföras av en kunnig servicetekniker.

Dörrens stängningsmekanism

Dörren är utrustad med ett självstängande system. Om dörren öppnas mindre än 90° stängs den av sig själv. Om dörren öppnas mer än 90° förblir den öppen.

Dörren kan öppnas med fotpedalen. Detta lämnar båda händerna fria när livsmedel placeras i skåpet.

Strömavbrott

Vid strömavbrott kommer styrenheten ihåg temperaturinställningen och startar om produkten när strömmen återställs.

Rengöring

Otillräcklig rengöring gör att produkten inte fungerar med optimala prestanda eller till slut blir defekt.

Före rengöring ska produkten alltid kopplas bort.



Spola inte produkten med vatten, använd inte en vattenstråle eller ångslang eftersom det kan orsaka kortslutningar i elsystemet.



Rengöringsmedel som innehåller klor eller klorföreningar samt andra frätande medel **får inte användas** eftersom de kan orsaka korrosion på skåpets rostfria paneler och förångaren.



Produkten ska hållas fri från damm och smuts. Det sker bäst med en dammsugare och en borste.



Använd polish för rostfritt stål när utsidan underhålls.



Produkten ska rengöras invändigt med en mild tvållösning med lämpliga intervall och noggrant kontrolleras innan den tas i drift igen.



Dörrpackningar

Det här kapitel handlar om vikten av väl fungerande dörrpackningar.

Packningar är en viktig del av kylskåp/frysar. Tätningen i skåpet minskar om packningarna försämras. Sämre tätning kan orsaka högre luftfuktighet, intern isbildning, is på förångaren (vilket leder till minskad kylkapacitet) och i värsta fall kortare livscykel för skåpet.



Därför är det viktigt att känna till packningens skick. Regelbunden inspektion rekommenderas.

Packningen ska rengöras regelbundet med en mild tvållösning.

Kontakta leverantören om en packning behöver bytas ut.

Långtidsförvaring

Om produkten har tagits ur drift och ska förberedas för långtidsförvaring ska du rengöra insidan, dörren och dörrpackningen noga med en trasa som fuktats i varm tvållösning. Eventuella matrester kan orsaka mögel.

Service

Om kylningen inte fungerar ska du först kontrollera om enheten av misstag har kopplats bort eller stängts av vid uttaget eller om en säkring har gått.

Om det inte går att hitta orsaken till kylfelet ska du kontakta installatören.

När du kontaktar HOSHIZAKI eller installatören ber vi dig uppge namn och serienummer inuti skåpet. Uppgifterna finns på namnskylden.

Tekniska data

Dekalens placering:

PRODUCT DESCRIPTION LABEL		
1 Product Number		
2 Product Description		
3 Model		
4 Refrigerant (GWP)		
5 CO2 Equivalent		
6 IP Protection		
7 Climate Class		
8 Production Date		
9 Total power / Current / Lamp power		
10 Voltage - Frequency		
11 Heating Element		
12 System Pressure		
13 Blowing Agent		
14 Serial Number		



PRODUCT NUMBER	1
PRODUCT DESCRIPTION	2
MODEL	3
REFRIGERANT	4
CO2 EQUIVALENT	5
IP PROTECTION	6
CLIMATE CLASS	7
PRODUCTION DATE	8
TOTAL POWER / CURRENT / LAMP POWER	9
VOLTAGE - FREQUENCY	10
HEATING ELEMENT	11
SYSTEM PRESSURE	12
BLOWING AGENT	13

S/N: 14

HOSHIZAKI EUROPE B.V. Burgemeester Stramanweg 101 1101 AA Amsterdam, The Netherlands

Trade mark			HOSHIZAKI			
Model name			PREMIER U 70	PREMIER U 140	PREMIER U 80	PREMIER U 60
Avsedd användning			Storage	Storage	Storage	Storage
Drifttemperatur vid kylning			X	X	X	X
Drifttemperatur vid frysning			X	X	X	X
Skåp för flera användningsområden						
Vertikalt skåp			X	X	X	X
Bänkskåp						
Parametro	Symbol	Unit				
Bruttovolym	VnT	L	700	1400	700	480
Klimatklass			CC5	CC5	CC5	CC5
Matarspänning/frekvens	V / Hz		230 - 50	230 - 50	230 - 50	230 - 50
Köldmedel (CO2-skåp)			CO2	CO2	CO2	CO2
Köldmedel (RU-1-skåp)			HFC / HFO Refrigerant*	HFC / HFO Refrigerant*	HFC / HFO Refrigerant*	HFC / HFO Refrigerant*
Kontaktuppgifter:			HOSHIZAKI EUROPE B.V. Address: Burgemeester Stramanweg 101 1101 AA Amsterdam, The Netherlands Tel: +31 (0)20 691 84 99 - http://hoshizaki.europe.com/			

* Köldmedel som är kompatibla med öppningen (R449A, R448A, R45A osv. Kontrollera databladet för öppningens användning)

HOSHIZAKI

Premier Remote Cabinets



Trade mark			HOSHIZAKI		
Model name			BAKER U 950	BAKER GA 950	PREMIER SF 950
Avsedd användning			Storage	Cooling /Freezing / Storage / Proving	Cooling / Shock Freezing
Drifttemperatur vid kylning			X	X	X
Drifttemperatur vid frysning			X	X	X
Skåp för flera användningsområden				X	X
Vertikalt skåp			X	X	X
Bänkskåp					
Parameter	Symbol	Unit			
Bruttovolym	VnT	L	1000	950	950
Klimatklass			CC5	CC5	CC5
Matarspänning/frekvens	V / Hz		230 - 50	230 – 50	230 – 50
Köldmedel (RU-1-skåp)			HFC / HFO Refrigerant*	HFC / HFO Refrigerant*	HFC / HFO Refrigerant*
Informazioni di contatto:	HOSHIZAKI EUROPE B.V.				
	Address: Burgemeester Stramanweg 101 1101 AA Amsterdam, The Netherlands Tel: +31 (0)20 691 84 99 - http://hoshizaki.europe.com/				

* Köldmedel som är kompatibla med öppningen (R449A, R448A, R45A osv. Kontrollera databladet för öppningens användning)

HOSHIZAKI

Premier Remote Cabinets



Mått

PREMIER U 70

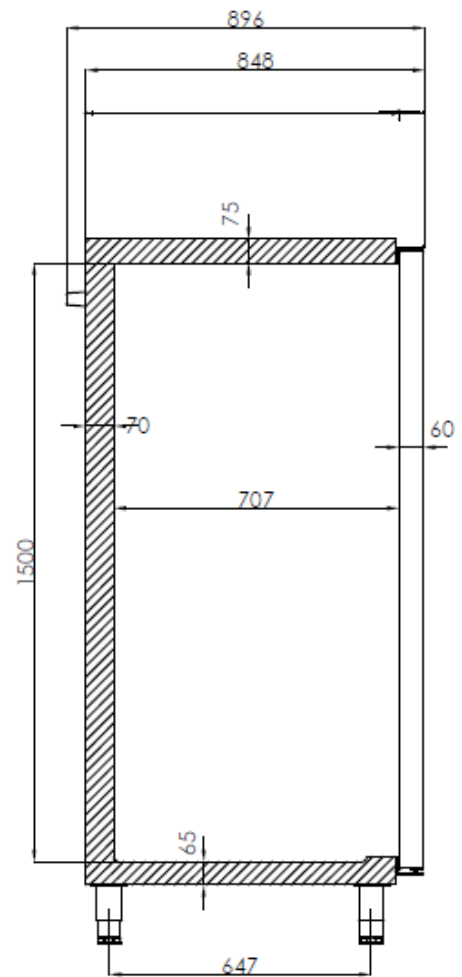
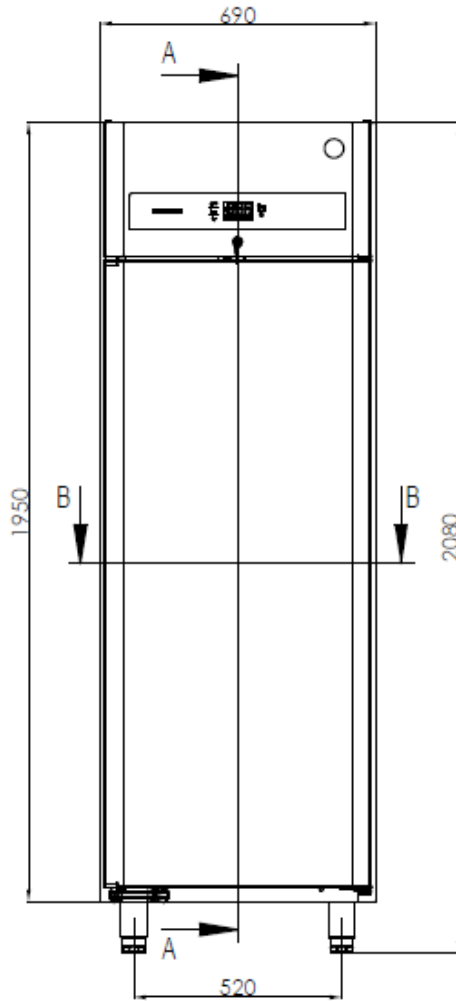

A-A

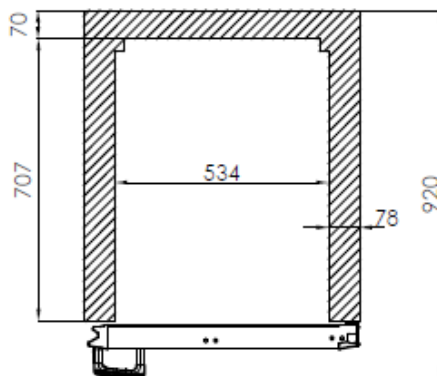

B-B

HOSHIZAKI

Premier Remote Cabinets



PREMIER U 60

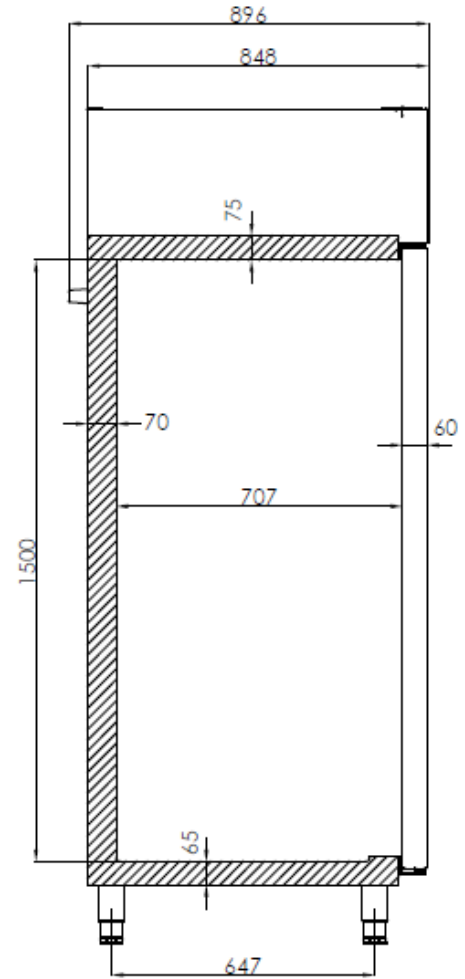
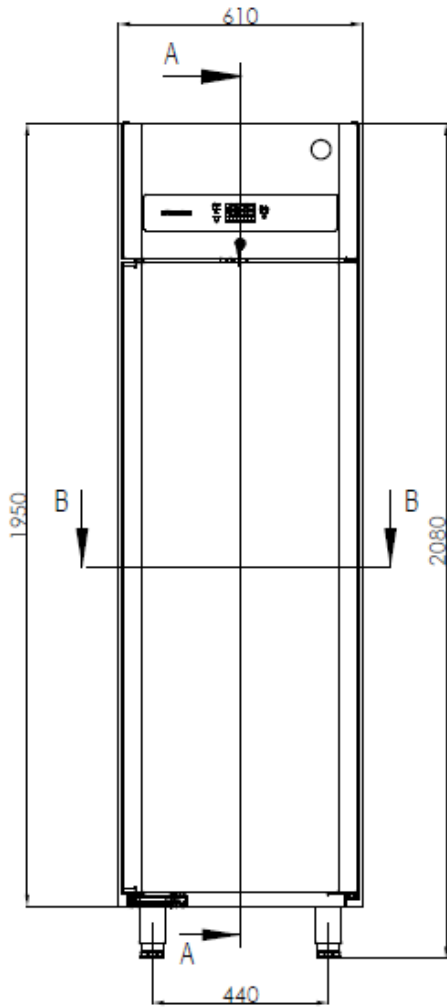

A-A

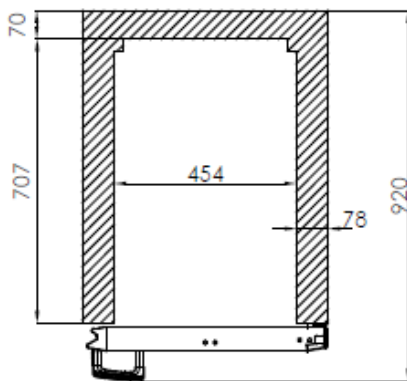

B-B

HOSHIZAKI

Premier Remote Cabinets



PREMIER U 80

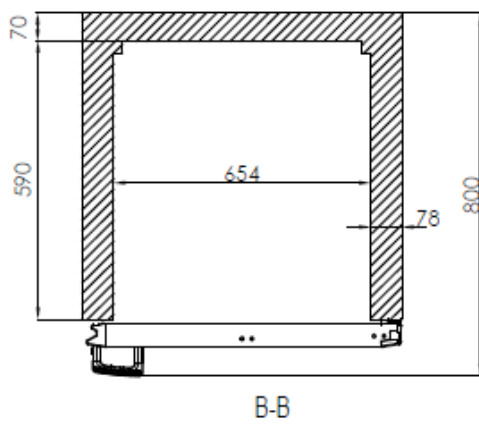
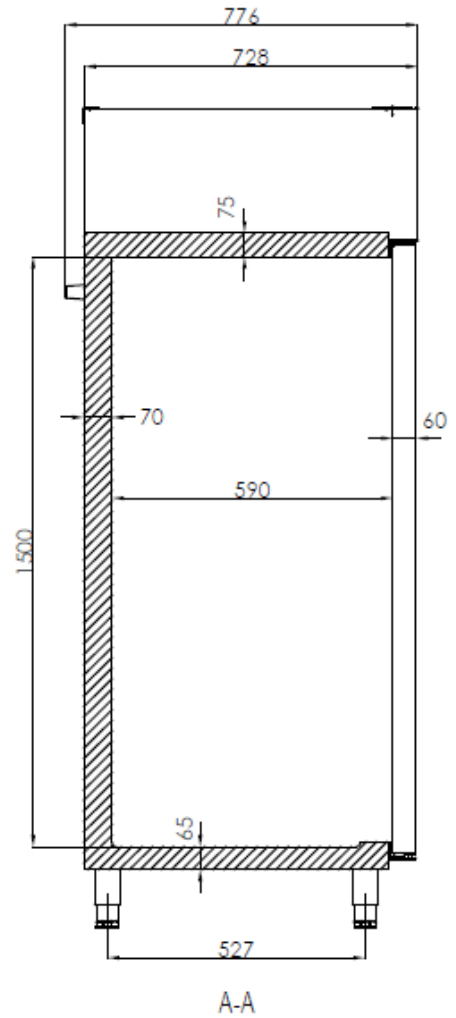
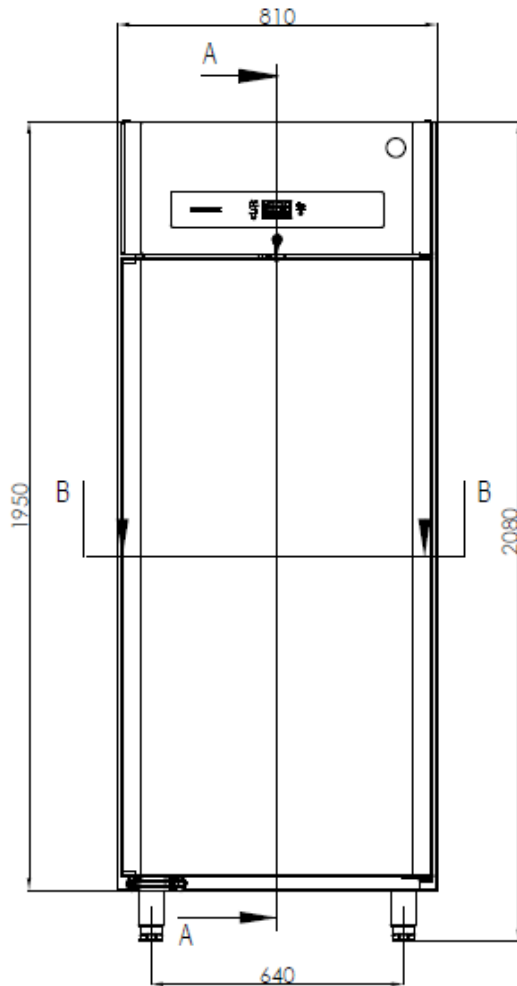

HOSHIZAKI

Premier Remote Cabinets



PREMIER U 140

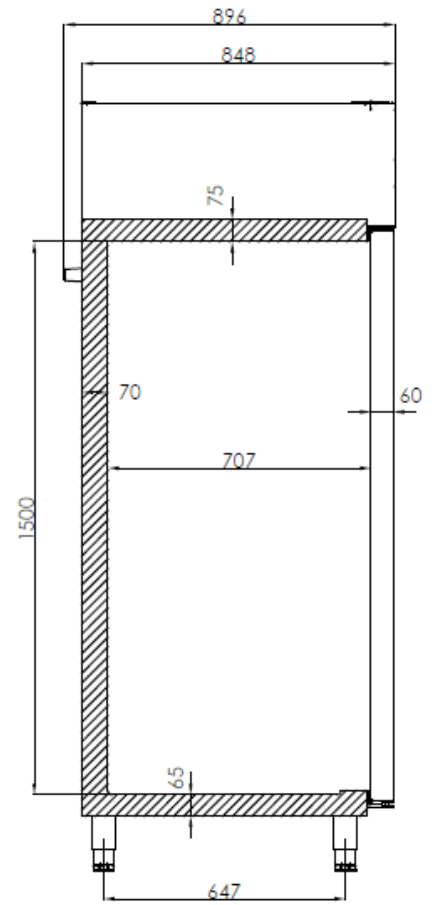
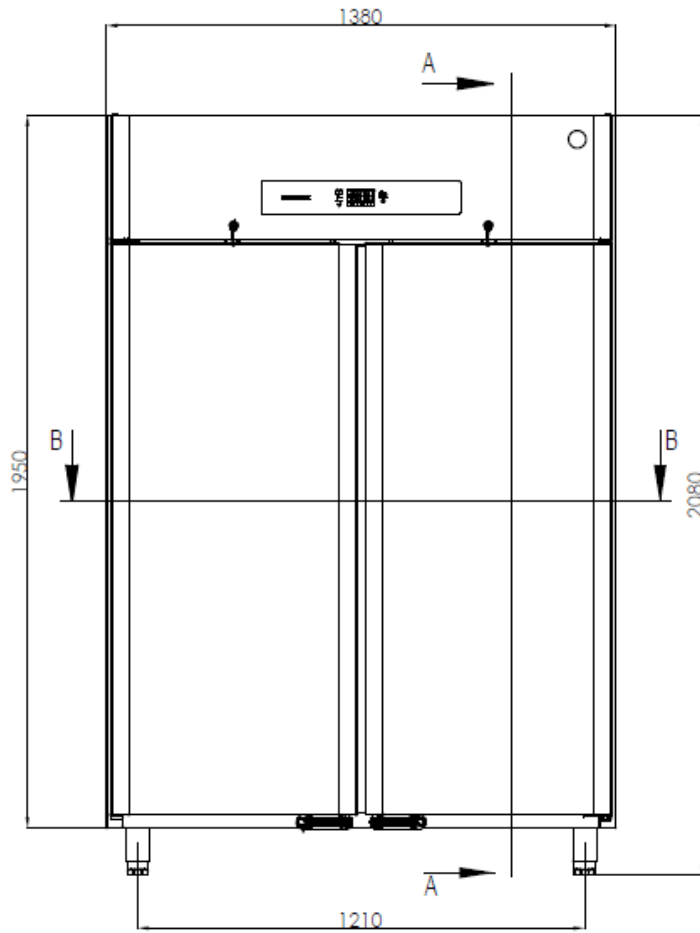

A-A

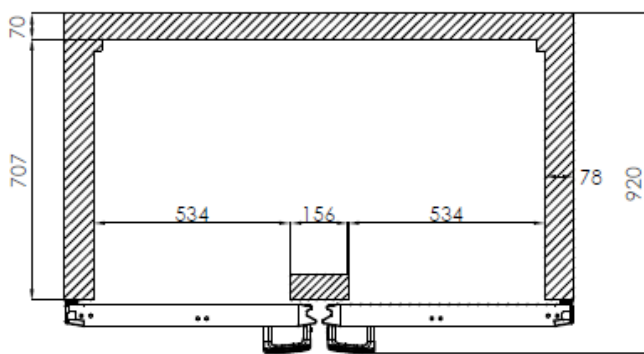

B-B

HOSHIZAKI

Premier Remote Cabinets



BAKER U 950

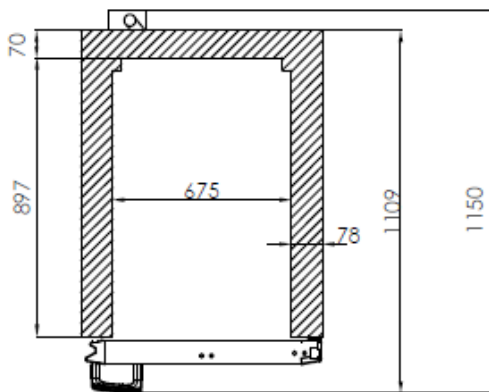
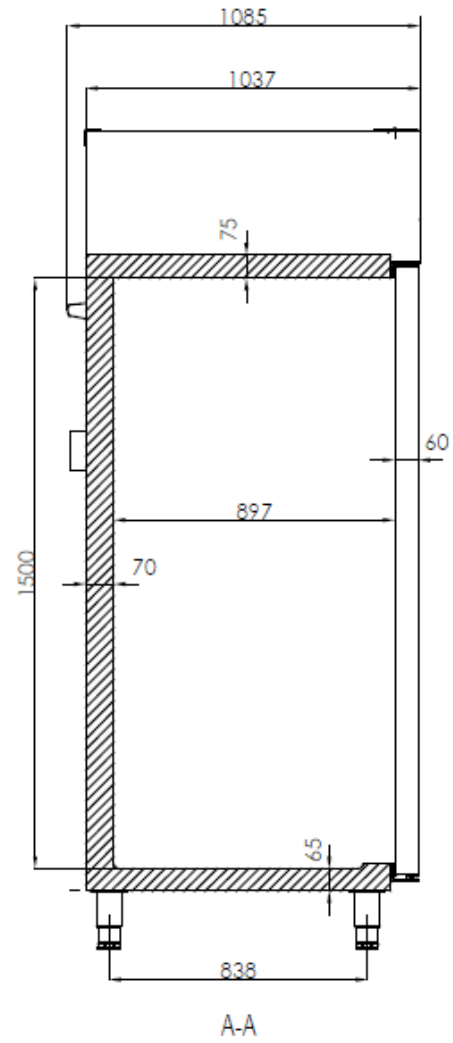
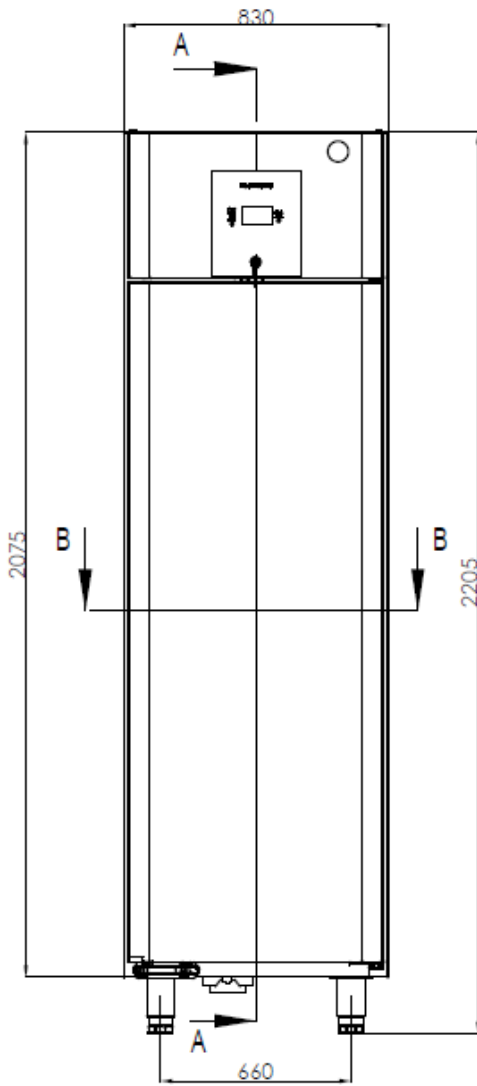

HOSHIZAKI

Premier Remote Cabinets



BAKER GA 950 (RU1)

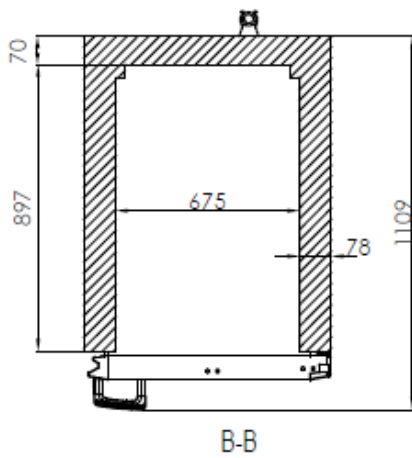
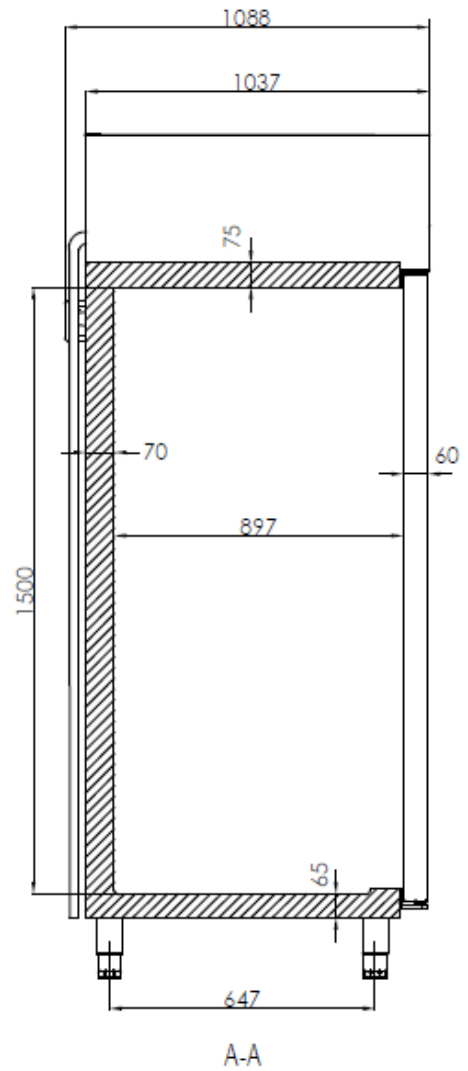
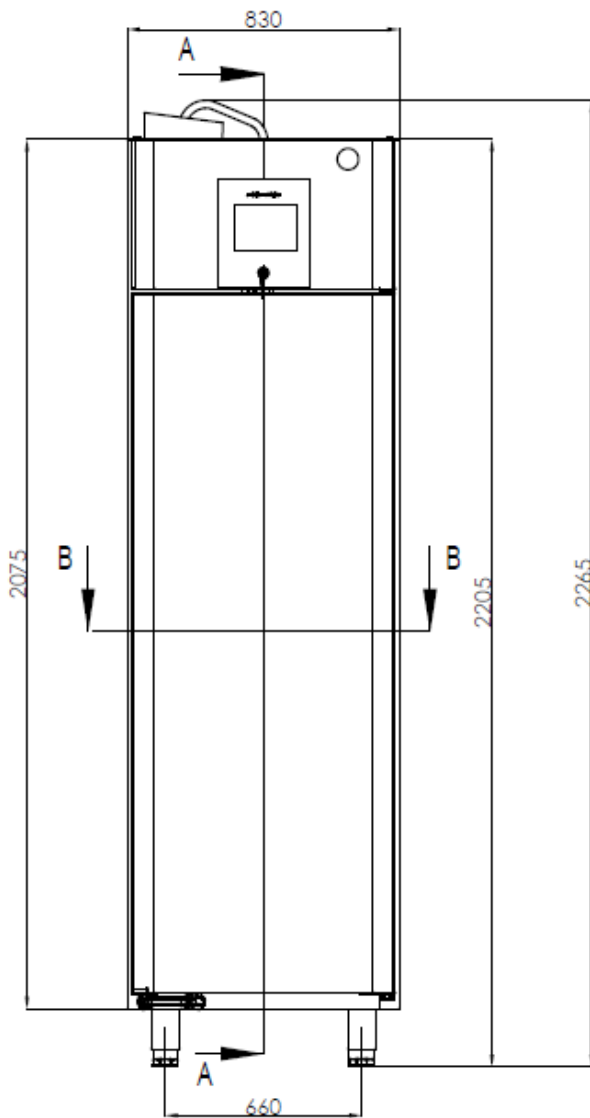

HOSHIZAKI

Premier Remote Cabinets



BAKER SF 950 (RU1)

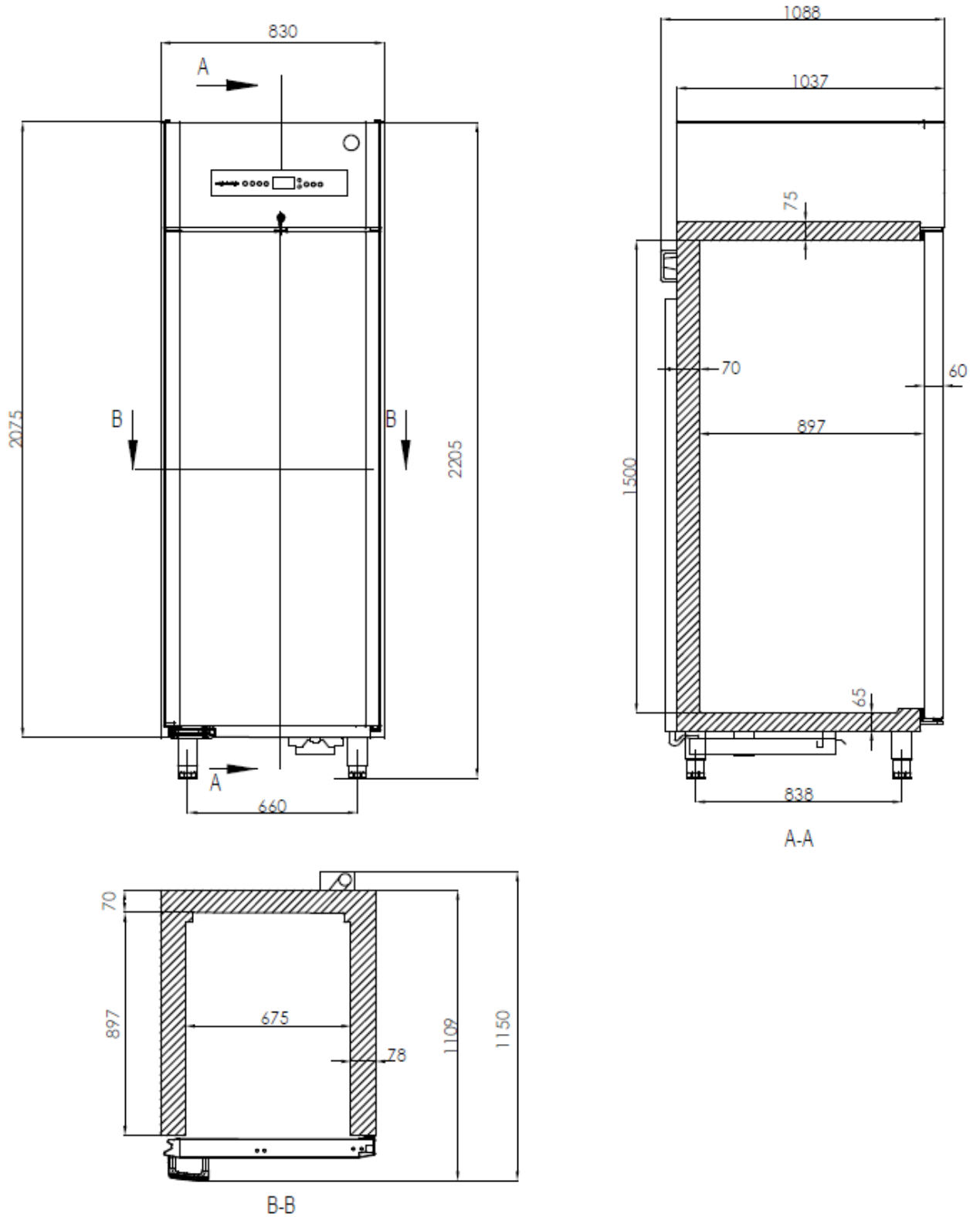

Avyttring

Nedanstående gäller endast Storbritannien.

Kassering av ett gammalt skåp är endast tillgängligt när vi samtidigt levererar ett nytt skåp. Skåpen ska vara helt avfrostade och tömda innan de samlas in.

Hoshizaki inser att produkterna för cateringmarknaden betraktas som WEEE när de blir föråldrade. För att säkerställa att Hoshizakis skyldigheter utförs korrekt och miljövänligt är vi registrerade i Storbritanniens största B2B-efterlevnadssystem – B2B Compliance <http://www.b2bcompliance.org.uk>

B2B Compliance kommer för vår räkning att hantera alla våra skyldigheter vid insamling och bortskaffande av utrustning som omfattas av de brittiska WEEE-reglerna. B2B Compliance kan kontaktas på telefonnummer 01691 676124.





Elektriska kopplingsdiagram

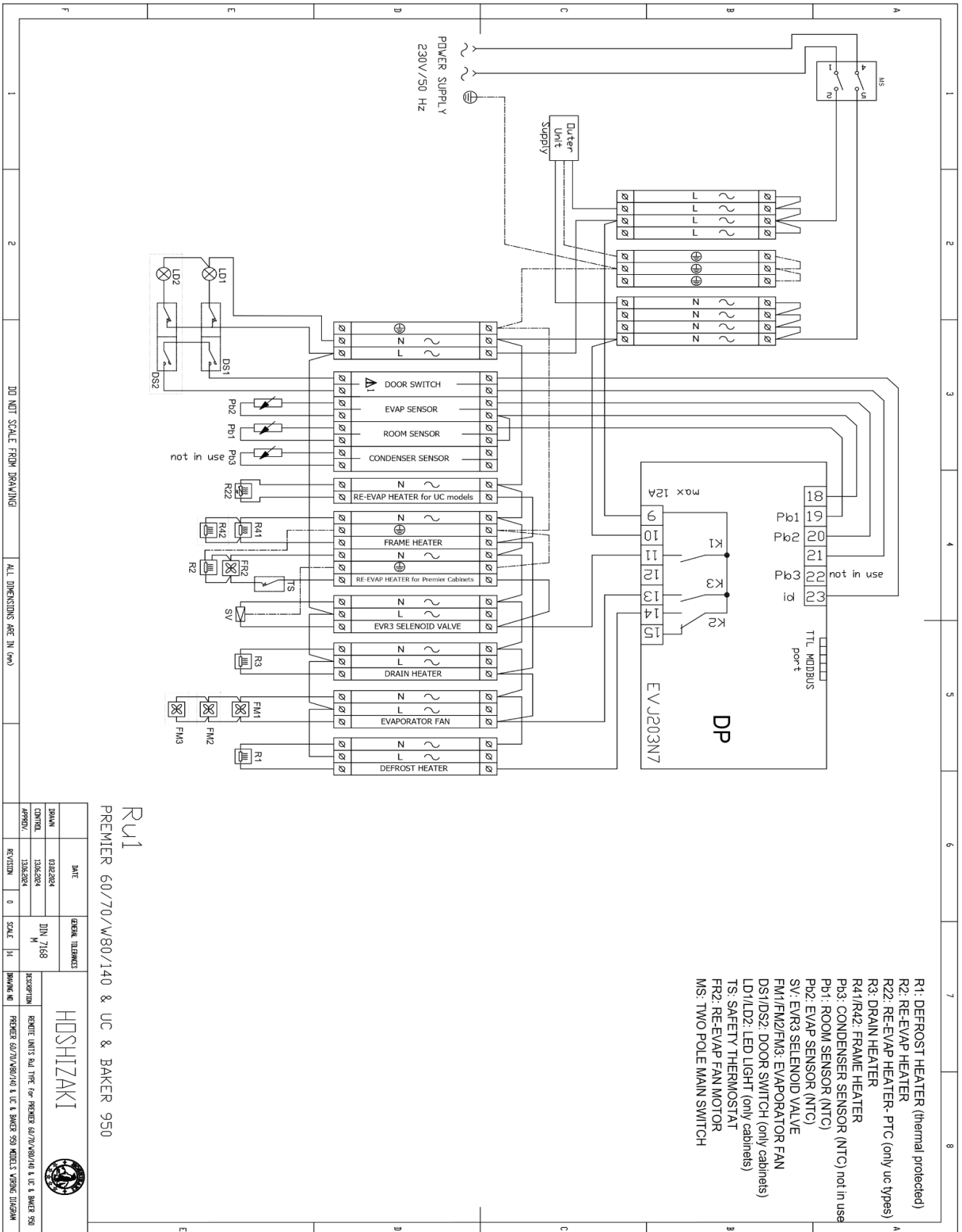

RU1
PREMIER 60/70/W/80/140 & UC & BAKER 950

DATE	GENERAL TOLERANCES	HOSHIZAKI	
DRAWN	DIN 7168		
CONTROL	M		
APPROV.	13582824	DESCRIPTION	
REVISION	0	SCALE	1:1
DRAWING NO		PREMIER 60/70/W/80/140 & UC & BAKER 950 MODEL'S VARIANTE DUSKAM	

HOSHIZAKI Premier Remote Cabinets

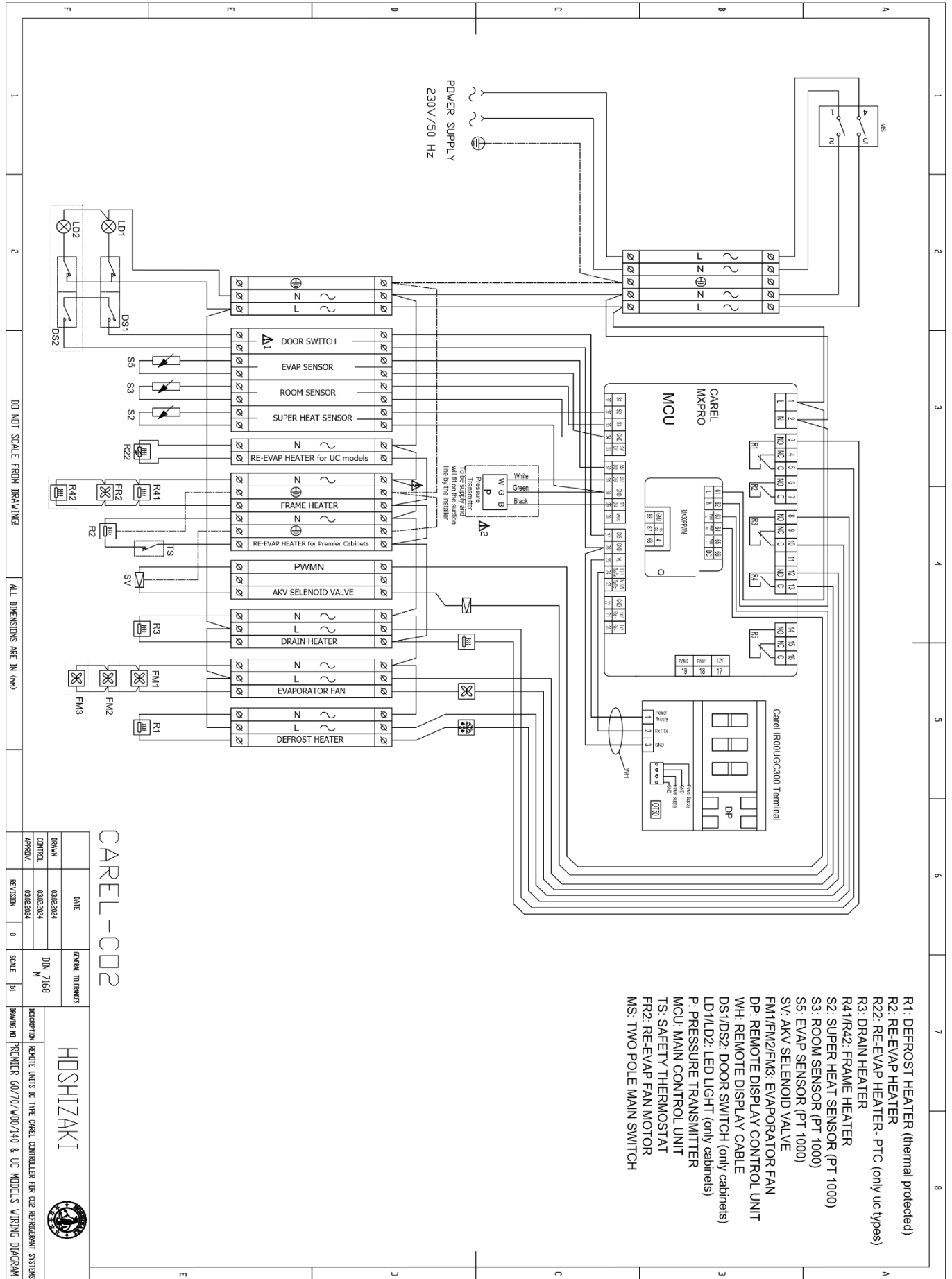

- R1: DEFROST HEATER (thermal protected)
- R2: RE-EVAP HEATER
- R22: RE-EVAP HEATER- PTC (only uc types)
- R3: DRAIN HEATER
- R41/R42: FRAME HEATER
- S2: SUPER HEAT SENSOR (PT 1000)
- S3: ROOM SENSOR (PT 1000)
- S5: EVAP SENSOR (PT 1000)
- SV: AKV SELENOID VALVE
- FM1/FM2/FM3: EVAPORATOR FAN
- DP: REMOTE DISPLAY CONTROL UNIT
- WH: REMOTE DISPLAY CABLE
- DS1/DS2: DOOR SWITCH (only cabinets)
- LD1/LD2: LED LIGHT (only cabinets)
- P: PRESSURE TRANSMITTER
- MCU: MAIN CONTROL UNIT
- TS: SAFETY THERMOSTAT
- FR2: RE-EVAP FAN MOTOR
- MS: TWO POLE MAIN SWITCH

CAREL-C02

DATE	GENERAL TOLERANCES
03.02.2024	DIN 7168
03.02.2024	M
03.02.2024	APPROV.
REVISION	SCALE
0	1:1

HOSHIZAKI



RESERVATION REMOTE UNITS IN THE CAREL CONTROLLER FOR CO2 REFRIGERANT SYSTEMS
DRAWING NO. PREMIER 60/70/W80/140 & UC MODELS WIRING DIAGRAM

DO NOT SCALE FROM DRAWING ALL DIMENSIONS ARE IN (mm)

HOSHIZAKI

Premier Remote Cabinets

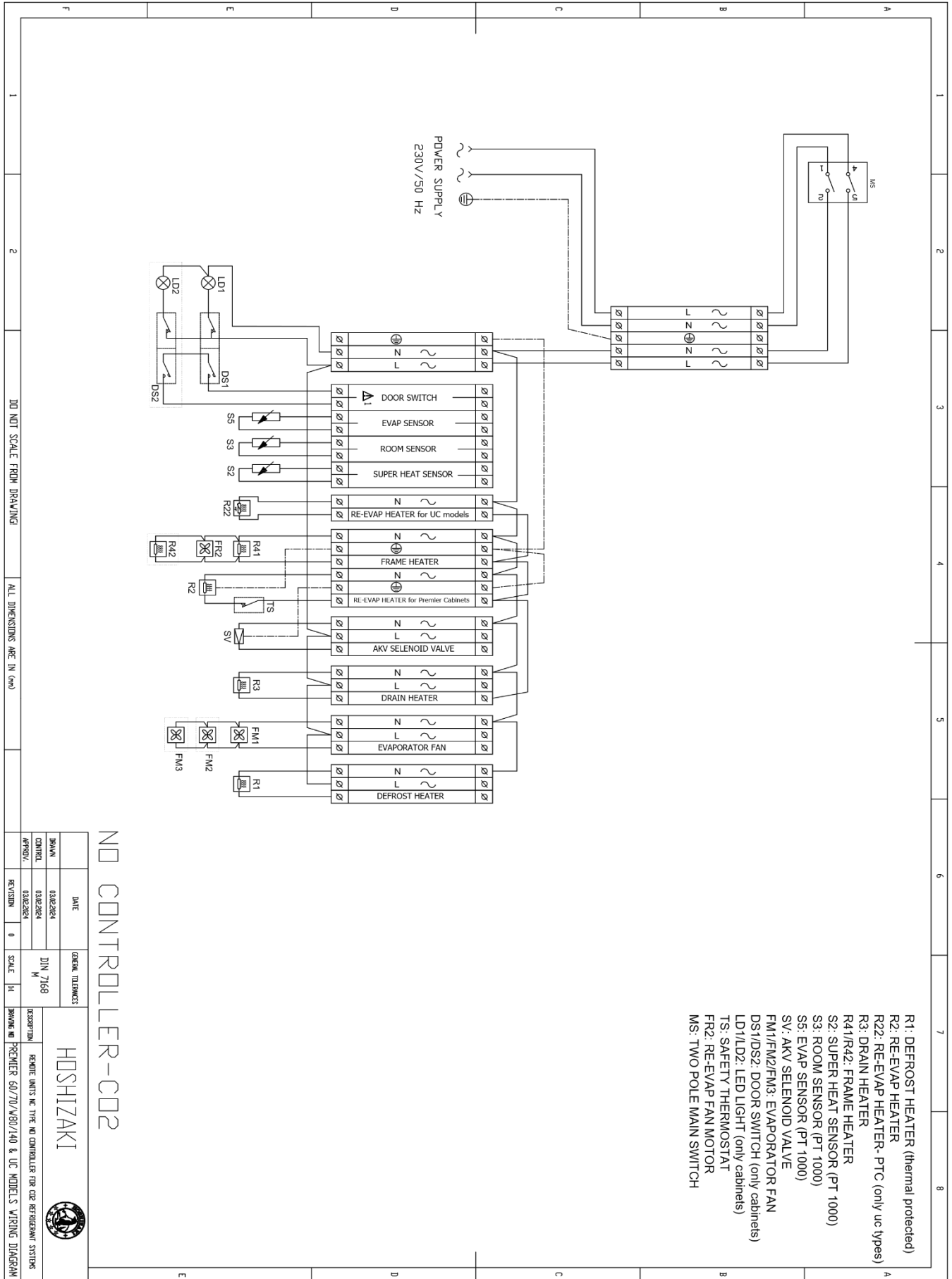

DO NOT SCALE FROM DRAWING

ALL DIMENSIONS ARE IN (mm)

DATE	03/02/2024	GENERAL DIMENSIONS	HOSHIZAKI
DESIGNER	03/02/2024	DIN 7168	
APPROV.	03/02/2024	M	
REVISION	0	SCALE	1:1
DESCRIPTION		PREMIER 60/70/80/140 & UC MODELS WIRING DIAGRAM	





Kylschema

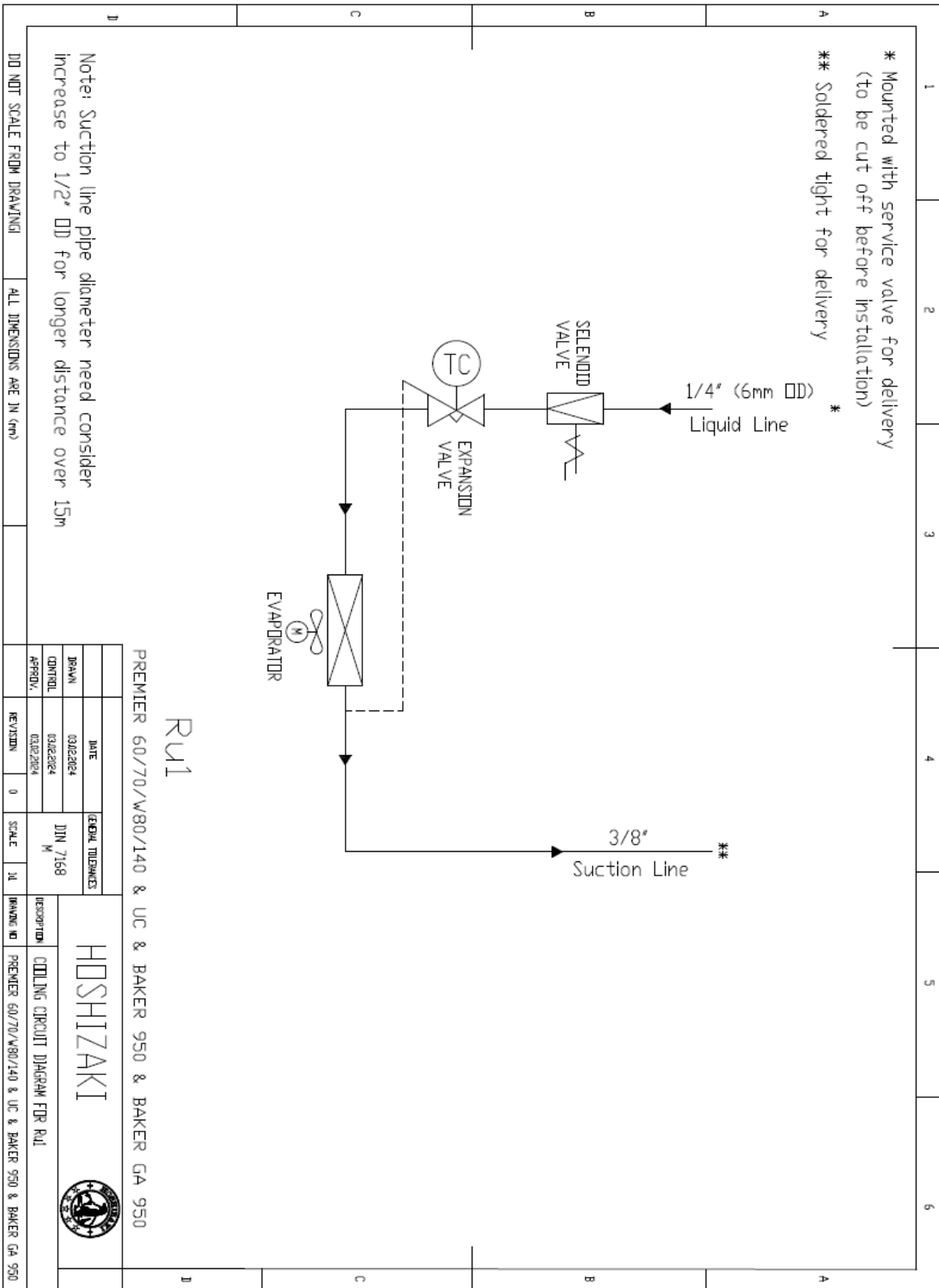

HOSHIZAKI

Premier Remote Cabinets

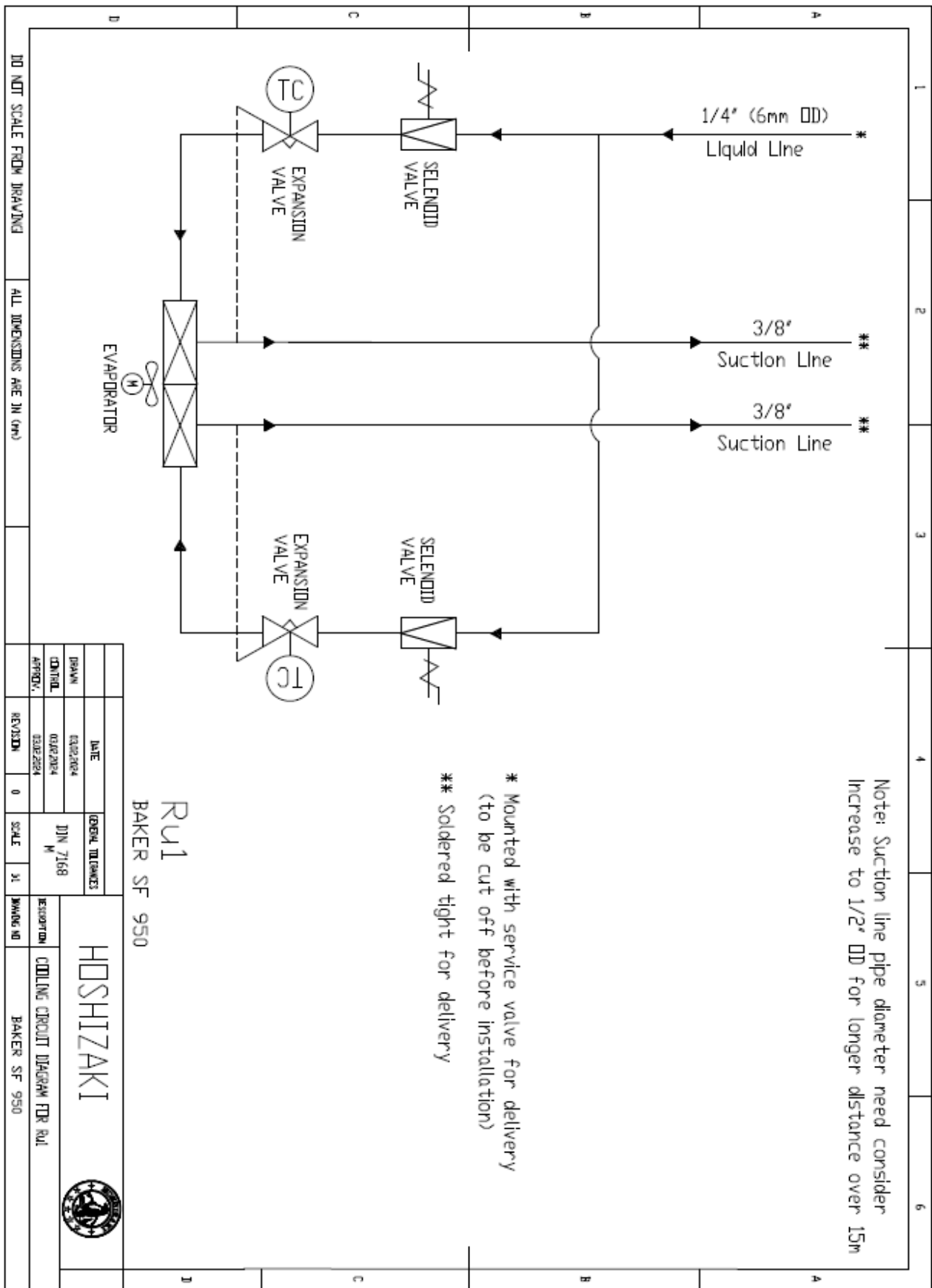



HOSHIZAKI

Premier Remote Cabinets

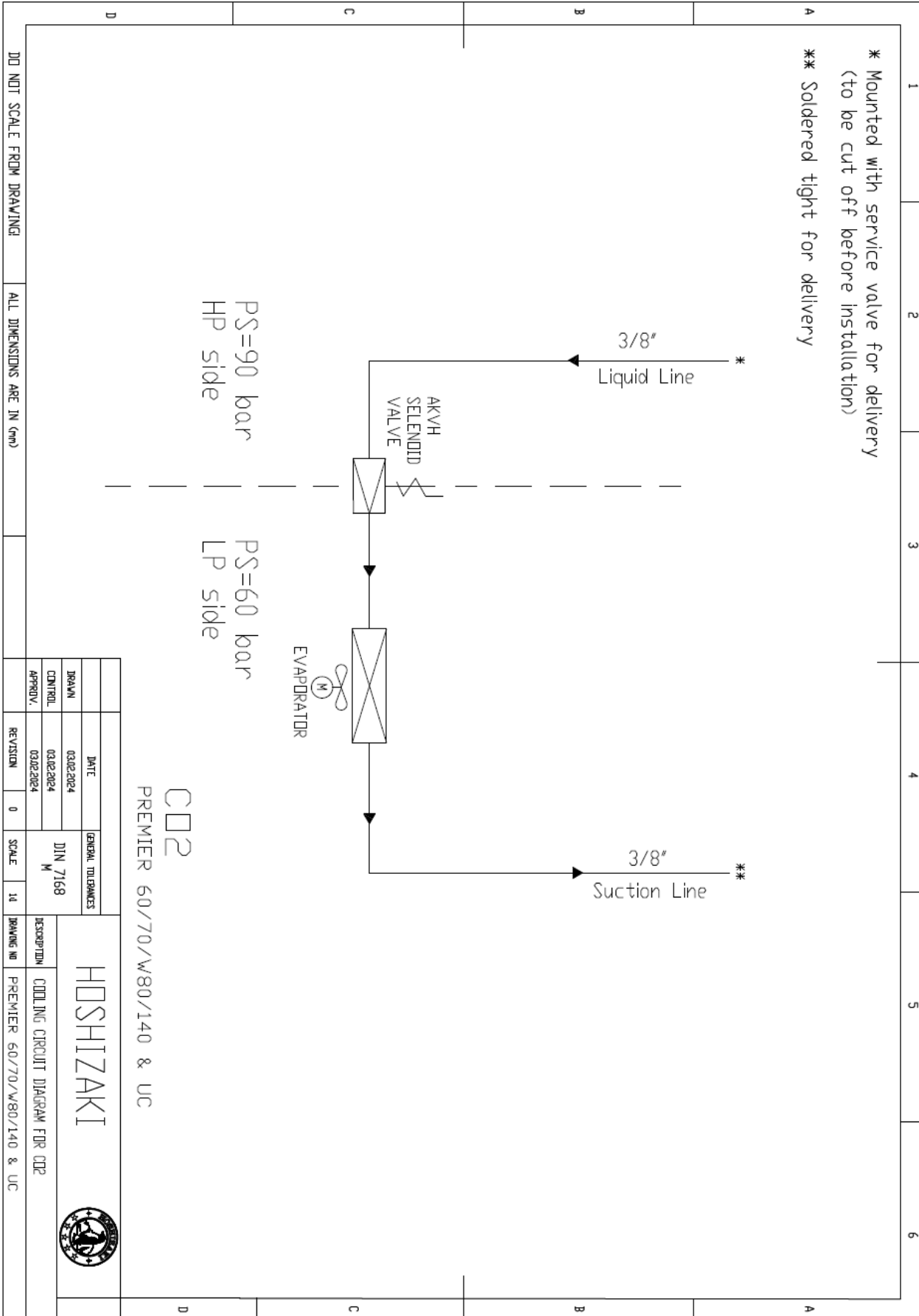

HOSHIZAKI

Premier Remote Cabinets



Med ensamrätt

Hoshizaki förbehåller sig rätten att ändra funktioner och information i den här handboken.

Kontaktuppgifter

Huvudkontor

Hoshizaki Europe B.V.

TEL: +31 20 691

8499

Sales@hoshizaki.nl

<http://hoshizaki->

[europe.com/](http://hoshizaki-europe.com/)

Filialer

Hoshizaki UK – Storbritannien, Irland

TEL: +44 845 456 0585

uksales@hoshizaki.co.uk

Hoshizaki Deutschland – Tyskland, Schweiz, Österrike

TEL: +49 2154 92810, +49 5066 604612

info@hoshizaki.de

Hoshizaki BENELUX – Nederländerna, Belgien, Luxemburg

TEL: +31 20 565 0420, +31 54 645 4252

sales@hoshizaki.nl

Hoshizaki France – Frankrike

TEL: +33 1 48 63 93 80

info@hoshizaki.fr

Hoshizaki Iberia – Spanien, Portugal

TEL: +34 93 478 09 52

info@hoshizaki.es

Hoshizaki Middle East – Mellanöstern

TEL: +971 48 876 612

sales@hoshizaki.ae

Hoshizaki Danmark – Danmark, Norge, Sverige

TEL: +45 8988 5350

salg@hoshizaki.dk

Hoshizaki Europe B.V. – alla andra länder i Europa och Afrika

TEL: +31 20 565 0420

sales@hoshizaki.nl

HOSHIZAKI
Premier Remote Cabinets



MODELL RU1 og CO2 MED FJERNSTYRING DRIFTS-, VEDLIKEHOLDS- OG INSTALLASJONSHÅNDBOK



Kontaktinformasjon:
HOSHIZAKI EUROPE B.V.
Adresse: Burgemeester Stramanweg 101 1101 AA Amsterdam, Nederland
Tlf.: +31 (0)20 691 84 99 - <http://hoshizaki-europe.com/>





Innhold

Bruk	339
Sikkerhetsinformasjon	340
Plassering.....	341
Elektrisk tilkobling	343
Vanlig bruk.....	344
Betjene produktet (Evco-kontrollenhet – RU1-modell).....	345
Betjene produktet (Danfoss-kontrollenhet – AK-CC55)	346
Betjene produktet (Carel MPXpro-kontrollenhet)	349
Betjene produktet (uten kontrollenhet – NC-modell).....	355
Feilsøking	355
Vann ved avriming.....	356
Dørens lukkemekanisme	356
Strøbrudd.....	356
Rengjøring.....	356
Dørpakninger.....	357
Lagring i lang tid	357
Service	357
Tekniske data	358
Mål.....	360
Kassering	367
Koblingsskjemaer	368
Kjøleskjemaer.....	374



Takk for at du valgte et kvalitetsprodukt fra Hoshizaki.

I denne håndboken får du vite hvordan du installerer, bruker og vedlikeholder det nye produktet.

Før produktene sendes fra fabrikken blir funksjoner og kvalitet grundig testet. Dersom du likevel får problemer med produktet, ber vi deg kontakte nærmeste forhandler.

Hoshizakis datterselskaper og forhandlere over hele verden hjelper deg gjerne.

Produkter produsert av Hoshizaki dekkes av ulike garantier som gjelder i landet der produktet ble solgt.

Garantien forutsetter korrekt bruk i henhold til spesifikasjonene, der f.eks. vanlig vedlikehold og eventuelle reparasjoner skal utføres av fagfolk anbefalt av forhandleren og med generell kunnskap om produktet.

Endret installering og annen bruk av produktet enn det som er oppgitt i denne håndboken, kan påvirke driften og holdbarheten til produktet.

Håndboken er skrevet i tråd med vår nåværende tekniske kunnskap. Vi jobber kontinuerlig med å oppdatere denne informasjonen, og vi forbeholder oss retten til å foreta tekniske endringer.

Bruk

Produktet skal brukes til oppbevaring av matvarer på steder utenfor husholdninger.

Produktet er utviklet for oppbevaring ved en stabil temperatur og kan ikke brukes til å avkjøle eller fryse ned varme/ferske matvarer.

Produktet skal kun brukes til det formålet det er utviklet for. Annen bruk kan føre til at oppbevarte matvarer i produktet ikke holder korrekt temperatur, og det kan dessuten skade produktet.

Produktet er ikke egnet for oppbevaring av blodplasma, laboratorieprøver, legemidler eller liknende stoffer.

Produsenten skal ikke måtte erstatte eller holdes ansvarlig for skader som skyldes uaktsom, feil eller ufornuftig bruk av produktet.

Sikkerhetsinformasjon

Viktig

Beskrivelse av symboler i håndboken.



Advarsel Det kan skje ulykker med personskader hvis disse instruksjonene ikke følges.



Viktig Produktet kan bli skadet eller ødelagt hvis disse instruksjonene ikke følges.

Husk at Hoshizaki har tatt forholdsregler for å ivareta sikkerheten til produktet.

Les nøye gjennom denne informasjonen om sikkerhet.



Det er viktig at alle som skal bruke eller installere produktet, har tilgang til denne håndboken.



Apparatet skal ikke brukes av personer med nedsatte fysiske, sensoriske eller mentale evner eller uten erfaring og kunnskap med mindre de er sammen med eller får vite hvordan apparatet brukes av en person som er ansvarlig for sikkerheten deres.



Barn skal holdes under oppsyn for å sikre at de ikke leker med apparatet.



Apparatet kan ha deler med skarpe kanter i kompressormrommet og innvendig.



Apparatet skal ikke transporteres på en sekkestralle, fordi det kan velte og dermed forårsake personskade.



Ikke dra i selve strø姆ledningen for å trekke ut støpselet eller når du flytter apparatet.

Plassering

Kontroller om emballasjen er skadet når du mottar produktet.

Hvis det er synlige skader på emballasjen, bør det undersøkes om produktet også kan ha blitt skadet. Kontakt forhandleren hvis det er vesentlige skader.



Til denne oppgaven må det være minst 2 personer. Produktet er tyngst helt øverst. Ta hensyn til dette når transportpallen skal fjernes.



Produktet er tungt, og derfor kan det oppstå skader eller riper på gulvet når produktet flyttes.



Korrekt oppsett sikrer en mest mulig effektiv drift.



Produktet skal plasseres i et tørt og tilstrekkelig ventilert rom.



For å sikre effektiv drift skal produktet ikke plasseres i direkte sollys eller mot flater som avgir varme. Produktet kan betjenes når omgivelsestemperaturen ligger på mellom +16 °C og +40 °C.



Produktet skal ikke plasseres i omgivelser med klor/syre (basseng osv.) pga. faren for korrosjon.



Produktet og noen innvendige deler er dekket med beskyttelsesfolie som skal fjernes før bruk.



Rengjør produktet med en mild såpeblanding før bruk.

Installeringsstedet må være horisontalt og i vater.

På utgaver med ben skal bena justeres slik at produktet står oppreist og i vater.

På utgaver med styrehjul skal de to fremste hjulene låses når produktet er plassert der det skal stå

HOSHIZAKI

Premier Remote Cabinets



Det skal alltid være forbeholdt 500 mm til service over produktet. Produktet skal plasseres så nær veggen som mulig.

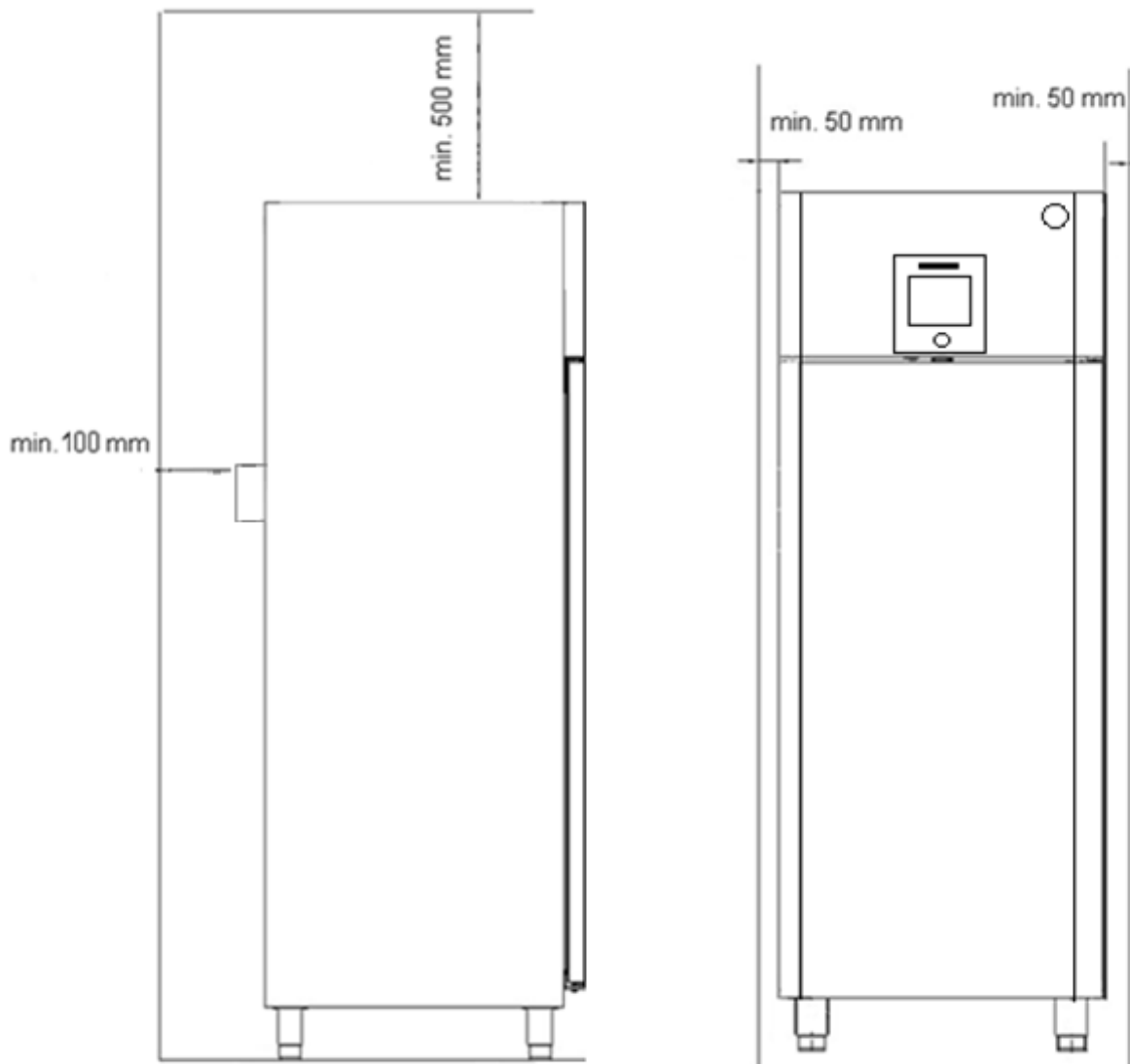

Elektrisk tilkobling

Les nøye gjennom denne teksten før det utføres elektrisk tilkobling.



Produktet skal kobles til vekselstrøm. Spenningen (V) og frekvensen (Hz) for tilkoblingen vises på kjøleskapets merkeplate.



Det må aldri brukes skjøteledning til dette apparatet!

Hvis apparatets strømledning ikke rekker bort til stikkontakten på veggen, kontakter du en elektriker for å få montert en ny stikkontakt til strømledningen.



Hvis det oppstår feil på produktet, **skal det undersøkes av en faglært tekniker** med kjennskap til den installerte kontrollenheten og erfaring i å vedlikeholde CO2-kjøleskapet.

Det skal helst undersøkes av selskapet som tilkoblet produktet.



Strømmen skal alltid være frakoblet hvis det oppstår avbrudd i strømforsyningen, når elektriske deler skal fjernes/monteres og før produktet skal rengjøres og vedlikeholdes.



Produktet skal ikke brukes uten at alle beskyttende deler er montert. Dette er for å unngå kontakt med strømførende eller roterende maskindeler.



Produktet skal ikke brukes utendørs.



Alle krav til jording fra nasjonale myndigheter skal overholdes. Støpselet og stikkontakten må være skikkelig jordet. Kontakt elektriker ved behov.



Kontroller at hovedsikringen er slått av eller at støpselet er trukket ut før det utføres service på elektriske deler. Det holder ikke å slå av produktet på kontrollenheten.

Vanlig bruk



Det er viktig at delene i kjølesystemet ikke skades.



Hvis produktet er utstyrt med et fordamperbrett på undersiden av kjøleskapet, er det viktig at brettet eller varmeelementet ikke vedlikeholdes/rengjøres før kjøleskapet har vært slått av lenge nok til å sikre at fordamperens varmeelement er helt avkjølt, slik at det ikke oppstår brannskader.



Det må ikke brukes elektriske enheter inne i produktet.



De designerte områdene må ikke være i kontakt med matvarer. Dette skal sikre korrekt og effektiv luftstrøm i kjøleskapet.



Alle matvarer må være innpakket eller dekket til før oppbevaring for å unngå unødig korrosjon på kjøleskapets innvendige deler.



Hvis kontrollenhetens standardinnstillinger endres, kan dette føre til at produktet ikke fungerer som det skal og at feil temperaturer kan skade matvarer som oppbevares i produktet.



Maksimal hyllebelastning er 40 kg.



Det må ikke oppbevares eksplosive stoffer som spraybokser med brennbar drivgass i dette apparatet.



Det må ikke plasseres matvarer under den nederste hyllestøtten eller over det øverste merket.

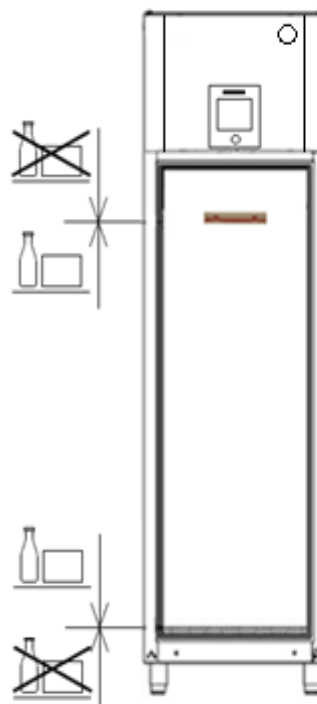

Do not store goods above the top loading mark

Do not store goods below the bottom grate

Betjene produktet (Evco-kontrollenhet – RU1-modell)

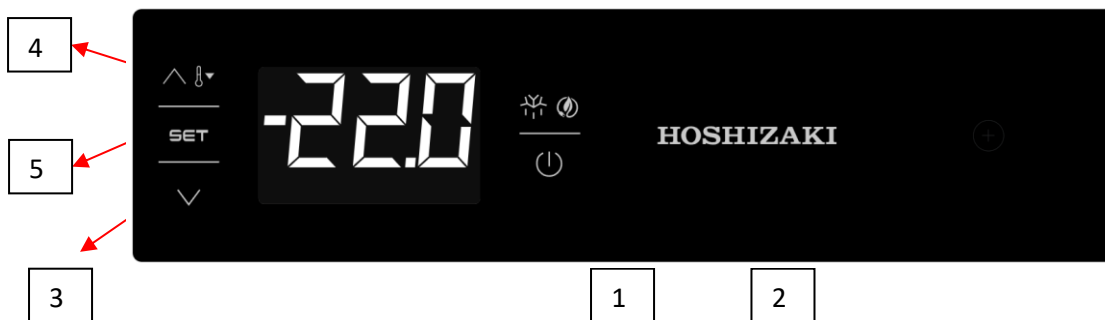

➤ FUNKSJONER PÅ FRONTPANELET

Tastene på frontpanelet låses ved å holde inne AUX (3) og On/Stand By (1) i 2 sekunder. Teksten «Loc» vises på skjermen når tastene er låst, og de er ikke låst når teksten «UnL» vises.

1) Når du holder inne **PÅ/STANDBY** i 4 sekunder, åpnes og lukkes apparatet (på/av).

2) **MANUELL AVRIMING**-tasten: Manuell avriming starter når du holder inne knappen i 4 sekunder. Manuell avriming starter ikke hvis ekstra kjøling er aktivert og temperaturen i fordampere ikke er egnet.

3) **NED**-tasten: Bla nedover i menyen eller senk verdien. Hvis du holder inne knappen i 4 sekunder, aktiveres ekstra kjøling. Den angitte temperaturen kan ikke senkes når funksjonen for ekstra kjøling er aktivert. Tiden og temperaturen fastsettes ved hjelp av verdiene. Apparatet vil ikke avises så lenge funksjonen for ekstra kjøling er aktivert.

4) **OPP**-tasten: Bla oppover i menyen eller øk verdien. Holder du inne knappen i 4 sekunder, får du tilgang til prosentandelen til funksjonen for lav og høy relativ luftfuktighet. (På noen modeller) står det «rhL» på skjermen (det brukes en lav prosentandel i funksjonen for relativ luftfuktighet) eller det står «rhH» på skjermen (det brukes en høy prosentandel i funksjonen for relativ luftfuktighet). Disse funksjonene vises på skjermen i 10 sekunder. Hvis kontrollen for luftfuktighet ikke er tilgjengelig, vises «----» på skjermen i 1 sekund.

5) **SET**-tasten: Angi og endre tast for justerbare verdier.

➤ DRIFT

Ulike driftsstatus vises nedenfor:

«**På**»-status: Støpselet står i og apparatet er slått på.

«**Standby**»-status: Støpselet står i, men apparatet er slått av.

«**Av**»-status: Trekk ut støpselet eller slå av hovedsikringen hvis du vil slå av apparatet.

Betjene produktet (Danfoss-kontrollenhet – AK-CC55)

Oppstart:

Sett i støpselet.

Kontroller at den 2-polede hovedbryteren er slått på.

Oversikt over displayet (AK-UI55):

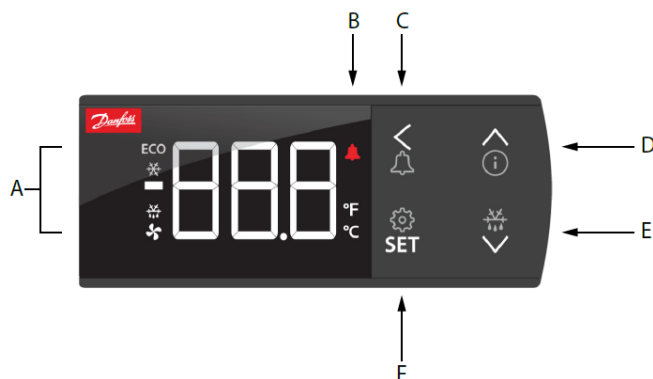

Områder på displayet	Beskrivelse
A	Lyser ved:  <ul style="list-style-type: none"> – Energioptimalisering (ECO) – Kjøling – Avriming – Bruk av vifte
B	Lyser ved alarm.
C	Hold alarmknappen inne (i 3 sekunder) (reléet tilbakestilles) for å vise alarmkoden.
D	Hold knappen inne (i 3 sekunder) for å åpne informasjonsmenyen «InF». (Se figur «b».) Pil opp/ned/venstre: Brukes til navigering i menyen og innstilling av verdier.
E	Hold knappen inne (i 3 sekunder) for å starte avriming, «-d-» vises på displayet. Pågående avriming kan stanses ved å holde knappen inne.
F	SET: Hold knappen inne (i 3 sekunder) for å åpne «SET»-menyen. Hvis driften er låst med et passord, vises «PS» på displayet. Skriv inn koden. * Viser innstillingen for en valgt verdi / lagrer en endret innstilling. Trykk på knappen for å angi termostatens grenseverdier for utkobling.

* Standardinnstillingen for P89 er «0», og det er ikke nødvendig å angi noen verdier.

HOSHIZAKI

Premier Remote Cabinets



a – Innstillinger for «SET»-knappen

b – Innstillinger for «Info»-knappen

SET	←	SET button, 3 s: Configuration settings
Set		
(PS) v	←	PS: Password (if any)
cFg	SET →	
v		
r--		
A--		
c--		
d--		
n--		
F--		
t--		
h--		
o--		
p--		
q--		
u--		
<		
(Return)		

Menu groups
See also the following pages.

r12	Main switch
o61	Application
o03	MODBUS address
r89	Food type
r00	Cut-out temperature
r15	Ther. sensor S4 %
r61	Ther. sensor S4% night
A36	Alarm sensor S4%
o17	Display air S4%
o30	Refrigerant type
o20	Min. transmitter range
o21	Max. transmitter range
d01	Defrost method
d03	Defrost interval
d10	Defrost sensor
d04	Max. defrost time
d02	Defrost stop temperature
<	
(Return)	

^	←	Info button, 3 s: Information for service use
Inf		
StA	SET	See control state message
App	SET	See selected application
in	SET →	
out	SET →	
buS	SET	MODBUS quality
SoF	SET	See SW version
<		
(Return)		

do1	*	Read output status
do2	*	
do3	*	
do4	*	
Ao1	**	
<		(Return)

Al1	(PE)	Read input status
Al2	**	
Al3	**	
Al4	**	
Al5	**	
di1	**	
di2	**	
<		(Return)

Output status
When you want info on a relay output, the dot will show whether the relay is activated (energized)
for e.g.:
do4 = not activated
do.4 = activated

Feilmeldinger (alarmer)



Hvis det oppstår en feil på produktet, vil alarmlampen foran lyse og alarmreléet vil aktiveres (avhengig av prioritet). Hvis du holder inne alarmknappen i 3 sekunder, vises alarmkoden på displayet.

Les mer i håndboken for valgt CO₂-kontrollenhet. (Danfoss AK-CC55 Compact)

Code	Alarm text	Description
E01	Hardware failure	The controller has a hardware failure
E06	Clock lost time	Clock has lost valid time
E20	Pe Evap. pressure A - Sensor error	Sensor signal is out of range. Please check the sensor for correct operation
E24	S2 Gas outlet A - Sensor error	Sensor signal is out of range. Please check the sensor for correct operation
E25	S3 Air ON evap. A - Sensor error	Sensor signal is out of range. Please check the sensor for correct operation
E26	S4 Air OFF evap. A - Sensor error	Sensor signal is out of range. Please check the sensor for correct operation
E27	S5 Evaporator A - Sensor error	Sensor signal is out of range. Please check the sensor for correct operation
A01	High temperature alarm A	The alarm temperature has been above the max alarm limit for a longer time period than the set alarm delay.
A02	Low temperature alarm A	The alarm temperature has been below the min alarm limit for a longer time period than the set alarm delay.
A04	Door open alarm	The door has been open for a too long time
A05	Max defrost hold time exceeded	The controller has been waiting longer time than permitted after a co-ordinated defrost.
A11	Refrigerant not selected	The refrigerant has not been selected hence control can not be initiated
A15	DI alarm 1	Alarm signal from digital input signal
A16	DI alarm 2	Alarm signal from digital input signal
A45	Main switch set OFF	The controller main switch has been set to either Stop or Manual control. Alternatively a digital input set up for "main switch" function, has stopped control
A59	Case in cleaning mode	A case cleaning operation has been started on a case
AA2	CO ₂ leak detected	CO ₂ is leaking from the refrigeration system
AA3	Refrigerant leak detected	Refrigerant is leaking from the refrigeration system
a04	Wrong IO configuration	Inputs and outputs have not been configured correctly

Betjene produktet (Carel MPXpro-kontrollenhet)

Oppstart

Sette i støpselet

Kjøleskapets kontrollenhet er som standard slått på ved levering. Det betyr at kontrollenheten vil starte når støpselet settes i og hovedbryteren er slått på.

Slå kjøleskapet på/av

Du slår kjøleskapet på/av med den 2-polede hovedbryteren. Du finner den i «kompressorrommet» til venstre i boksen med hovedbrytere.

Displayet





Oversikt/beskrivelse av displayet:



Displayet ovenfor har en tresifret visning.

Det finnes ulike lamper på displayet. Disse lampene gir følgende angivelser.

Generelt = Når lampen blinker, vil aktiveringen være forsinket eller begrenset.

-  = Kjøling er på (kjøling er på når LED-lampen lyser).
-  = Den innvendige viften går (innvendig/fordamperens vifte går når LED-lampen lyser).
-  = Avriming er på (avriming pågår når LED-lampen lyser).
-  = Hvis LED-lampen blinker, betyr det at døren står åpen eller at det er utløst en alarm eller feil.

HACCP = Det er utløst en HACCP-alarm når LED-lampen lyser. Det er registrert en HACCP-alarm når LED-lampen blinker.

Knapper:

De 4 knappene til høyre på displayet brukes til å få tilgang til og angi ulike verdier. Disse knappene kan brukes enkeltvis eller i ulike kombinasjoner for å betjene kontrollenheten.

Innstillingene nedenfor er de eneste som skal kunne endres av sluttbrukeren. Sluttbrukeren skal ikke endre verdier som ikke er beskrevet her. Alle andre innstillinger skal utføres av en faglært tekniker.

BRUKERINNSTILLINGER

Justere kjøleskapets innstillingsverdi for temperatur



- Hold inne Set-knappen ved vanlig drift helt til displayet begynner å blinke. Kjøleskapets innstillingsverdi for temperatur kan justeres med Pil opp og Pil ned.
- Når innstillingsverdien er justert til ønsket temperatur, trykker du raskt på Set-knappen for å lagre den nye verdien og gå tilbake til vanlig drift.

Slik utfører du manuell avriming

- Hold inne def-knappen i minst 5 sekunder ved vanlig drift for å utføre en manuell avriming, forutsatt at fordamperens føler er kald nok.
- Når avrimingssymbolet  lyser, betyr dette at avriming pågår.
- Hvis def-knappen holdes inne i mer enn 5 sekunder mens avriming pågår, vil avrimingen deaktiveres.

Slik demper du lydsignaler

- Du vil høre et lydsignal når kontrollenheten er i alarmmodus. Alarmsignalet dempes når du trykker på Prg/mute-knappen.

Angi alarmens grenseverdier for temperatur

- Hold inne Prg/mute-knappen i minst 5 sekunder ved vanlig drift for å åpne oversikten over verdier. Displayet viser **/c1**.

HOSHIZAKI

Premier Remote Cabinets



- Trykk på Prg/mute-knappen . Den første kategorien med verdier, «Pro», vises.
- Trykk på Pil opp helt til du kommer til kategorien «ALn», som angis ved at -ikonet lyser på displayet.
- Trykk på Set-knappen . Verdien AA vises.
- Trykk på Pil opp til du kommer til A1.
- Trykk på Set-knappen for å justere om AL-innstillingene (terskelverdi for **Alarm Lav** temperatur) og AH-innstillingene (terskelverdi for **Alarm Høy** temperatur) skal være (0 = gjelder innstillingsverdier for kjøleskapets temperatur) eller (1 = absolutt) standard innstilling = 1.
- Trykk på Set-knappen for å lagre valgt innstilling og gå tilbake til A1.
- Trykk på Pil opp helt til du kommer til AL (terskelverdi for **Alarm Lav** temperatur).
- Trykk på Set-knappen for å kunne justere AL ved hjelp av Pil opp og Pil ned (kan justeres mellom -50 og +50). Standard innstilling = -50 °C.
- Trykk på Set-knappen for å lagre valgt innstilling og gå tilbake til AL.
- Trykk på Pil opp helt til du kommer til AH (terskelverdi for **Alarm Høy** temperatur).
- Trykk på Set-knappen for å kunne justere AH ved hjelp av Pil opp og Pil ned (kan justeres mellom -50 og +50). Standard innstilling = +50 °C.
- Trykk på Set-knappen for å lagre valgt innstilling og gå tilbake til AH.
- Trykk på Pil opp helt til du kommer til Ad (**Alarm Delay** (utsatt) tid for AL og AH).
- Trykk på Set-knappen for å kunne justere Ad ved hjelp av Pil opp og Pil ned (kan justeres mellom 0 og 240 minutter). Standard innstilling = 120 minutter.
- Trykk på Set-knappen for å lagre valgt innstilling og gå tilbake til Ad.
- Hold inne Prg/mute-knappen i minst 5 sekunder for å lagre endringene og gå tilbake til hovedmenyen.

Hvis du skal angi alarmens terskelverdier for temperatur og utsatt alarmtid for kjøleskap eller fryser, anbefales alarminnstillingene nedenfor:

	Innstillingsverdi	A1	AL	AH	Ad
Kjøleskap	+5 °C	1	+1 °C	+8 °C	120 min
Fryser	-18 °C	1	-50 °C	-15 °C	120 min



Slik viser du alarmhistorikken

- Hold inne Prg/mute-knappen og Set-knappen i 5 sekunder.
- Skriv inn passordet 44.
- Trykk på Set-knappen for å åpne en undermeny der du kan bruke Pil opp og Pil ned til å finne ulike alarmer, fra HS0 til HS9.

- Velg en alarm, og trykk på Set-knappen for å vise kode, time, minutter og varighet.
- I undermenyen trykker du på Prg/mute-knappen for å gå tilbake til den overordnede verdien «HSx».

- Hold inne Prg/mute-knappen i 5 sekunder for å gå tilbake til vanlig

display. Eksempel:

'HI' -> 'h17' -> 'm23' -> '65'

viser at alarm 'HI' (alarm for høy temperatur) ble aktivert kl. 17:23 og pågikk i 65 minutter.

HACCP-ALARMER

Det er to typer HACCP-hendelser som behandles:

- Typen HA-alarmer, med høy temperatur under drift.
- Typen HF-alarmer, med høy temperatur etter strømbrudd (driftsstans).

Når det registreres en alarm, vil HACCP-lampen blinke, alarmkoden vises på displayet, alarmen lagres og alarmreléet og alarmsignalet utløses.

Slik viser du HA- og HF-alarmer

- Trykk samtidig på Prg/mute-knappen og Pil ned .

- Se gjennom oversikten over alarmer ved å trykke på Pil opp og Pil ned .

- Trykk på Set-knappen for å velge alarmen.
- Trykk på Pil opp eller Pil ned for å se en beskrivelse med år, måned, dag, time, minutter og varighet for valgt alarm.

- Trykk på Prg/mute-knappen igjen for å gå tilbake til forrige oversikt.

På HACCP-alarmmenyen kan du dessuten gjøre følgende:



Slik sletter du en HACCP-alarm

- Hold inne Set-knappen og Pil ned i 5 sekunder når oversikten over alarmer vises.

Dermed vil HACCP begynne å blinke, displayet viser meldingen rES og overvåkingen av HACCP-alarmer startes på nytt.

Slik sletter du hele minnet med HACCP-alarmer

- Hold inne Set-knappen og Pil opp og Pil ned i 5 sekunder.

Dermed vises meldingen rES, hele minnet med alarmer slettes og overvåkingen startes på nytt for HACCP-alarmer.

Sanntidsklokken må være stilt av montøren før kjøleskapet ble overlevert til sluttbrukeren for at du skal kunne bruke HACCP-alarmene. Disse justeringene er beskyttet med en tilgangskode og kan derfor ikke foretas av sluttbrukeren.

Kjøleskapets lampe

På alle modeller er lampen plassert på utsiden av kjøleskapet, over døren. Lampen betjenes med hovedkontrollenheten, så funksjonen kan altså ikke endres.

Når kjøleskapsdøren åpnes, tennes lampen over døren. Når kjøleskapsdøren lukkes, slukkes lampen over døren.

HOSHIZAKI

Premier Remote Cabinets



Feil og alarmer

Display code	Cause of the alarm	Icon flash on display	Alarm relay	Buzzer	Reset	Compressor	Defrost	Evaporator fans	Continuous cycle	Signalled on tLAN	Network solenoid valve
rE	Control probe fault		ON	ON	automatic	duty setting(c4)	unchanged	unchanged	unchanged	√	-
E1	Probe S1 fault		OFF	OFF	automatic	duty setting(c4)	unchanged	unchanged	unchanged	√	-
E2	Probe S2 fault		OFF	OFF	automatic	unchanged	unchanged	unchanged	unchanged	√	-
E3	Probe S3 fault		OFF	OFF	automatic	unchanged	unchanged	unchanged	unchanged	√	-
E4	Probe S4 fault		OFF	OFF	automatic	unchanged	unchanged	unchanged	unchanged	√	-
E5	Probe S5 fault		OFF	OFF	automatic	unchanged	unchanged	unchanged	unchanged	√	-
E6	Probe S6 fault		OFF	OFF	automatic	unchanged	unchanged	unchanged	unchanged	√	-
E7	Probe S7 fault		OFF	OFF	automatic	unchanged	unchanged	unchanged	unchanged	√	-
E8	Serial probe S8 not updated		OFF	OFF	automatic	duty setting(c4)	unchanged	unchanged	unchanged	√	-
E9	Serial probe S9 not updated		OFF	OFF	automatic	duty setting(c4)	unchanged	unchanged	unchanged	√	-
E10	Serial probe S10 not updated		OFF	OFF	automatic	duty setting(c4)	unchanged	unchanged	unchanged	√	-
E11	Serial probe S11 not updated		OFF	OFF	automatic	duty setting(c4)	unchanged	unchanged	unchanged	√	-
LO	Low temperature alarm		ON	ON	automatic	unchanged	unchanged	unchanged	unchanged	√	-
HI	High temperature alarm		ON	ON	automatic	unchanged	unchanged	unchanged	unchanged	√	-
LO2	Low temperature alarm		ON	ON	automatic	unchanged	unchanged	unchanged	unchanged	√	-
HI2	High temperature alarm		ON	ON	automatic	unchanged	unchanged	unchanged	unchanged	√	-
IA	Immediate alarm from external contact		ON	ON	automatic	duty setting(A6)	unchanged	unchanged	unchanged	√	-
dA	Delayed alarm from external contact		ON	ON	automatic	duty setting(A6) if A7≠0	unchanged	unchanged	unchanged	√	-
dor	Door open for too long alarm		ON	ON	automatic	unchanged	unchanged	unchanged	unchanged	√	-
Etc	Real time clock fault		OFF	OFF	automatic	unchanged	unchanged	unchanged	unchanged	√	-
LSH	Low superheat alarm		OFF	OFF	automatic	OFF	unchanged	unchanged	unchanged	√	√
LSA	Low suction temperature alarm		OFF	OFF	automatic / manual	OFF (paragraph 6.10)	unchanged	unchanged	unchanged	√	√
MOP	Maximum evaporation pressure alarm		OFF	OFF	automatic	OFF	unchanged	unchanged	unchanged	√	√
LOP	Low evaporation temperature alarm		OFF	OFF	automatic	unchanged	unchanged	unchanged	unchanged	√	√
bLo	Valve blocked alarm		OFF	OFF	manual/ disabled with P14=0	unchanged	unchanged	unchanged	unchanged	√	-
Edc	Communication error with stepper driver		ON	ON	automatic	unchanged	unchanged	unchanged	unchanged	√	-
EFS	Stepper motor broken/not connected		ON	ON	automatic	unchanged	unchanged	unchanged	unchanged	√	-
EE	Flash unit parameter error		OFF	OFF	automatic	OFF	not performed	OFF	not performed	√	-
EF	EEPROM operating parameter error		OFF	OFF	automatic	OFF	not performed	OFF	not performed	√	-
HA	Type HA HACCP alarm	HACCP	OFF	OFF	manual	unchanged	unchanged	unchanged	unchanged	√	-
HF	Type HF HACCP alarm	HACCP	OFF	OFF	manual	unchanged	unchanged	unchanged	unchanged	√	-
MA	Communication error with Master (only on Slave)		ON	ON	automatic	unchanged	unchanged	unchanged	unchanged	-	-
u1...u5	Communication error with Slave (only on Master)		ON	ON	automatic	unchanged	unchanged	unchanged	unchanged	-	-
n1...n5	Alarm on unit 1 to 5 in the network		ON	ON	automatic	unchanged	unchanged	unchanged	unchanged	-	-
up1...up5	Upload procedure with errors on unit 1 to 5		OFF	OFF	-	unchanged	unchanged	unchanged	unchanged	-	-
GPE	Error in custom gas parameters		ON	ON	automatic	OFF	not performed	OFF	not performed	√	-



Les mer i håndboken for valgt CO2-kontrollenhet. (Carel MPXpro)



Betjene produktet (uten kontrollenhet – NC-modell)



Se håndboken for den installerte kontrollenheten.

Feilsøking

Støy:

- Be om service hvis det oppstår unormal støy.
- Driftslyder fra den innvendige viften er normalt.
- Hvis det høres støy fra deler på metallplater, frontpaneler eller paneler på forsiden, kan disse delene være åpne. Lukk panelene.

Rim innvendig:

- For høy luftfuktighet.
- Døren åpnes for ofte.
- Døren blir stående åpen for lenge.
- Ødelagt dørpakning. Bør undersøkes nøye og se etter skader.

Svak kjøleeffekt:

- For høy omgivelsestemperatur.
- Døren åpnes for ofte og/eller blir stående åpen for lenge.
- Døren er blitt stående åpen.
- Ødelagt dørpakning.
- For høy temperaturinnstilling.
- Produktet er fylt med for mange matvarer – blokkert luftinntak/-utløp.
- Det er lagt romtempererte eller varme matvarer i produktet.
- Avriming pågår. Kjøleskapets temperatur kan stige midlertidig under avriming, men dette vil ikke påvirke matvarene. Avrimingslampen lyser.

Enkelte matvarer er frosne:

- Produktet er fylt med for mange matvarer – blokkert luftinntak/-utløp.
- For lav innstillingsverdi for temperatur.
- Fordamperens vifte kan være defekt.

Kondens rundt kjøleskapsdøren:

- For høy luftfuktighet.
- Døren ble ikke skikkelig lukket.
- Ødelagt dørpakning.
- Verdien for dørkarmens varmeelement er ikke justert korrekt.

For høyt energiforbruk:

- For høy omgivelsestemperatur.
- Døren åpnes for ofte og/eller blir stående åpen for lenge.
- Døren er blitt stående åpen.
- Ødelagt dørpakning.
- For lav innstillingsverdi for temperatur.
- Produktet er fylt med for mange matvarer – blokkert luftinntak/-utløp.
- Det er lagt romtempererte eller varme matvarer i produktet.
- Produktet står i direkte sollys eller for nær flater som avgir varme.
- Standardinnstillingene er blitt endret.



Vann ved avriming

Under avrimingen vil kjøleskapet avgi vann som ledes til fordampersystemet gjennom et lufttomt plastrom øverst på kjøleskapet (gjelder Premier-kjøleskap).

Vannet fordampes på nytt med et elektrisk varmeelement og en viftemotor. I sjeldne tilfeller kan bruken av kjøleskapet føre til at det dannes mer vann enn kjøleskapet klarer å fordampe, og dermed kan vannet flomme over. I så fall kan det varmeelementet justeres slik at det kjøres med 100 %, eller det kan kobles fra og vannrøret bak kan i stedet kobles til et avløp. Disse endringene må utføres av en faglært tekniker.

Dørens lukkemekanisme

Døren er utstyrt med et selvlukkende system. Hvis døren åpnes mindre enn 90°, vil den lukkes automatisk. Hvis døren åpnes mer enn 90°, vil den bli stående åpen.

Døren kan åpnes med fotpedalen. Dermed vil du ha begge hendene frie når du plasserer matvarer i kjøleskapet.

Strømbrudd

Ved strømbrudd vil kontrollenheten huske temperaturinnstillingen og starte produktet på nytt når strømmen er tilbake.

Rengjøring

Utilstrekkelig rengjøring vil føre til at produktet ikke fungerer med optimal ytelse eller det kan bli defekt.



Støpselet skal alltid trekkes ut før produktet rengjøres.



Du må ikke spyle produktet med vann og heller ikke bruke vannstråle eller vanndamp, for dette kan føre til kortslutning i det elektriske anlegget.



Rengjøringsmidler som inneholder klor eller klorblandinger i tillegg til andre etsende midler **skal ikke brukes**, fordi de kan forårsake korrosjon på de rustfrie panelene til kjøleskapet og fordamperen.



Produktet må holdes rent for støv og smuss. Dette gjøres best med en støvsuger og støvkost.



Til det utvendige vedlikeholdet skal det brukes poleringsmiddel til rustfritt stål.



Produktet skal jevnlig rengjøres innvendig med en mild såpeblanding og kontrolleres grundig før det tas i bruk igjen.

HOSHIZAKI

Premier Remote Cabinets



Dørpakninger

I dette avsnittet forklarer vi hvorfor dørpakningen må være i god stand.

Pakninger utgjør en viktig del av kjøleskapet/fryseren. Hvis pakningen ikke fungerer optimalt, vil ikke kjøleskapet kunne lukkes skikkelig. Dette kan føre til økt luftfuktighet, rim på innsiden, rim på fordampere (gir til dårligere kjølekapasitet) og i verste fall redusert levetid for kjøleskapet.



Derfor er det viktig å passe på at pakningen er i god stand. Vi anbefaler at den undersøkes jevnlig.

Pakningen skal rengjøres regelmessig med mildt såpevann. Kontakt

forhandleren hvis pakningen må skiftes.

Lagring i lang tid

Hvis produktet skal tas ut av drift og klargjøres for lagring i lang tid, må du rengjøre innsiden, døren og dørpakningen grundig med en klut fuktet i varmt såpevann. Eventuelle matrester kan forårsake mugg.

Service

Hvis kjøleskapet ikke fungerer, bør du først undersøke om hovedbryteren er blitt slått av eller støpselet trukket ut, eller om sikringen er gått.

Kontakt forhandleren hvis du ikke finner årsaken til hvorfor kjøleskapet ikke virker lenger.

Oppgi kjøleskapets modellnavn og serienummer når du kontakter HOSHIZAKI eller montøren. Du finner denne informasjonen på merkeplaten.









HOSHIZAKI

Premier Remote Cabinets



Tekniske data

Etikettens plassering:

PRODUCT DESCRIPTION LABEL																														
1 Product Number		<table border="1" style="width: 100%; border-collapse: collapse;"> <tr> <td style="width: 70%;">PRODUCT NUMBER</td> <td style="width: 30%; text-align: center;">1</td> </tr> <tr> <td colspan="2" style="text-align: center;">  </td> </tr> <tr> <td>PRODUCT DESCRIPTION</td> <td style="text-align: center;">2</td> </tr> <tr> <td>MODEL</td> <td style="text-align: center;">3</td> </tr> <tr> <td>REFRIGERANT</td> <td style="text-align: center;">4</td> </tr> <tr> <td>CO2 EQUIVALENT</td> <td style="text-align: center;">5</td> </tr> <tr> <td>IP PROTECTION</td> <td style="text-align: center;">6</td> </tr> <tr> <td>CLIMATE CLASS</td> <td style="text-align: center;">7</td> </tr> <tr> <td>PRODUCTION DATE</td> <td style="text-align: center;">8</td> </tr> <tr> <td>TOTAL POWER / CURRENT / LAMP POWER</td> <td style="text-align: center;">9</td> </tr> <tr> <td>VOLTAGE - FREQUENCY</td> <td style="text-align: center;">10</td> </tr> <tr> <td>HEATING ELEMENT</td> <td style="text-align: center;">11</td> </tr> <tr> <td>SYSTEM PRESSURE</td> <td style="text-align: center;">12</td> </tr> <tr> <td>BLOWING AGENT</td> <td style="text-align: center;">13</td> </tr> </table>	PRODUCT NUMBER	1			PRODUCT DESCRIPTION	2	MODEL	3	REFRIGERANT	4	CO2 EQUIVALENT	5	IP PROTECTION	6	CLIMATE CLASS	7	PRODUCTION DATE	8	TOTAL POWER / CURRENT / LAMP POWER	9	VOLTAGE - FREQUENCY	10	HEATING ELEMENT	11	SYSTEM PRESSURE	12	BLOWING AGENT	13
PRODUCT NUMBER		1																												
																														
PRODUCT DESCRIPTION		2																												
MODEL		3																												
REFRIGERANT		4																												
CO2 EQUIVALENT		5																												
IP PROTECTION		6																												
CLIMATE CLASS		7																												
PRODUCTION DATE		8																												
TOTAL POWER / CURRENT / LAMP POWER		9																												
VOLTAGE - FREQUENCY		10																												
HEATING ELEMENT		11																												
SYSTEM PRESSURE		12																												
BLOWING AGENT	13																													
2 Product Description																														
3 Model																														
4 Refrigerant (GWP)																														
5 CO2 Equivalent																														
6 IP Protection																														
7 Climate Class																														
8 Production Date																														
9 Total power / Current / Lamp power																														
10 Voltage - Frequency																														
11 Heating Element																														
12 System Pressure																														
13 Blowing Agent																														
14 Serial Number		<p>S/N: 14</p>  <p>HOSHIZAKI EUROPE B.V. Burgemeester Stramanweg 101 1101 AA Amsterdam, The Netherlands</p> <div style="display: flex; justify-content: space-around; align-items: center;">    </div>																												

Trade mark			HOSHIZAKI			
Tiltenkt bruk			PREMIER U 70	PREMIER U 140	PREMIER U 80	PREMIER U 60
Kjøletemperatur			Storage	Storage	Storage	Storage
Frysetemperatur			X	X	X	X
Flerbruksskap			X	X	X	X
Vertikalt skap						
Benkeskap			X	X	X	X
Verdi						
Parameter	Symbol	Unit				
Bruttovolum	VnT	L	700	1400	700	480
Klimaklasse			CC5	CC5	CC5	CC5
Spenning/frekvens	V / Hz		230 - 50	230 - 50	230 - 50	230 - 50
Kjølemiddel (CO2-kjøleskap)			CO2	CO2	CO2	CO2
Kjølemiddel (RU-1-kjøleskap)			HFC / HFO Refrigerant*	HFC / HFO Refrigerant*	HFC / HFO Refrigerant*	HFC / HFO Refrigerant*
Kontaktinformasjon:	<p>HOSHIZAKI EUROPE B.V. Address: Burgemeester Stramanweg 101 1101 AA Amsterdam, The Netherlands Tel: +31 (0)20 691 84 99 - http://hoshizaki.europe.com/</p>					

* Kjølemidler som er kompatible med strupeorgan (R449A, R448A, R45A osv. – se datablad ved bruk av strupeorgan)

HOSHIZAKI

Premier Remote Cabinets



Trade mark			HOSHIZAKI		
Model name			BAKER U 950	BAKER GA 950	PREMIER SF 950
Avsedd användning			Storage	Cooling /Freezing / Storage / Proving	Cooling / Shock Freezing
Kjøletemperatur			X	X	X
Frysetemperatur			X	X	X
Flerbruksskap				X	X
Vertikalt skap			X	X	X
Benkeskap					
Parameter	Symbol	Unit			
Bruttovolum	VnT	L	1000	950	950
Klimaklasse			CC5	CC5	CC5
Spenning/frekvens	V / Hz		230 - 50	230 – 50	230 – 50
Kjølemiddel (RU-1-kjøleskap)			HFC / HFO Refrigerant*	HFC / HFO Refrigerant*	HFC / HFO Refrigerant*
Kontaktinformasjon		HOSHIZAKI EUROPE B.V.			
		Address: Burgemeester Stramanweg 101 1101 AA Amsterdam, The Netherlands Tel: +31 (0)20 691 84 99 - http://hoshizaki.europe.com/			

* Kjølemidler som er kompatible med strupeorgan (R449A, R448A, R45A osv. – se datablad ved bruk av strupeorgan)

HOSHIZAKI

Premier Remote Cabinets



Mål

PREMIER U 70

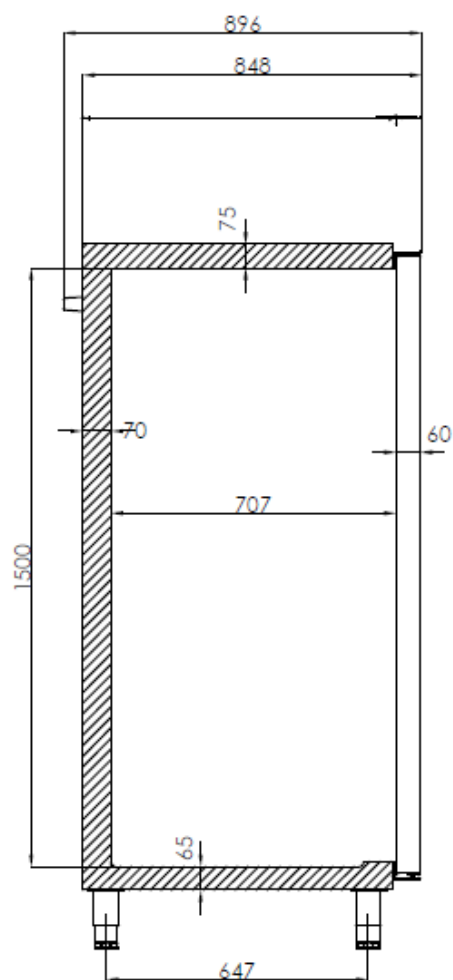
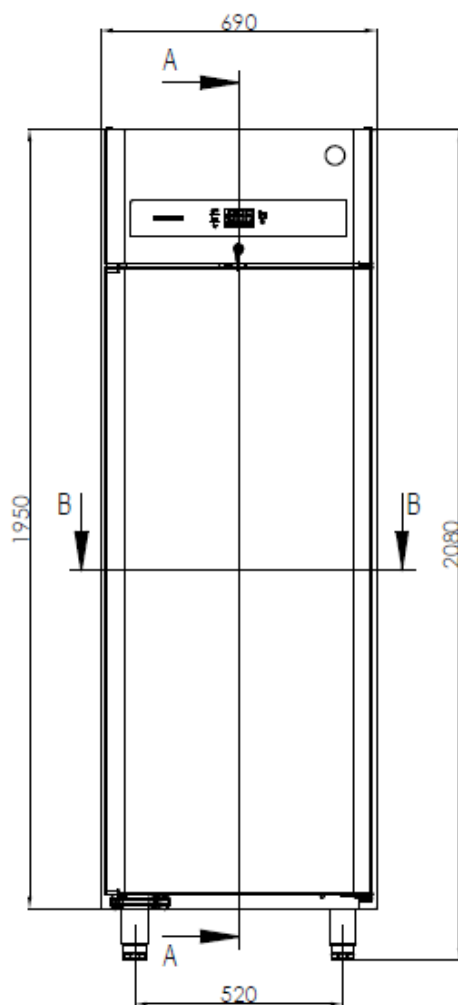

A-A

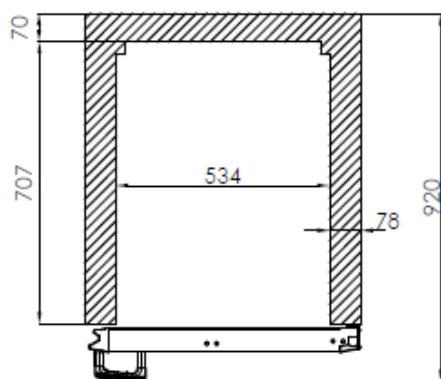

B-B

HOSHIZAKI

Premier Remote Cabinets



PREMIER U 60

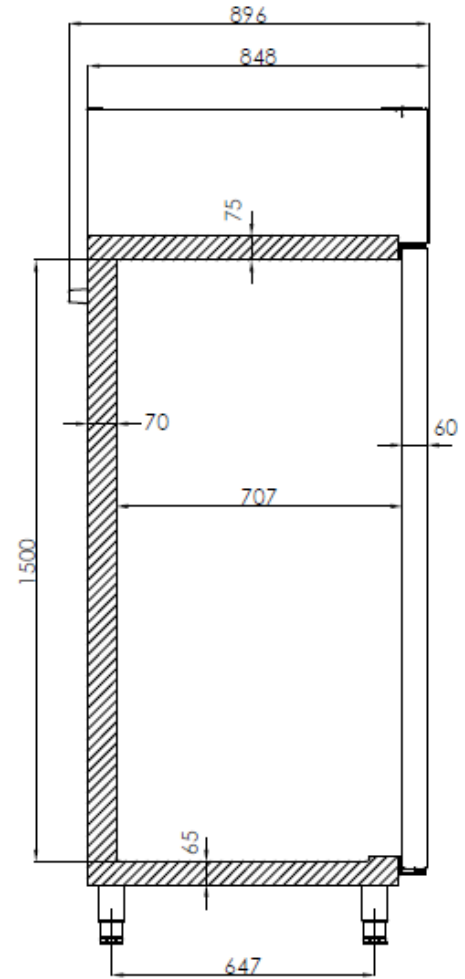
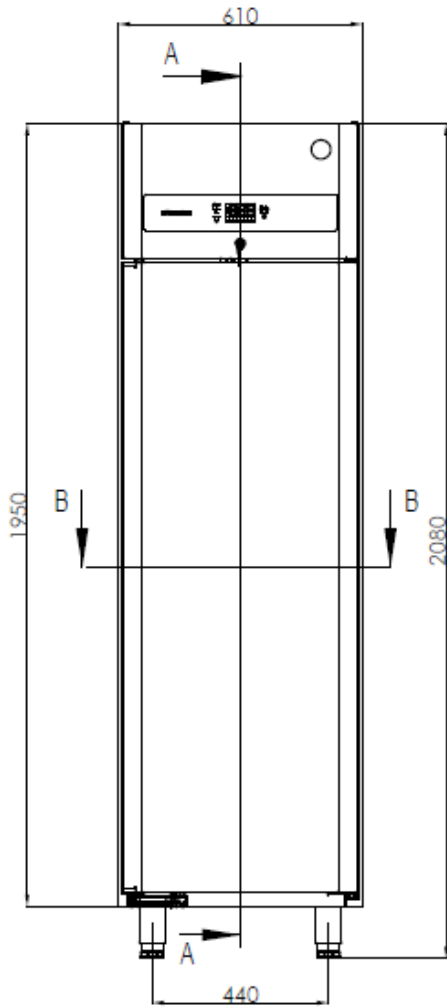

A-A

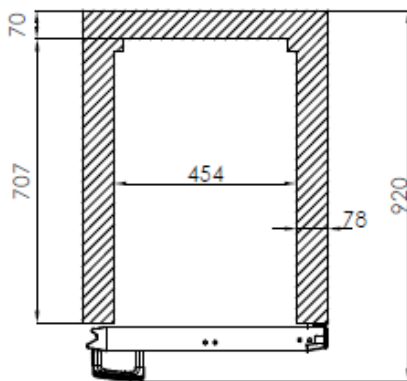

B-B

HOSHIZAKI

Premier Remote Cabinets



PREMIER U 80

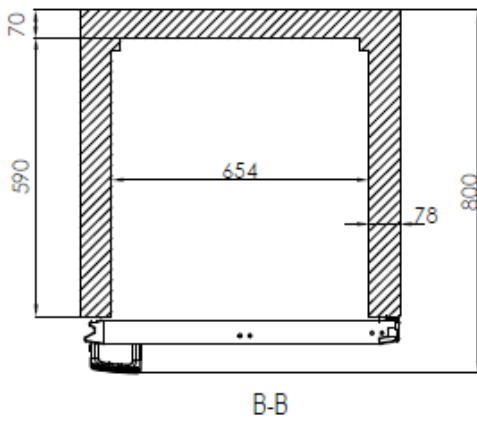
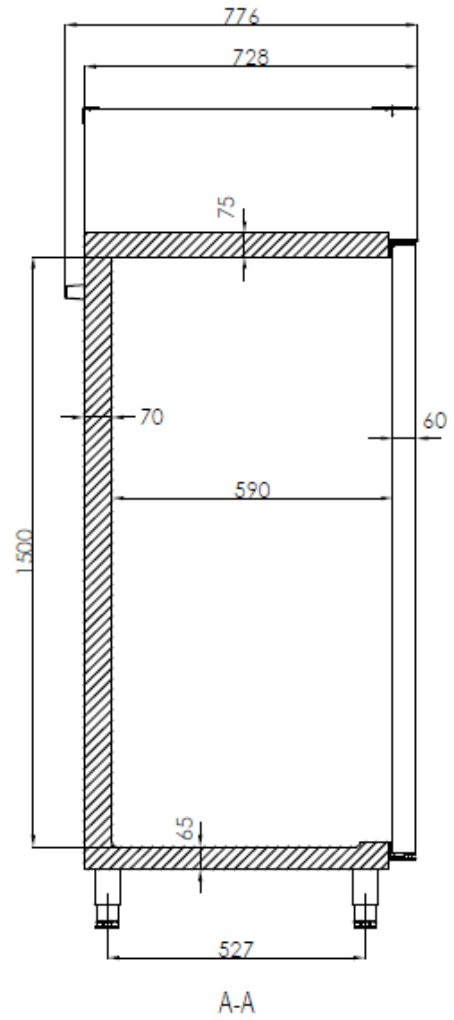
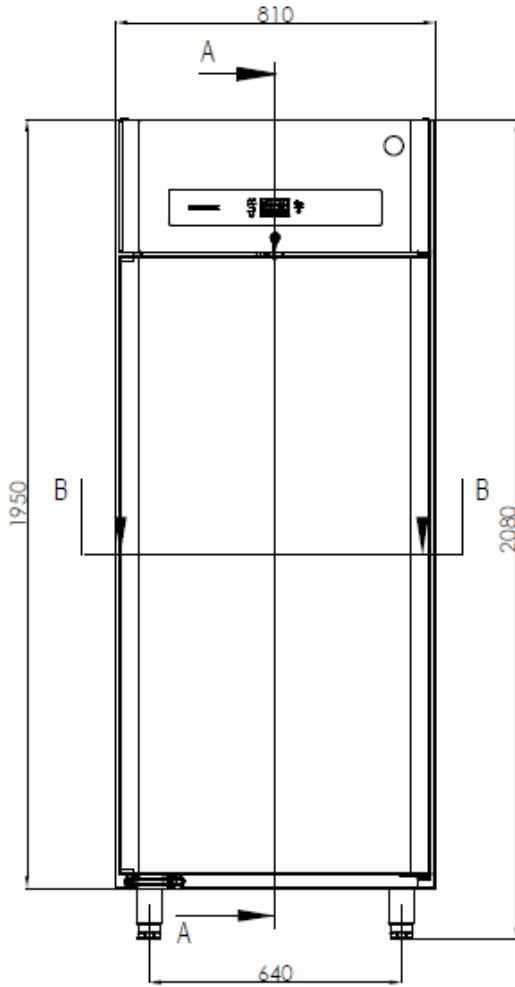

HOSHIZAKI

Premier Remote Cabinets



PREMIER U 140

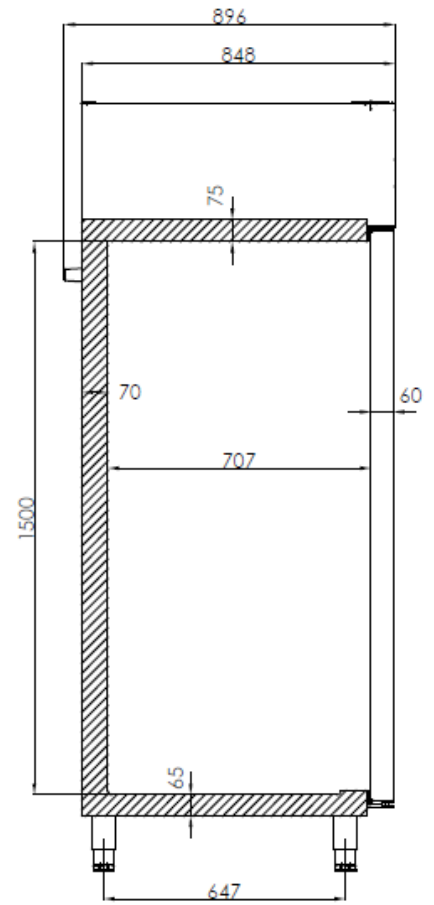
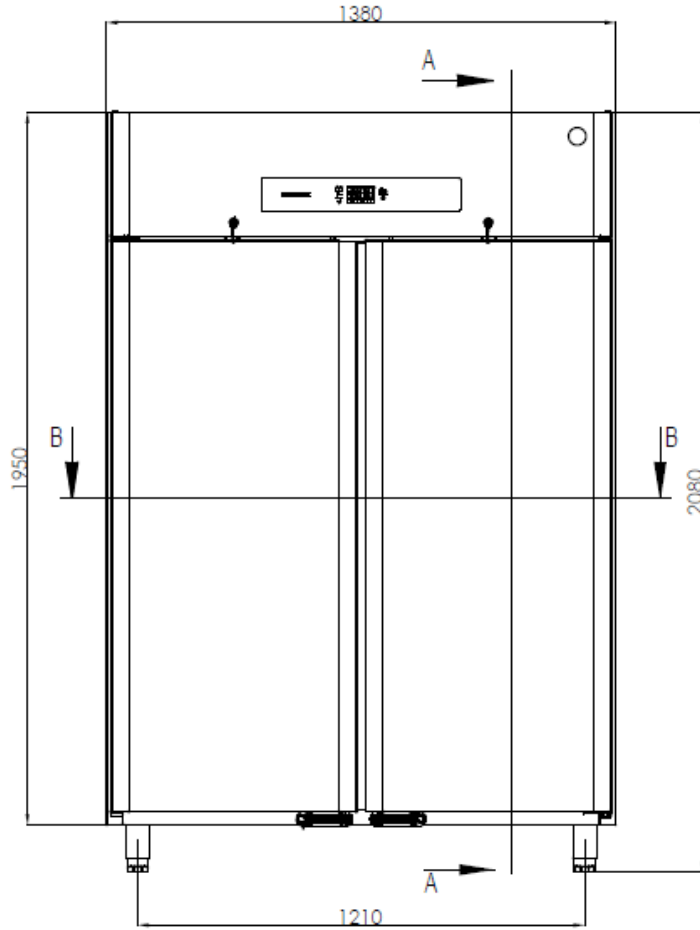

A-A

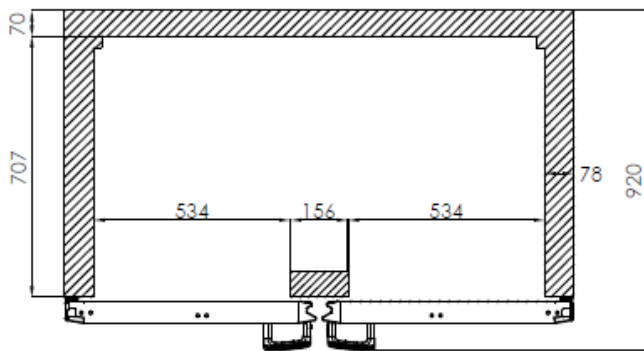

B-B

HOSHIZAKI

Premier Remote Cabinets



BAKER U 950

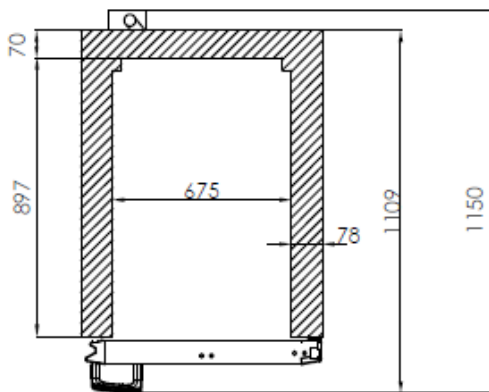
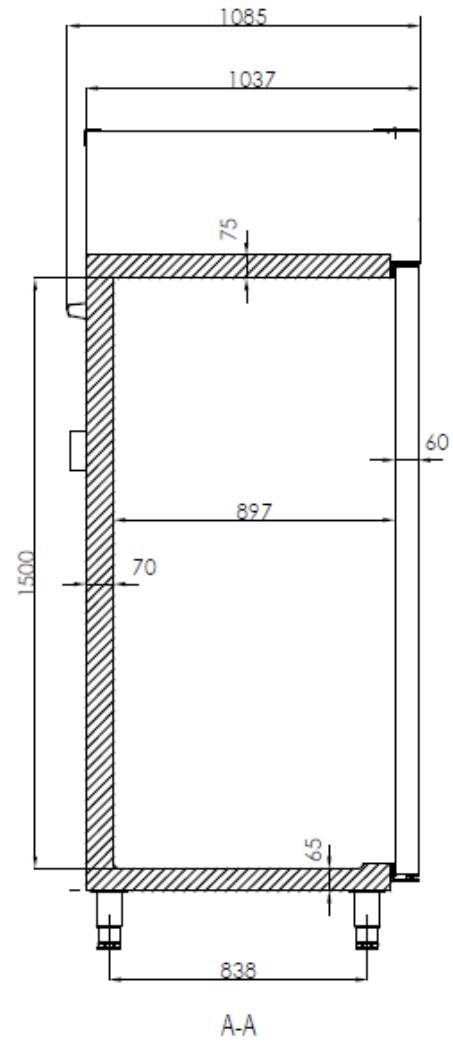
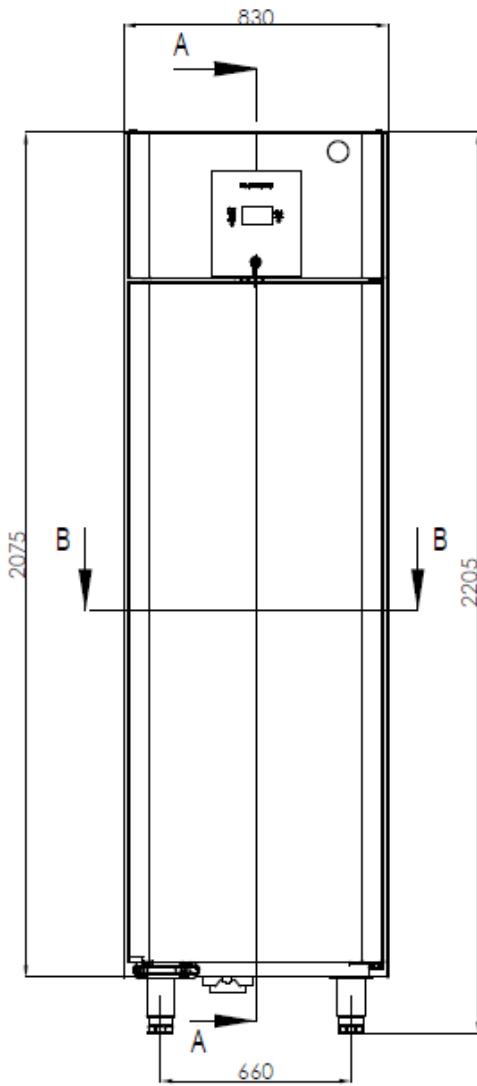

HOSHIZAKI

Premier Remote Cabinets



BAKER GA 950 (RU1)

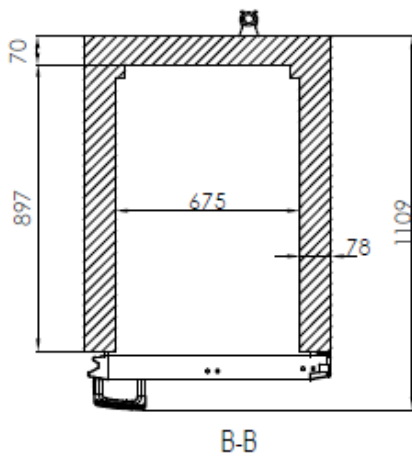
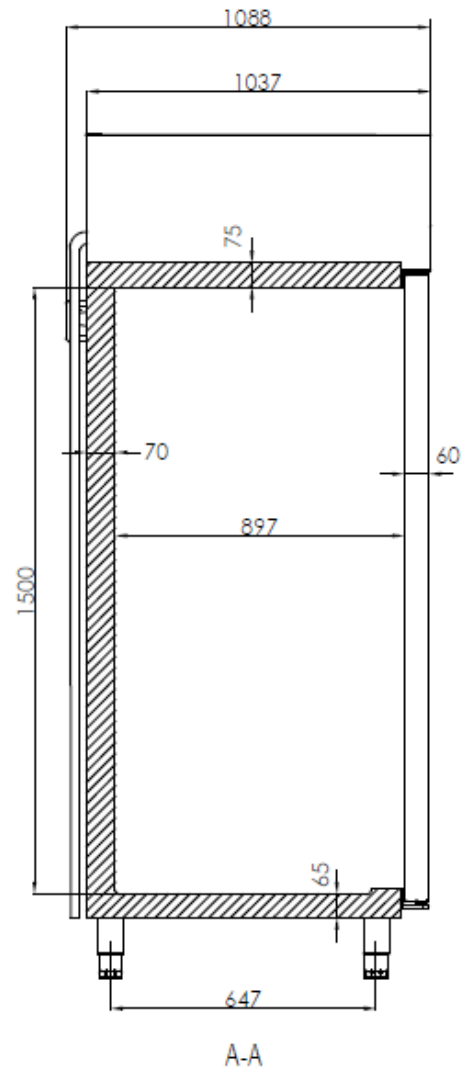
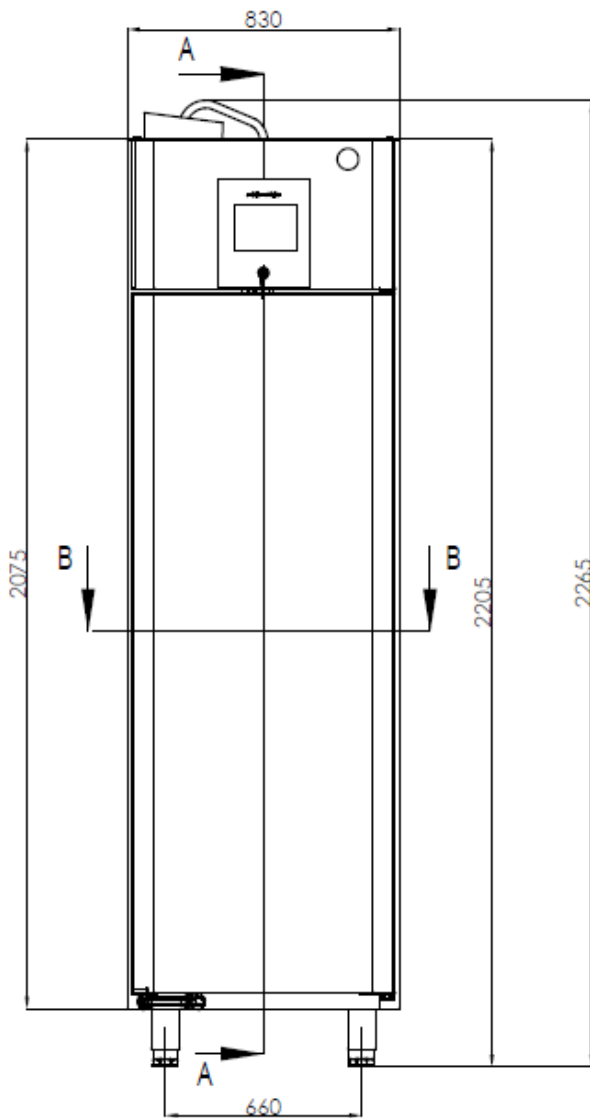

HOSHIZAKI

Premier Remote Cabinets



BAKER SF 950 (RU1)

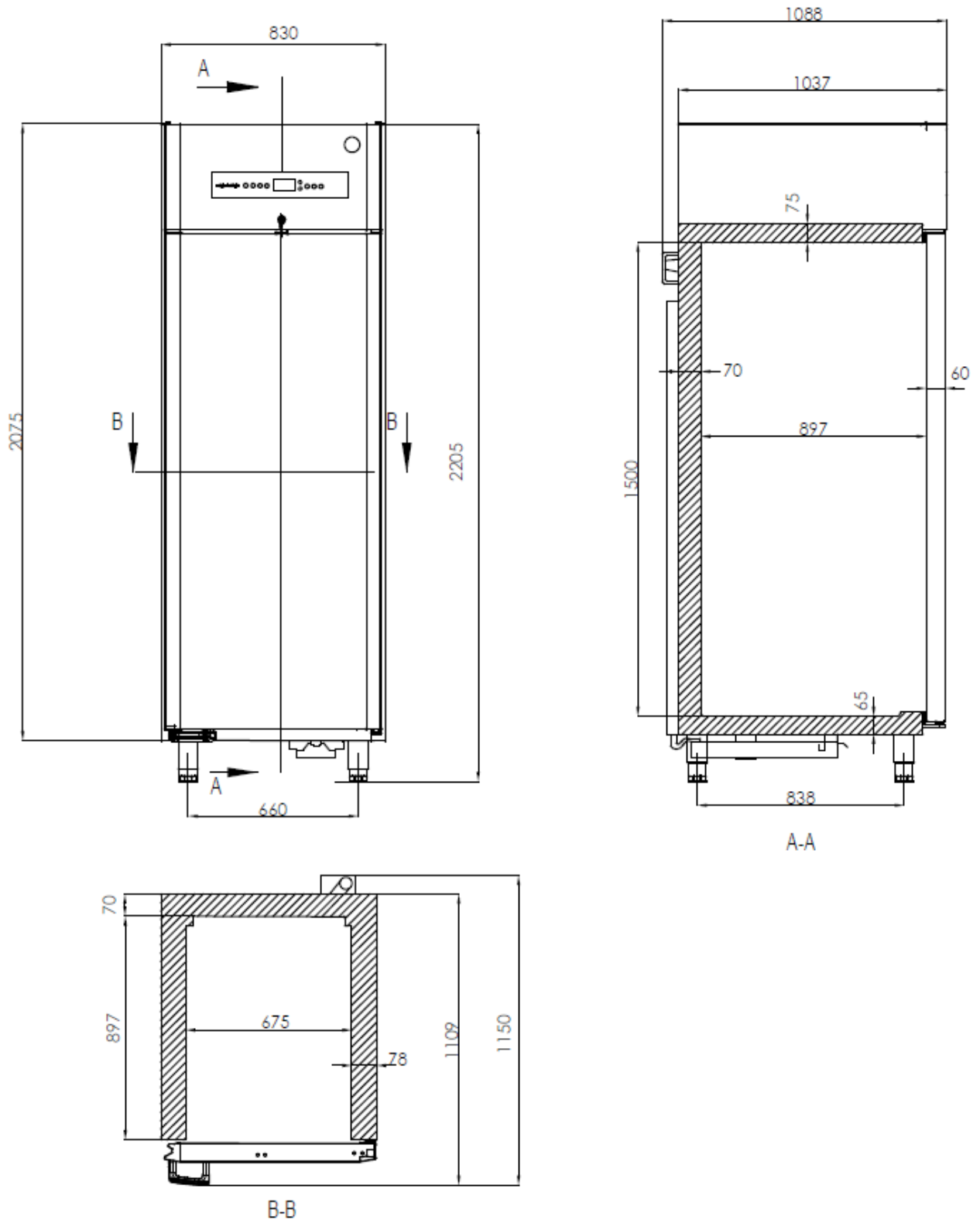

HOSHIZAKI

Premier Remote Cabinets



Kassering

Informasjonen nedenfor gjelder kun i Storbritannia.

Vi kan kun ta imot et gammelt kjøleskap ved levering av et nytt. Kjøleskap må være fullstendig avrimet og tømt før henting.

Hoshizaki erkjenner at produktene våre til matleverandører regnes som WEEE når de ikke lenger kan brukes. For å sikre korrekt og miljøvennlig håndtering av det som er Hoshizakis ansvar, har vi undertegnet den største samsvarsordningen for B2B som finnes i Storbritannia – B2B Compliance <http://www.b2bcompliance.org.uk>

B2B Compliance vil på våre vegne håndtere alle våre ansvarsområder ved innsamling og kassering av utstyr som hører innunder WEEE-direktivet for Storbritannia. B2B Compliance kan kontaktes på telefon +44 01 691 676124.



HOSHIZAKI

Premier Remote Cabinets

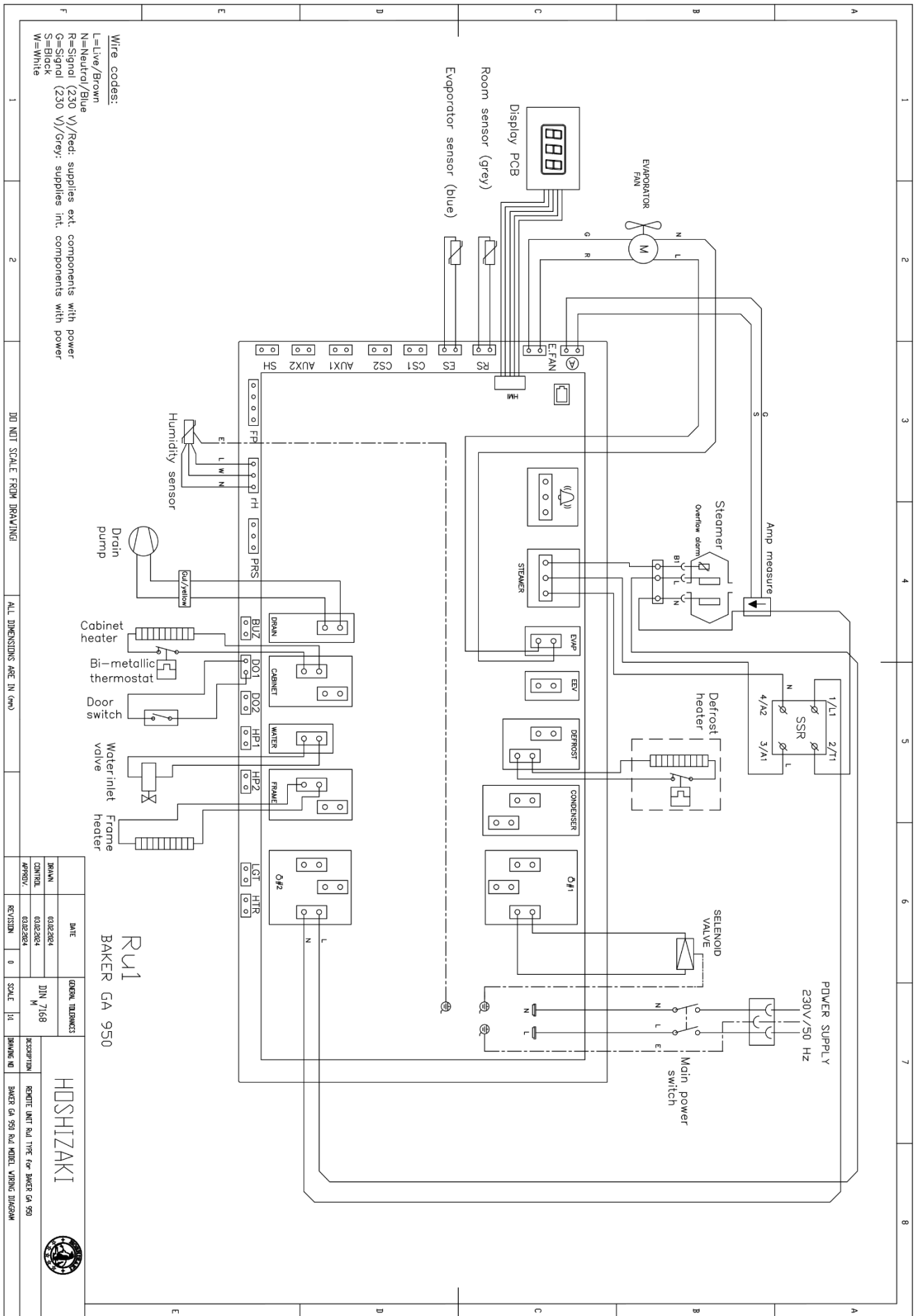

HOSHIZAKI

Premier Remote Cabinets

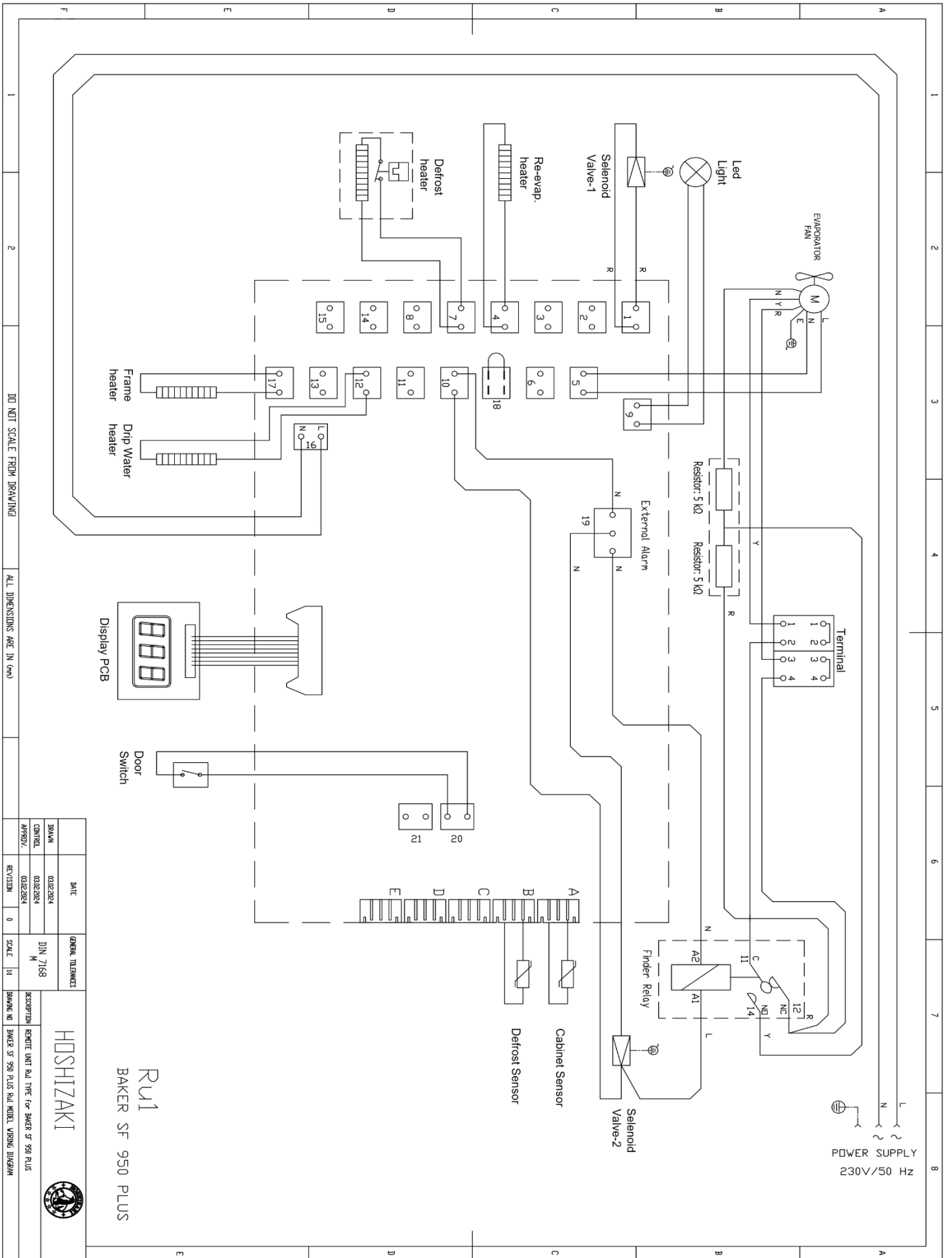

Ru1
BAKER SF 950 PLUS

HOSHIZAKI



DATE	GENERAL TOLERANCES
03/02/2024	DIN 7168
03/02/2024	M
03/02/2024	APPROV.
0	REVISION
	SCALE 1:1

DESCRIPTION: REMOTE UNIT RA1 TYPE FOR BAKER SF 950 PLUS
DRAWING NO: BAKER SF 950 PLUS RA1 MODEL WIRING DIAGRAM

DO NOT SCALE FROM DRAWING

ALL DIMENSIONS ARE IN (mm)

HOSHIZAKI

Premier Remote Cabinets

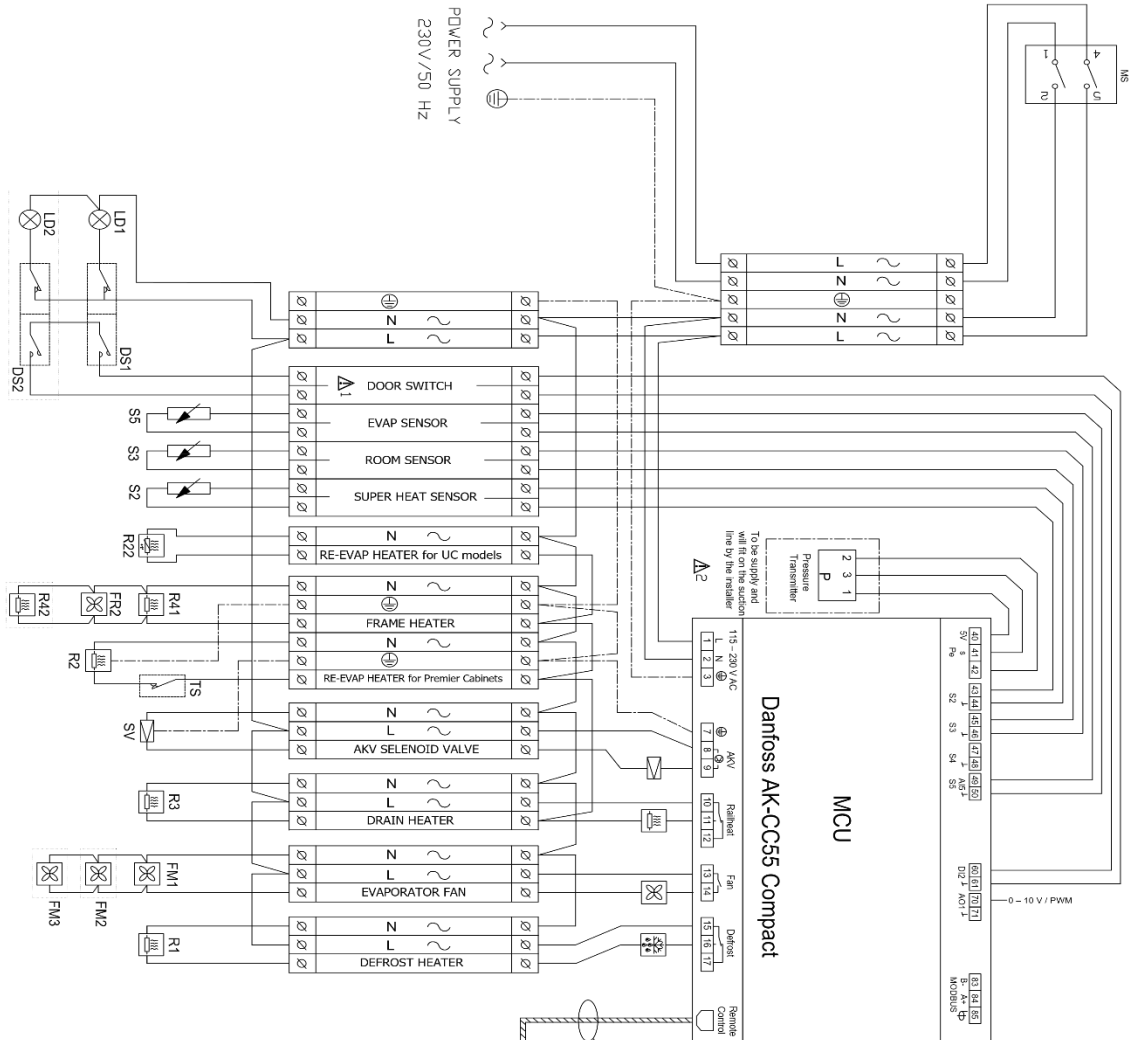

- R1: DEFROST HEATER (thermal protected)
- R2: RE-EVAP HEATER
- R22: RE-EVAP HEATER- PTC (only UC types)
- R3: DRAIN HEATER
- R41/R42: FRAME HEATER
- S2: SUPER HEAT SENSOR (PT 1000)
- S3: ROOM SENSOR (PT 1000)
- S5: EVAP SENSOR (PT 1000)
- SV: AKV SELENOID VALVE
- FM1/FM2/FM3: EVAPORATOR FAN
- DP: REMOTE DISPLAY CONTROL UNIT
- WH: REMOTE DISPLAY CABLE
- DS1/DS2: DOOR SWITCH (only cabinets)
- LD1/LD2: LED LIGHT (only cabinets)
- P: PRESSURE TRANSMITTER
- MCU: MAIN CONTROL UNIT
- TS: SAFETY THERMOSTAT
- FR2: RE-EVAP FAN MOTOR
- MS: TWO POLE MAIN SWITCH

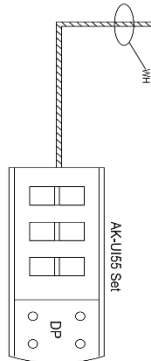

DANFOSS-C02

GENERAL INFORMATION		HOSHIZAKI	
DATE	03.02.2024	REVISION	0
BRAND	03.02.2024	SCALE	1:1
CONTROL	03.02.2024	DESCRIPTION	REMOTE UNITS IC THE DANFOSS CONTROLLER FOR ICE RETROGRAD SYSTEMS
APPROV.	03.02.2024	DRAWING NO	PREMIER-60/70/80/140 & UC MODELS WIRING DIAGRAM

DO NOT SCALE FROM DRAWING ALL DIMENSIONS ARE IN (MM)

HOSHIZAKI

Premier Remote Cabinets

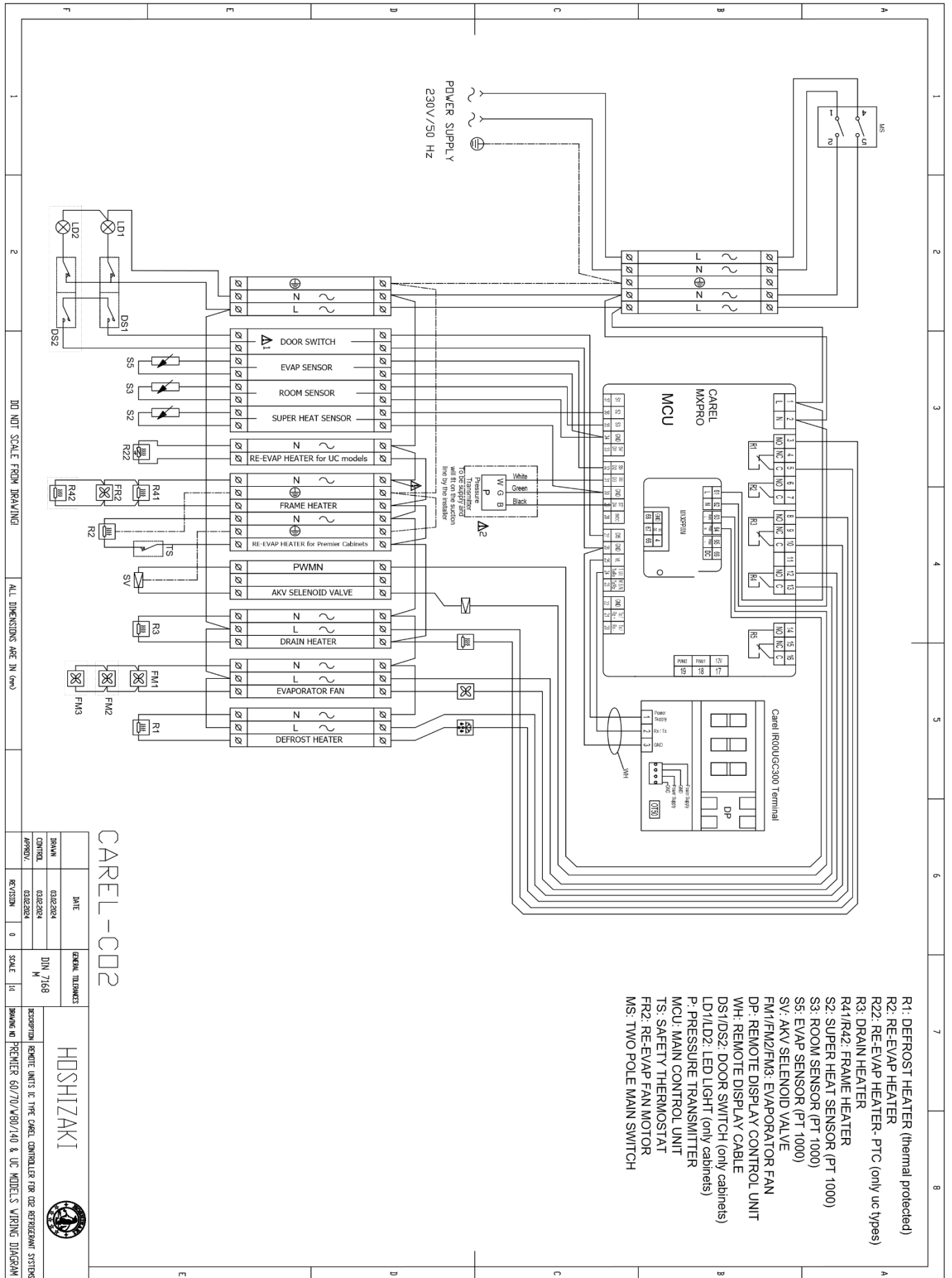

DO NOT SCALE FROM DRAWING

ALL DIMENSIONS ARE IN (MM)

CAREL-C02

DATE		GENERAL REFERENCES		REVISION	SCALE	DRAWING NO
DATE	03.02.2024	DIN	7168			
CONTROL	03.02.2024	M				
APPROV.	03.02.2024			0	1:1	PREMIER 60/70/80/140 & UC MODELS WIRING DIAGRAM

HOSHIZAKI



HOSHIZAKI

Premier Remote Cabinets

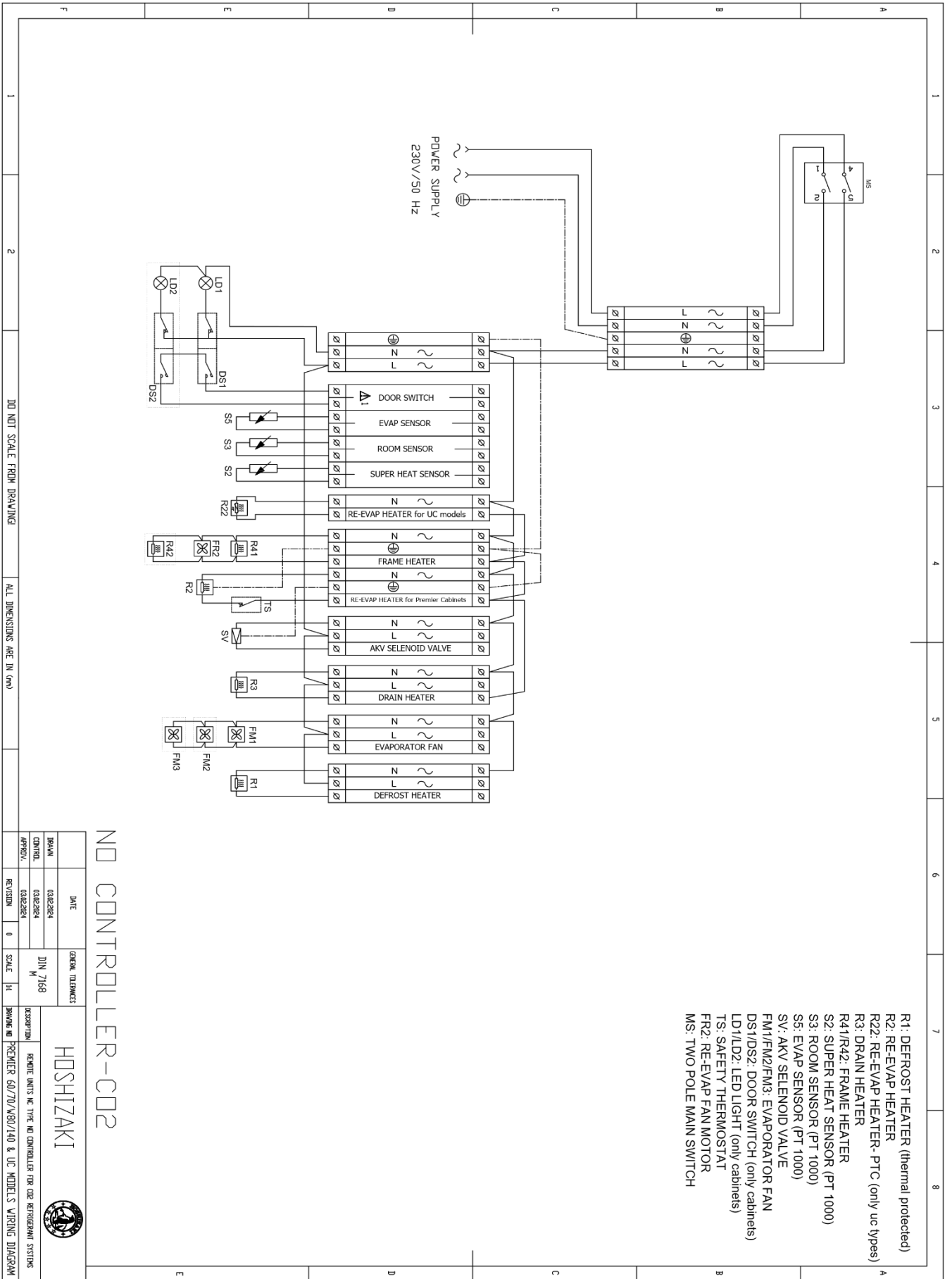

DO NOT SCALE FROM DRAWING ALL DIMENSIONS ARE IN (MM)

NO CONTROLLER-C02

GENERAL TOLERANCES		HOSHIZAKI	
DATE	03/02/2014	DESCRIPTION	PREMIER 60/70/400/140 & UC MODELS WIRING DIAGRAM
DRAWN	03/02/2014	SCALE	1:1
CONTROL	03/02/2014	REVISION	0
APPROV.			

HOSHIZAKI

Premier Remote Cabinets



Kjøleskjemaer

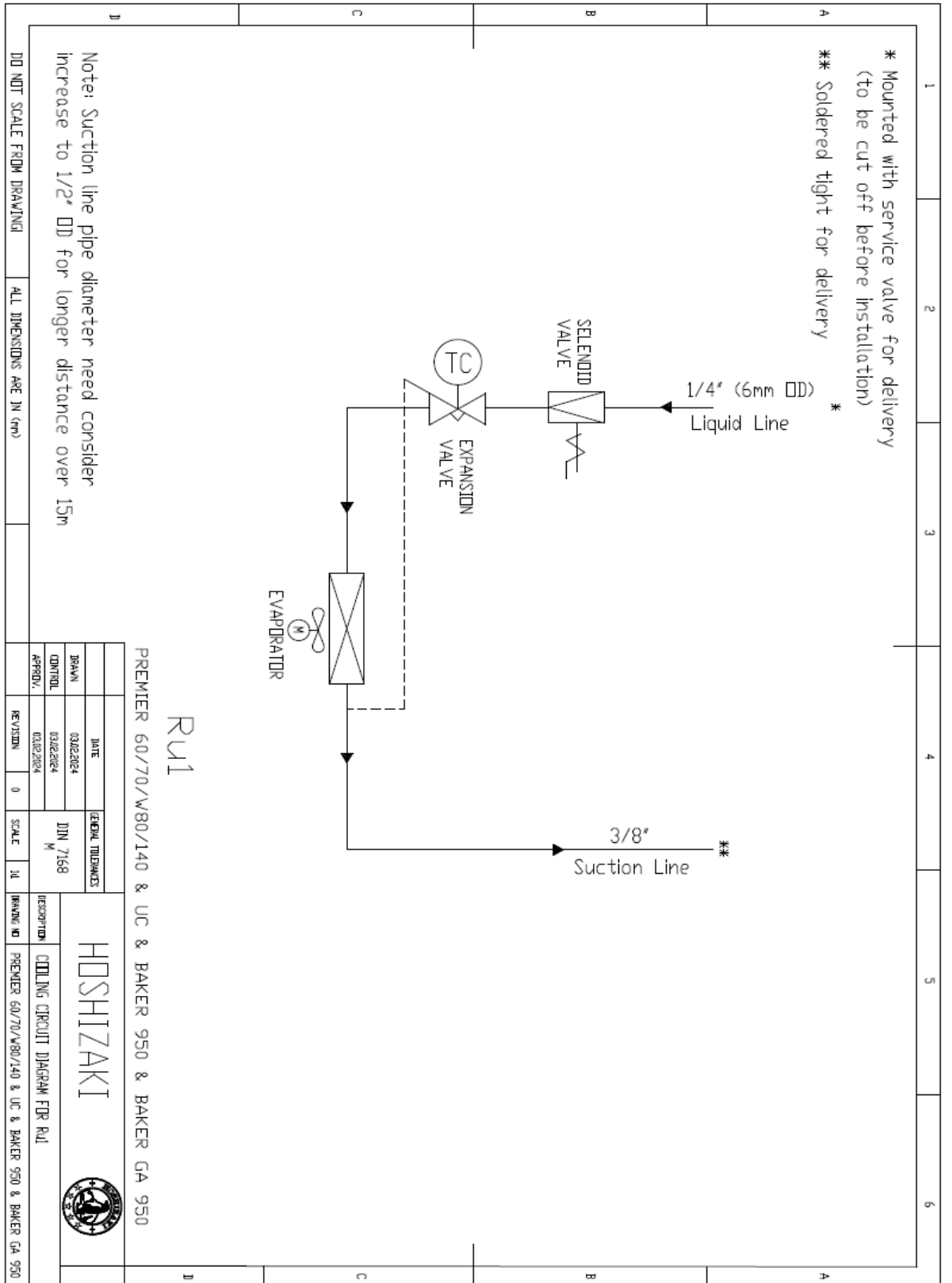

HOSHIZAKI

Premier Remote Cabinets

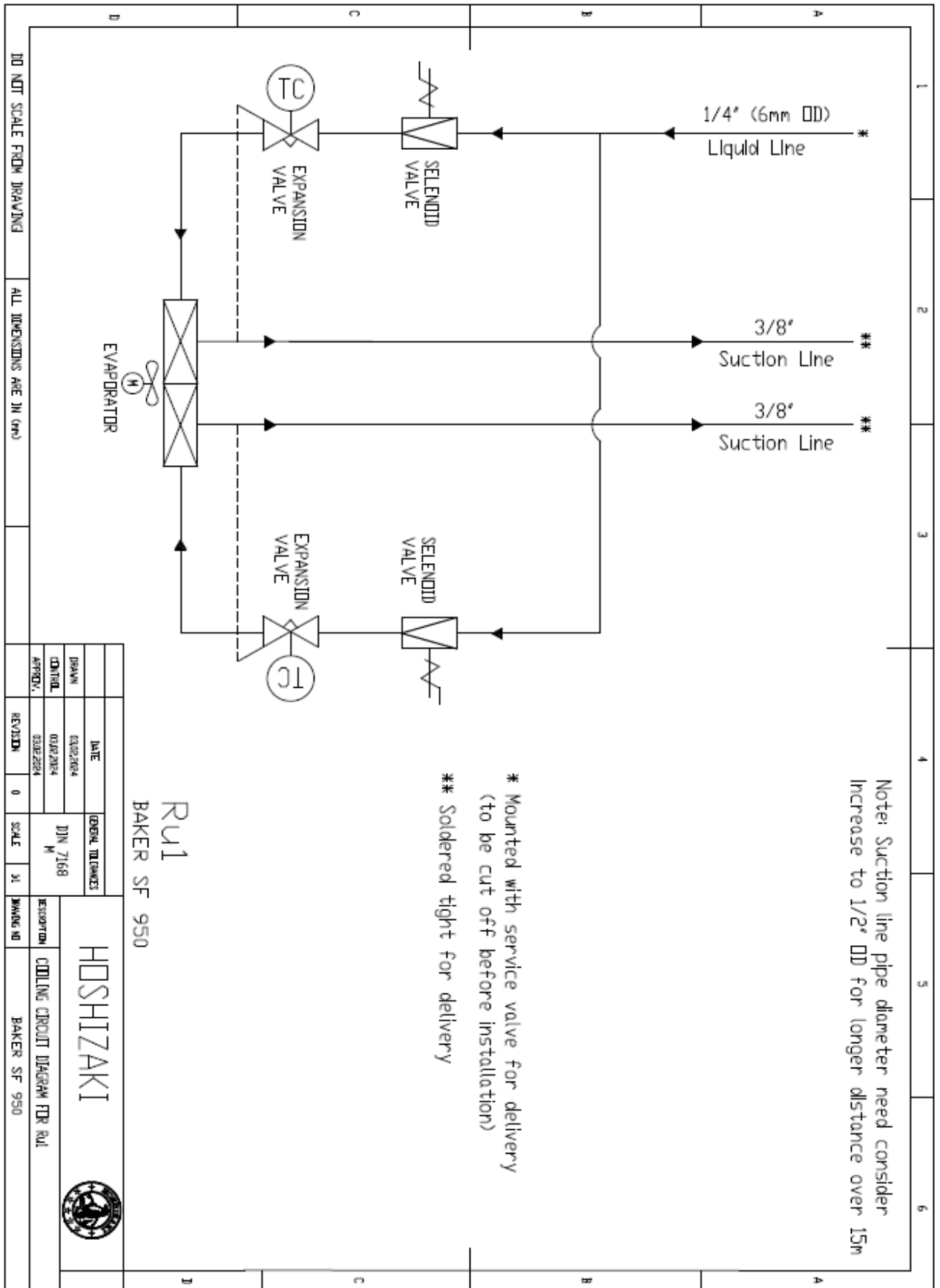

HOSHIZAKI

Premier Remote Cabinets

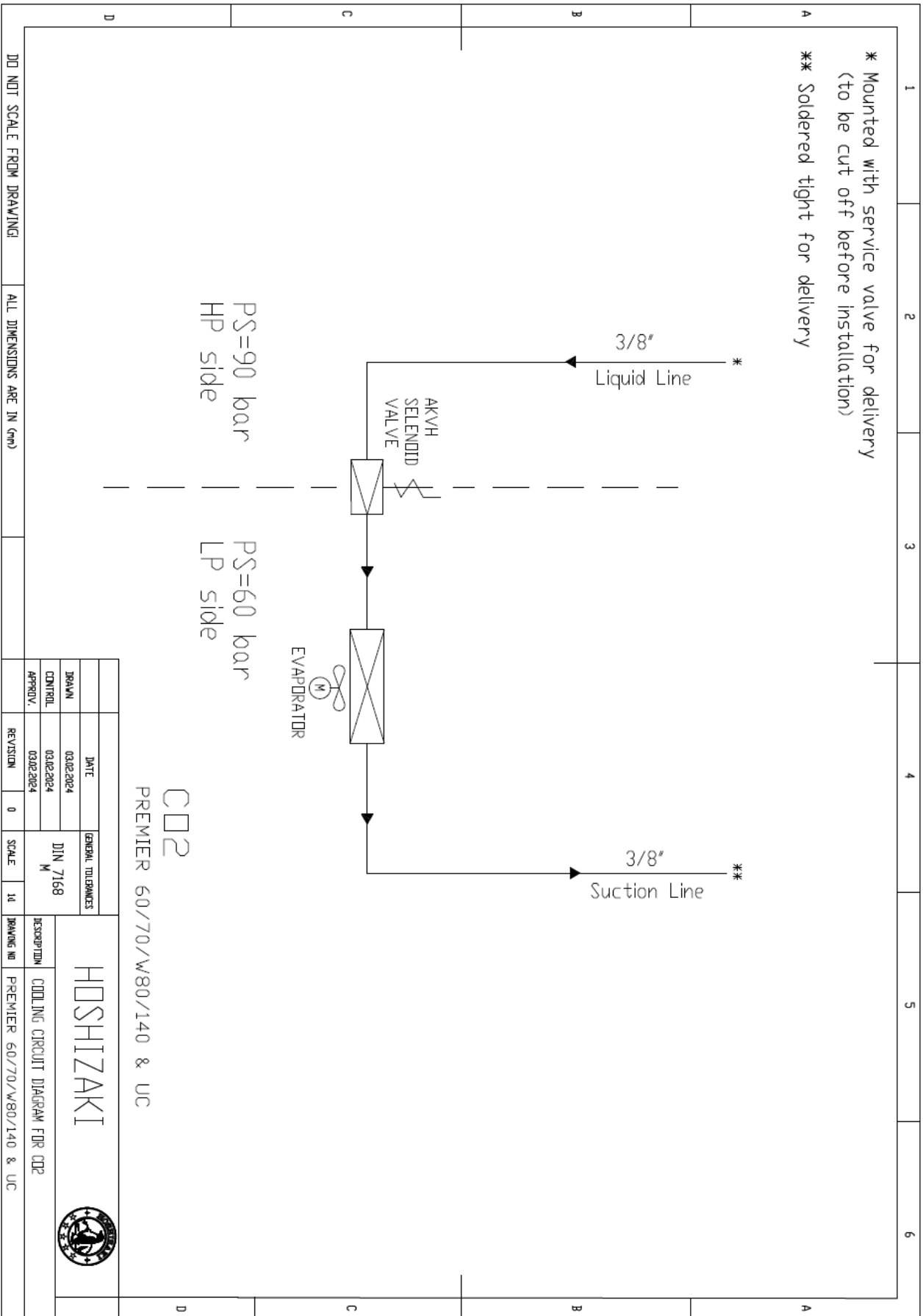

HOSHIZAKI

Premier Remote Cabinets



Med enerett

Hoshizaki forbeholder seg retten til å endre funksjoner og informasjon i denne håndboken

Kontaktinformasjon

Hovedkontorer

Hoshizaki Europe B.V.

TLF.: +31 20 691 84 99

Sales@hoshizaki.nl

<http://hoshizaki->

[europe.com/](http://hoshizaki-europe.com/)

Avdelinger

Hoshizaki UK – Storbritannia, Irland

TLF.: +44 845 456 0585

uksales@hoshizaki.co.uk

Hoshizaki Deutschland – Tyskland, Sveits, Østerrike

TLF.: +49 2154 92810, +49 5066 604612

info@hoshizaki.de

Hoshizaki BENELUX – Nederland, Belgia, Luxembourg

TLF.: +31 20 565 0420, +31 54 645 4252

sales@hoshizaki.nl

Hoshizaki France – Frankrike

TLF.: +33 1 48 63 93 80

info@hoshizaki.fr

Hoshizaki Iberia – Spania, Portugal

TLF.: +34 93 478 09 52

info@hoshizaki.es

Hoshizaki Middle East – Midt-Østen

TLF.: +971 48 876 612

sales@hoshizaki.ae

Hoshizaki Danmark – Danmark, Norge, Sverige

TLF.: +45 89 88 53 50

salg@hoshizaki.dk

Hoshizaki Europe B.V – Alle andre land i Europa og Afrika

TLF.: +31 20 565 0420

sales@hoshizaki.nl