

**GRAM**



Operating- and servicemanual  
BAKER GA 550 / 950

## Contents

Safety information .....	4
Location.....	5
Placement of multiple units next to each other .....	7
General description .....	8
Electrical connection .....	9
Humidifier .....	10
Water drain.....	11
Water connection .....	11
Adjustments related to water conductivity.....	12
General use.....	14
Commissioning, functional description .....	15
Connection and disconnection of the main circuit breaker .....	16
User interface to the unit (touchscreen) .....	17
Settings for the unit: date, time and language .....	17
Selection of language.....	18
Setting of clock (time).....	19
Setting the date.....	19
Setting of date format.....	20
Season: summer time/winter time .....	20
Temperature measurement, units of Celsius or Fahrenheit. ....	20
Setting of ending times for programs for each weekday.....	21
Preconfigured programs.....	22
Selection and start of a program .....	22
Selection of ending time for the program .....	23
Changing of established date and ending time for the program.....	24
Changing of further settings before program start.....	25
Display during program execution (fig. 32) .....	27
Changing a running program .....	28
Interruption of the currently running program .....	29
Storage of user-defined (own) programs.....	29
Manual programs .....	33
Deletion of a specially created program .....	33
Alarms/error messages .....	34
Temperature alarms .....	34
Sensor alarms.....	35
Vapour system alarms.....	35
Other alarms .....	35

Alarm log .....	36
Info I/O: Switching states and sensor values .....	37
TEST: Manual switching of the components .....	38
SET: Service parameters .....	39
Parameter list.....	41
Defrosting intervals (Storage).....	45
Entering the serviceparameters, level III .....	46
Entering level II as authorized user (owner) .....	46
Maintenance of the steam humidifier system.....	47
Flushing the steam cylinder .....	47
Cleaning the steam cylinder.....	48
Replacing electrodes.....	51
Cleaning the pump .....	52
Wiring diagram .....	56
Piping diagram .....	57

## Safety information

### ***Important***

Description of symbols used in this manual.



**Warning** Lacking observation to these instructions might result in accidents with personal injury.



**Important** If these instructions are not observed, the product might be damaged or destroyed.

Be aware that Gram Commercial has taken precautions to ensure that the safety of the product is in order.

***Please read carefully the following information regarding safety.***



It is important, that everyone who are to use or install the product, to have access to this manual.



This appliance is not intended for use by persons with reduced physical, sensory or mental capabilities, or lack of experience and knowledge, unless they have been given supervision or instruction concerning use of the appliance by a person responsible for their safety.



Children should be supervised to ensure that they do not play with the appliance.



The appliance might contain parts with sharp edges in the compressor compartment, and in the inside compartment.



The appliance is not to be transported on a sack truck, there is a danger of loosing the balance, causing danger to persons.



Do not pull the power cord to dicconnect the appliance, or when moving the appliance.

## Location

When receiving the product, check the packaging material for damage.

If any damage occurs at the packaging material, it should be considered if the product might have been damaged too. If the damage is substantial, please contact your dealer.

The transport pallet can be removed by loosening the screws that fasten the pallet to the product.



This task requires at least 2 persons. The heaviest part of the product is at the top. Be aware of this, when removing the transport pallet.

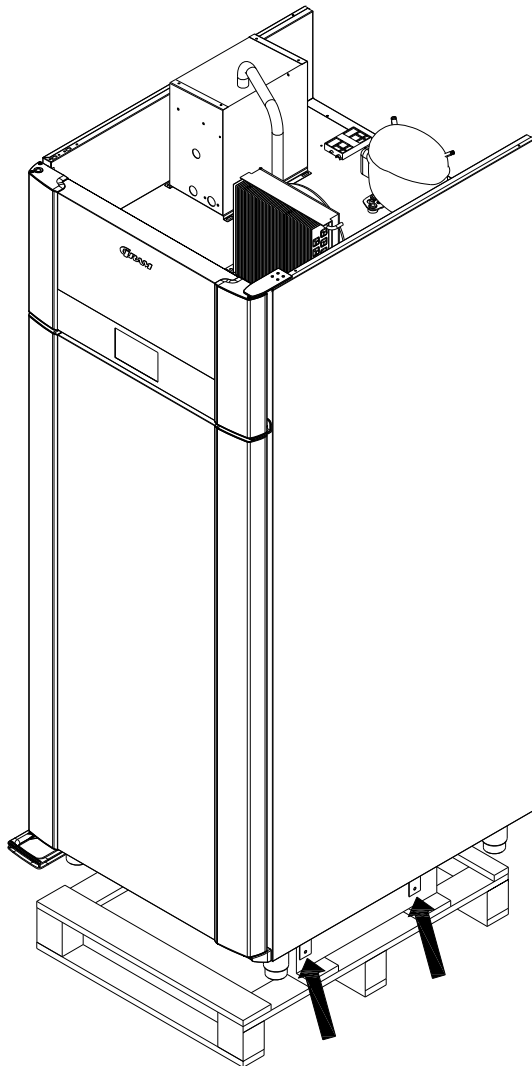

If the cabinet has been transported in horizontal position it must stand upright at least 2 hours before it is started to allow the oil from the compressor to run back.



Because of the heavy weight of the product, the floor might be damaged or scratched when moving the product.

Correct set up gives the most effective operation.

The product should be located in a dry and adequately ventilated room.

To ensure efficient operation, it may not be placed in direct sunlight or against heat-emitting surfaces. The product is designed to operate in an ambient temperature between +16°C and +40°C.

Avoid placement of the product in a chlorine/acid-containing environment (swimming bath etc.) due to risk of corrosion.

The product and parts of the interior is equipped with a protecting film, which should be removed before use.

Clean the product with a mild soap solution before use.

The set up place must be level and horizontal.

For versions with legs, use the adjustable legs to make sure that the product stands level and upright.

For versions with castors, the locking devices of the two front castors must be activated, when the product is in place. The base must be level, and the product may not be placed on frames or the like.

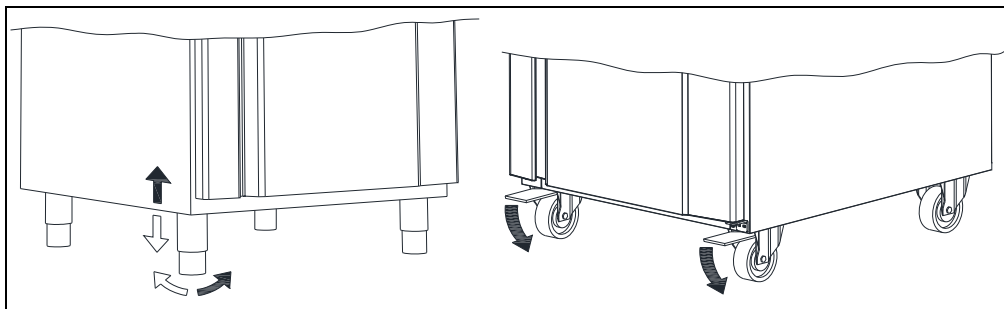

Fig. 2

## Placement of multiple units next to each other

Depending upon the temperature and humidity at the installation location as well as the correct values being set, water contained in the surrounding air may condense on the surface of a refrigerator (condensation formation) due to the design.

If multiple refrigerators or freezers are placed next to each other, then this condensation effect is stronger, plus a smaller amount of air would then circulate between the units. Hence, the minimum distance between the units must be **40 mm**.

This space must not be closed off at its top or bottom, however due to aesthetical considerations it may be covered in the front by, for example, a stainless steel panel. In order to be able to clean this space, the panel must be detachable.

If it is not possible to establish free air circulation at the bottom via, for example, installation on a pedestal, then the space must not be fully sealed at the front.

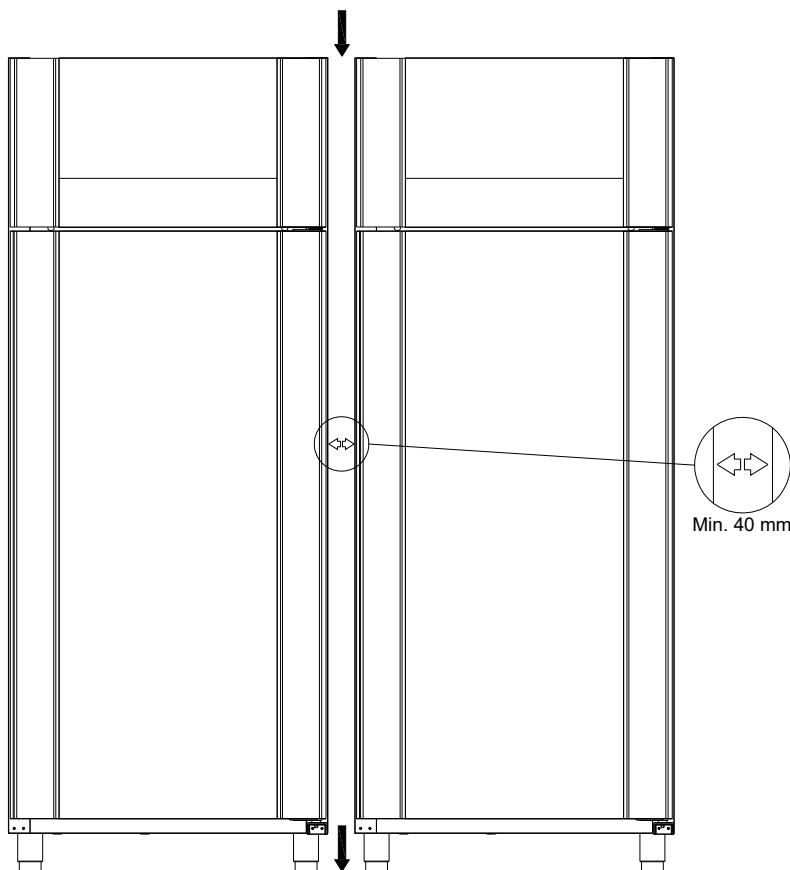

## General description

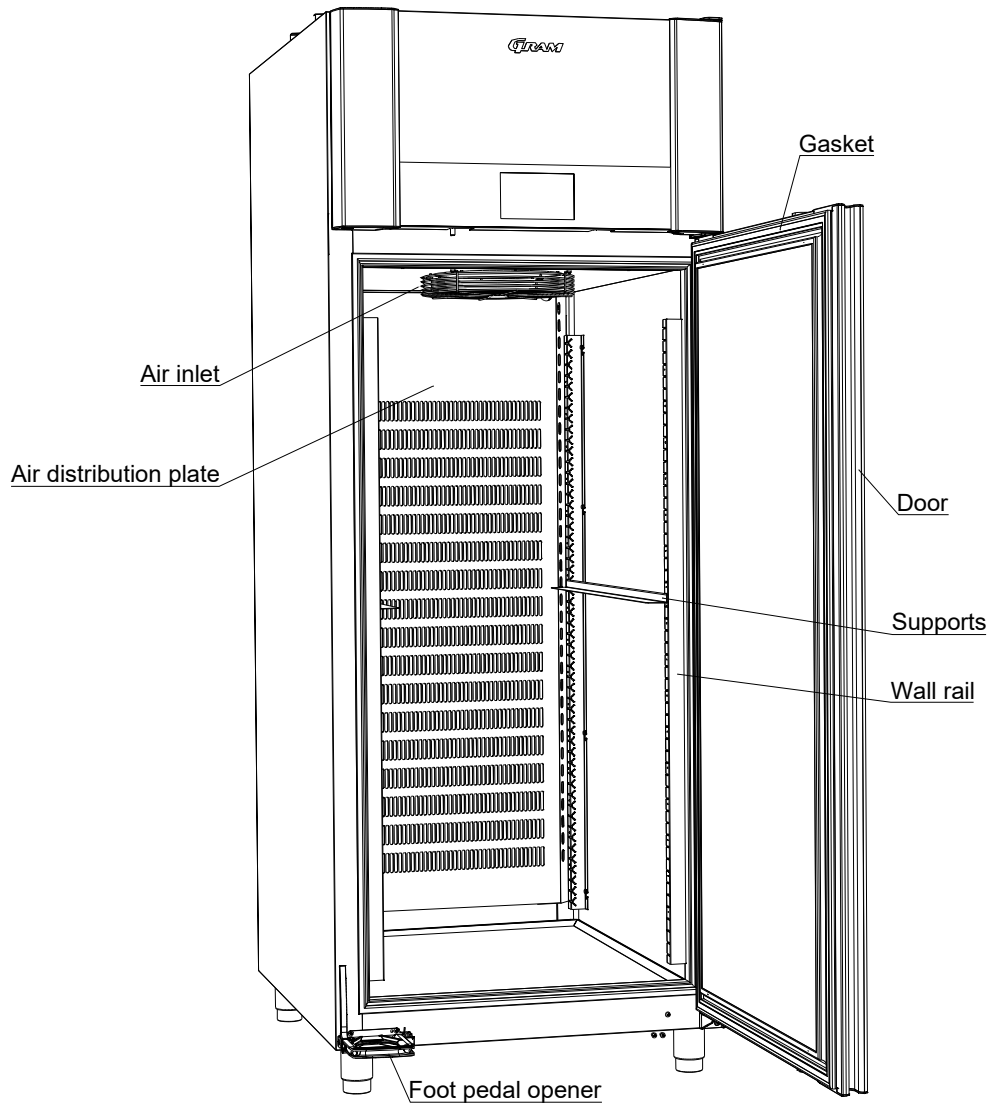
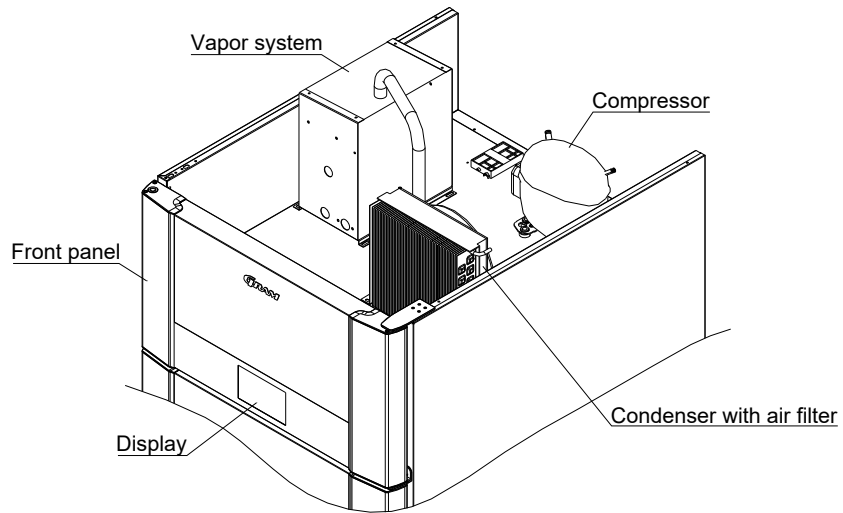

## Electrical connection

Read the text below thoroughly before electrical connection.



The product is intended for connection to alternating current. The connection voltage (V) and frequency (Hz) are shown on the name plate in the cabinet. Only the supplied cord is to be used.



Never use an extension cord for this appliance!  
If a wall socket is placed in a longer distance than the length of the supplied power cord, contact an electrician to establish a wall socket within the range of the supplied power cord.



If the product is defective, it must be examined by a service electrician advised by Gram Commercial during the guarantee period, if it is a product with built-in compressor.

If it is a product connected to an external compressor unit, it must be examined by the company who has connected the product to the unit.

Outside the guarantee period, it is advisable to use the service advised by Gram Commercial, if possible. If this is not the case, assistance is required from a refrigeration company with knowledge of Gram's products.

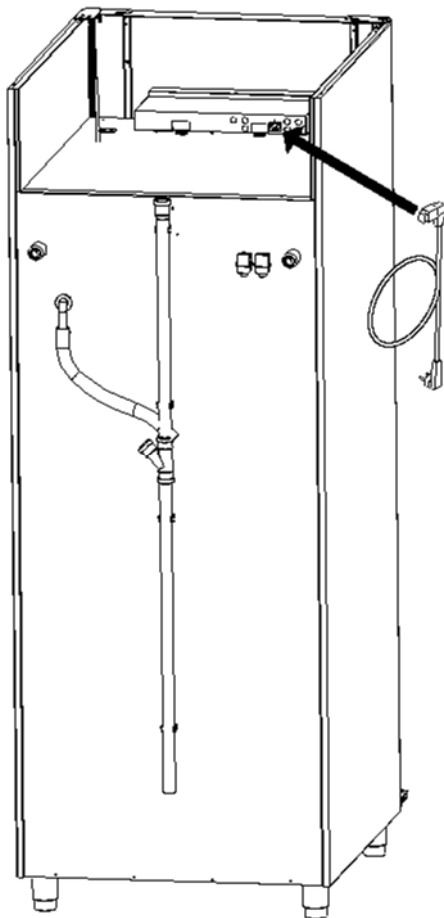

Always disconnect the power if interruptions in power supply occur, and when electrical parts are removed/put on, and before cleaning and maintenance of the product.

Repairing of electrical/technical parts may only be performed by a service electrician from Gram Commercial or an authorised refrigeration company with knowledge of Gram's products.

Do not use the product before all coverings are installed, so that live or rotating machine parts can not be touched.

The product is not to be used outdoor.

All earthing requirements stipulated by the local electricity authorities must be observed. The plug and wall socket should then give correct earthing. If necessary, contact an electrician.



Make sure the product is switched off at the socket before service is performed on electrical parts. It is not sufficient to switch off the product by the START/STOP key as there will still be voltage to some electrical parts of the product.

## Humidifier

The cabinet is equipped with a humidifier that provides steam during proving. The humidifier consists of a water tank heated by electrodes. From the tank, steam is led into the cabinet through a pipe. The tank is automatically filled from the water supply.

The tank can be flushed by switching the cabinet off at the main switch and then switching it on again. In addition, the system is automatically flushed regularly depending on water quality.



For further information on servicing and maintaining the humidifier, please consult the "Service and operation manual". For maintenance of the humidifier, request service assistance.

## Water drain

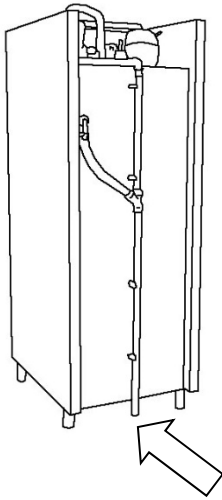

Defrost water and water flushed from the humidifier are led away through a pipe on the rear of the cabinet. A water seal must be installed between cabinet and drain.

## Water connection

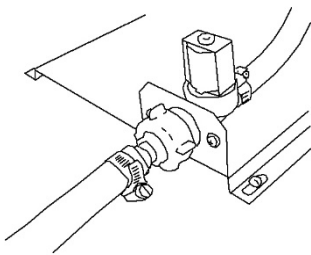

To provide proper steam production, the humidifier must be connected to a water supply. To assure ideal steam production, it is important that the electrical conductivity of the inlet water is measured by the installer, to assure it is within standard range. See Below Box!



Please note the following:

The electrical conductivity of the water must be in the range: 200-800  $\mu\text{S}/\text{cm}$ .\*

The temperature of the inlet water must not exceed 40°C.

The water pressure must be in the range 1-10 bar.

A shut-off valve, a check valve, and a filter if necessary, must be fitted to the supply pipe.

\*If the electrical conductivity of the water is outside the above mentioned standard range (200 – 800  $\mu\text{S}/\text{cm}$ ) some controller settings, might need adjustment in order to maintain proper steam production. These adjustments must be done by a service technician, and are described in the next part of this service manual.

Indications that water conductivity is outside of standard range are:

- Too poor steam production
- Frequently having boiler overfilled alarm

## Adjustments related to water conductivity

In order to gain access to the area where the settings related to the water conductivity can be adjusted, it is necessary to access the service level of the controller (level III). How to access this area is described under “Entering the service parameters, level III”. After entering this level it is necessary to go back by pushing the button  (arrow back).

When this is done being in level III, you will see the accessible/highlighted SET button (picture below). This button must be pushed in order to access the parameters.



The parameters which must be adjusted are under the rH tab. The first parameter under this tab is H01.

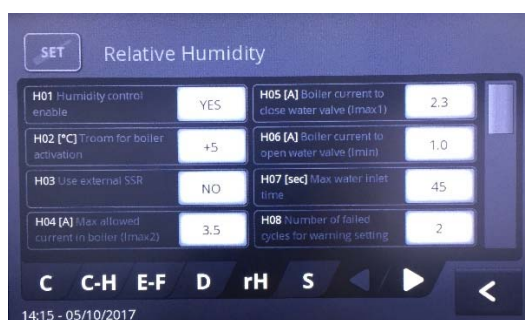

In order to be allowed to adjust the H04 current to exceed 3,5 amp, there **must be fitted** an external SSR. This SSR has been the standard in the Gram production since the 2<sup>nd</sup> of October 2017.

If this external SSR is fitted, the H03 parameter must be set to YES, in order to extend the amp range to a maximum of 7,5 amp.

If the external SSR is not fitted, **it is not** allowed to change the parameter H03 from NO to YES, before the external SSR has been fitted, otherwise the controller will be damaged. If the external SSR is fitted on a cabinet build before the 2<sup>nd</sup> of October 2017, it is of great importance, that the controller software is updated. This update is very important because compressor relay 2 is used to power the main supply of the SSR (see the wiring diagram). This function is only available in the software used after the 2<sup>nd</sup> of October 2017. If the software is not updated the electrodes of the boiler will not be supplied with 230 Volt, which will result in no steam production. For advice regarding what external SSR service kit and software to use and how to fit it, please contact technical support.

After measuring the conductivity of the tap water, which the cabinet is connected to it can be decided if adjustments to the controller are necessary. If the conductivity of the water is outside the standard range of 200 to 800  $\mu\text{S}/\text{cm}$ , the below adjustments can be made in order to minimize the number of potential failures related to the boiler operation and to optimize the steam production.

Conductivity $\mu\text{S}/\text{cm}$	Amp. H04	Amp. H05	Amp. H06	Sec. H07	Notes
50	NA	NA	NA	NA	Water with conductivity < 150 $\mu\text{S}/\text{cm}$ cannot be used
150	6,5	2	1	60	
200	6,5	2,3	2	60	
400	6,5	2,3	2	60	
600	6,5	2,3	2	60	If the boiler does become too "nervous" the parameter H05 can be raised to 3,0 amps
800	6,5	2,3	2	60	If the boiler does become too "nervous" the parameter H05 can be raised to 3,0 amps
1000	6,5	3	2	60	
1200	6,5	3,5	2	60	

If the conductivity is below 200 or above 600 $\mu\text{S}/\text{cm}$  it can be necessary to adjust H05 and H06 depending on the water pressure on sight.

## General use



Do not block vent holes in the front panel.



Do not damage the refrigeration system parts.



During normal operation, some parts of the refrigeration system in the compressor compartment might reach high temperatures, and could therefore cause burns if touching these components.



Do not use electrical devices inside the product.



To ensure correct and efficient air flow in the cabinet, the shaded areas must be kept free of items.



All items to be stored, that are not wrapped or packed, must be covered in order to avoid unnecessary corrosion of the inner parts of the cabinet.



If any controller parameters are changed from default, this could cause that the product is not functioning normally, and harmful temperatures could damage items that are kept inside the product.



If the product is turned off, wait minimum 3 minutes before turning it on again. This is to protect the compressor from damage

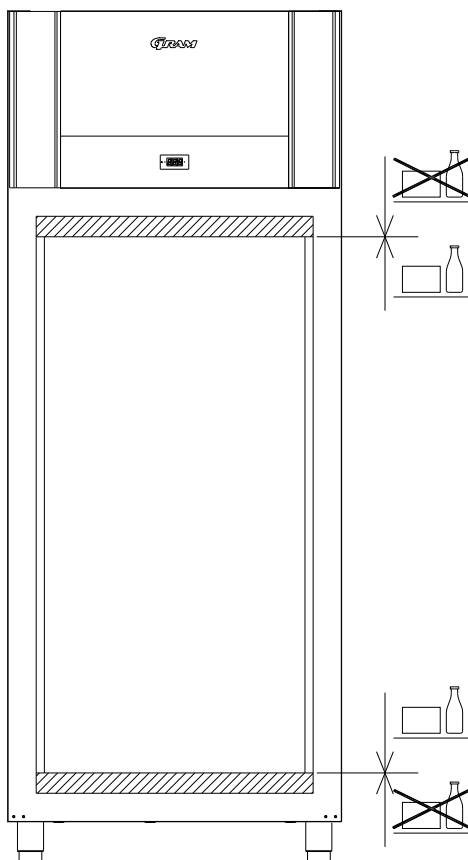

## Commissioning, functional description

In order to ensure reliable processes for Freezing, Storage, Thawing, Proving and Holding the cabinet must be furnished with controls to regulate the air temperature, ventilation and relative humidity.



The operating modes of Storage, Thawing, Proving and Holding can be connected up manually.

This means that the unit can also be used as a normal refrigerator or freezer in a storage program with a constant temperature. With the thawing and proving operating modes, the relative humidity is instead kept constant while the temperature varies.

Correct programming of the controls establishes the desired combination of the operating modes:

- time-controlled freezing with subsequent storage for an arbitrary length of time
- time-controlled freezing with subsequent storage and time-controlled thawing as well as subsequent maintenance of the climate upon conclusion of the thawing program
- complete program with freezing, storage, thawing and proving until being taken out or holding when the roux time is exceeded.

## Connection and disconnection of the main circuit breaker

The unit is furnished with a two-pole main breaker, which is located behind the tiltable control panel. When it has been disconnected, the controls and all components that are accessible without opening the control panel are disconnected from the power supply. If the main breaker is connected, then the controls and the other components are connected to the power supply.

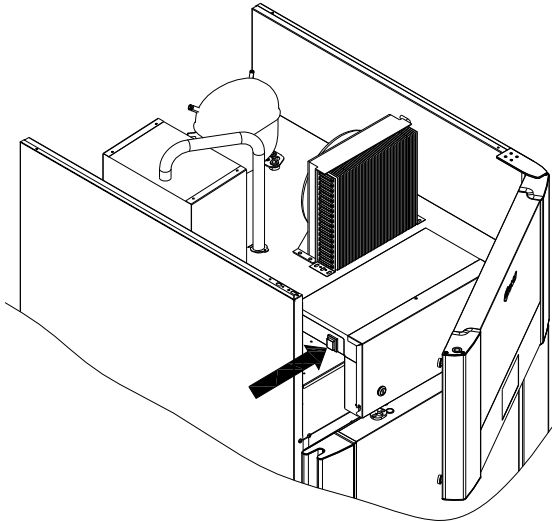

When working on the electrical equipment, the unit must always have its power from the grid shut off by disconnecting it and then pulling the plug out of the power socket. It is **NOT** sufficient to disconnect the unit with the ON/OFF button because certain parts of the unit will still have an applied voltage.

## User interface to the unit (touchscreen)

All operating functions are performed by touching the respective buttons displayed on the touchscreen, for example changing values and starting and stopping programs. In connection with this, the function is "touch and release", which in other words is that the controls react to being touched once you let go of the keyboard.

When the unit is connected with the lighting mains, and the main breaker switched on, then the standby display is shown on the screen: (fig. 1). The Gram logo and the unit type "GA 950" as well as the date and time are shown on a field with a blue background. Please check that the correct date and time are displayed.

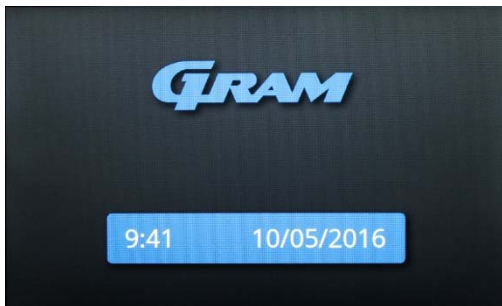

Fig. 1

If the date, time or selected language are not displayed correctly (date format), go to the section entitled "Settings for the unit: date, time and language" (see below) in order to change the settings.

When the display is touched, the controls change from standby to the first on-screen menu (fig. 2):



Fig. 2

This menu is the **start menu** for all further functionality. If the unit is in the process of running an active program, and you do not touch the screen for 30 minutes, then the controls will switch back to the standby display (fig. 1)

## Settings for the unit: date, time and language

In order to change the settings for the date, time, formats, units or menu language, you need to press the button  on the keyboard (machine symbol) in the lower right corner of the screen (fig. 3). The factory setting for the language is English.



When you press the button , the menu for settings for the unit opens (fig. 4):



Fig. 3



Fig. 4

To set the date, time or language, press the button . The settings menu then opens with the associated fields (fig. 5):

## Selection of language

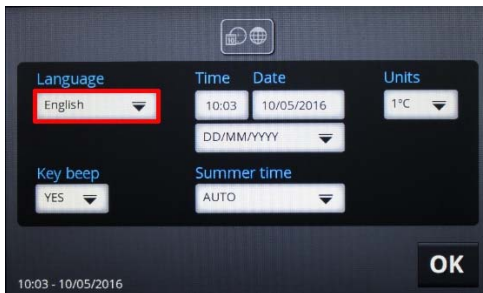

Fig. 5

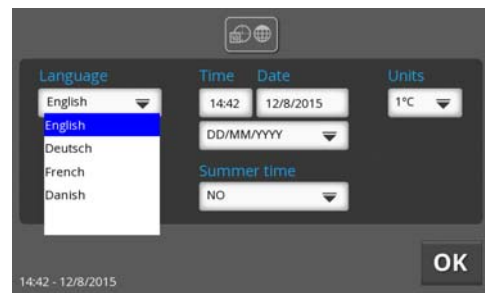

Fig. 6

When you touch the fields, the pull-down menus are opened and the possible values displayed. Fig. 6 shows the language selections. The desired language can be selected by touching it.

It is important to restart the controls to ensure that this change has been performed for all areas.

## Setting of clock (time)

The clock is set by touching the field with the time under the text "Time" (fig. 7):

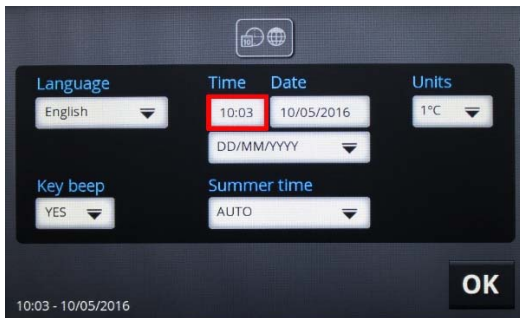

Fig. 7



Fig. 8

Enter the desired time directly using the numerical keypad and confirm with the "OK" button (fig. 8). The clock works with days in 24-hour format. It is not possible to use a 12-hour format ("am"/"pm"). After pressing the "OK" button, the time is saved and the display returns to the previous menu (fig. 5). Exit the menu without making any changes by selecting "<".

## Setting the date

The date is set by pressing on the date field under the text "Date" (Fig. 9)



Fig. 9

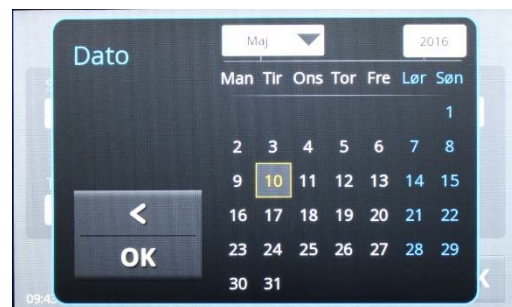

Fig. 10

A calendar menu will be displayed (fig.10). Here, you must select the month, year and day, and then confirm with "OK". Exit the menu without making any changes by selecting "<". The previous menu is then displayed (fig. 5).

## Setting of date format

Set the date format by pressing the "DD/MM/YYYY" field (fig. 11).



Fig. 11



Fig. 12

The choice between the sequence day/month/year and month/day/year is now shown (fig. 12): Select by pressing.

## Season: summer time/winter time

Setting of the season, i.e. the setting of winter/summer time is done by pressing on the field under the text "Summer time" (fig. 13):

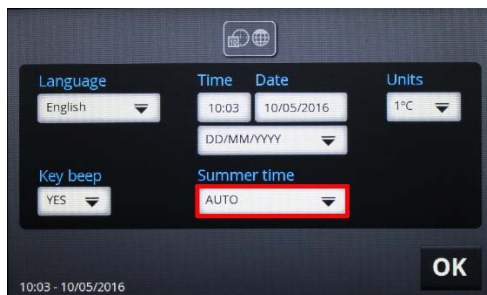

Fig. 13

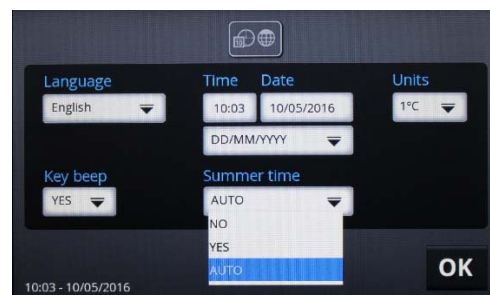

Fig. 14

Possible choices:

**"NO"** = manual selection of winter time (system time)

**"YES"** = manual selection of summer time (system time + 1 hour)

**"AUTO"** = automatic switching to Central European Summer Time, CEST:  
Start on summer time: last Sunday in March  
End of summer time: last Sunday in October

The factory setting is "AUTO". Select by pressing.

## Temperature measurement, units of Celsius or Fahrenheit.

Setting the unit to display temperatures in Celsius or Fahrenheit is done by pressing the field under "Units" (fig. 15):



Fig. 15

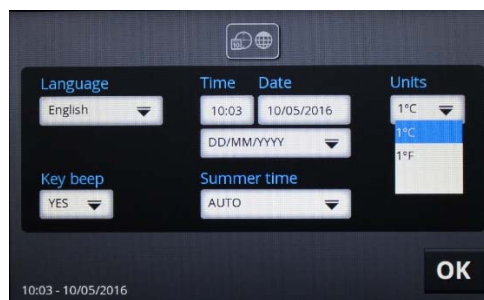

Fig. 16

Here, you can choose to display temperatures in Celsius or Fahrenheit for all displays in the controls (fig. 16).

When you have made all the changes to the settings, then return to the Settings menu (fig. 4) for the unit by pressing the "OK" button (fig. 16).



Fig. 17



Fig. 2

Return to the start menu (fig. 2) by pressing the field  (arrow back) in the lower right corner (fig. 17).

## Setting of ending times for programs for each weekday

In order to take weekends and holidays into consideration, an ending point in time can be established for programs for each weekday as a default. This is then shown upon later program selection, and you only need to confirm it by choosing "morning".

Press the button in the keyboard  (machine symbol) in the start menu (fig. 3, page 16). The menu for settings for the unit now opens (fig. 18).



Fig. 18



Fig. 19

Press on the "Calendar page" (fig. 18) in order to open the ending time menu for the program (fig. 19). When you press on the white fields with the times for the day, a settings menu opens, where you can enter the time (fig. 20).

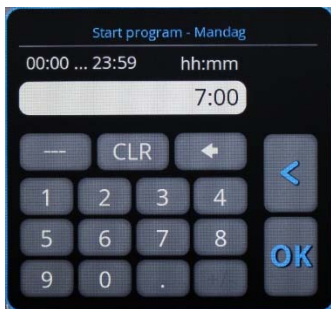



Fig. 20



Fig. 20a

Enter a time. In order to jump over a day, the symbol „---„ (fig. 20a) needs to be inserted on the desired day. With "OK", you save what you entered for this weekday, or you can return  to the weekly overview (fig. 19) without saving.

Once all the changes have been made, you return to the start menu by pressing  twice, (fig. 20a).

## Preconfigured programs

There are five preconfigured programs stored in the controls, which can be selected directly in the start menu under the overview  (fig. 21). These programs cannot be deleted or overwritten.



Fig. 21

## Selection and start of a program

In order to start a preconfigured program without changing the settings, you press on the button on the keyboard with the symbol Master. The selected symbol is shown with a blue edge, and the "Settings" button (symbol for the sliding button) is shown in blue, which means that it has been activated (fig. 22).

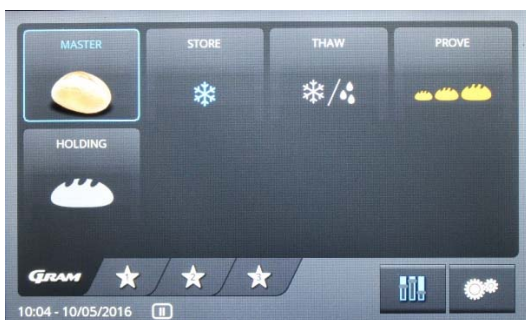



Fig. 22

Further touching of the Master symbol opens a window with an ending time for the program (ready at) on the following day.

## Selection of ending time for the program

A menu is opened in which the ending time for the program is selected, and the default - setting of "Weekday" must be confirmed (fig. 23).

The usual ending time for programs can be established in the menu Settings for the unit  as a default value for each weekday (see the section entitled "Default ending times for programs for each weekday", page 21).

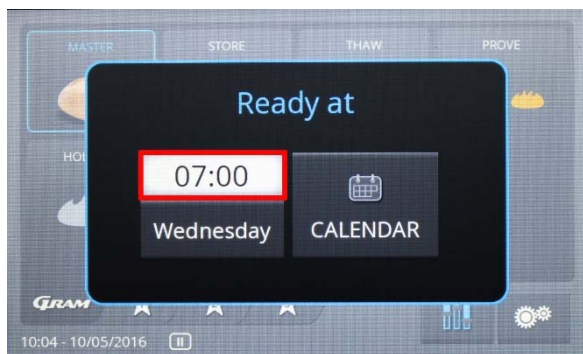

If the ending time established for the program is correct, then the program can be started by choosing "Weekday" (Monday, Tuesday, etc.). The program only starts if there is sufficient time remaining between the time for the starting and ending times for the program for the sum of the programmed program sections (phases). Otherwise, the earliest possible ending time for the program is shown (fig. 23).

**To switch out of the display, press on "Ready at".**

## Changing of established date and ending time for the program

To do this, press on the "Calendar" field (fig. 26)

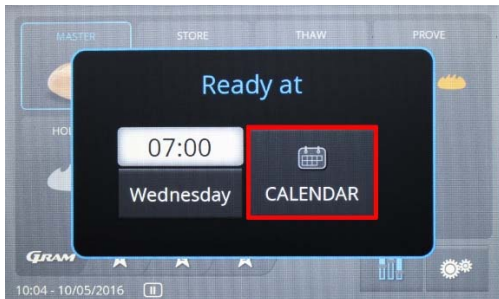

Fig. 26



Fig. 27

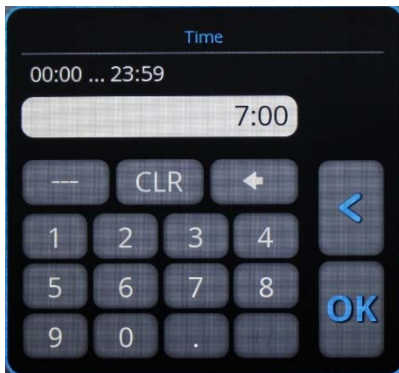

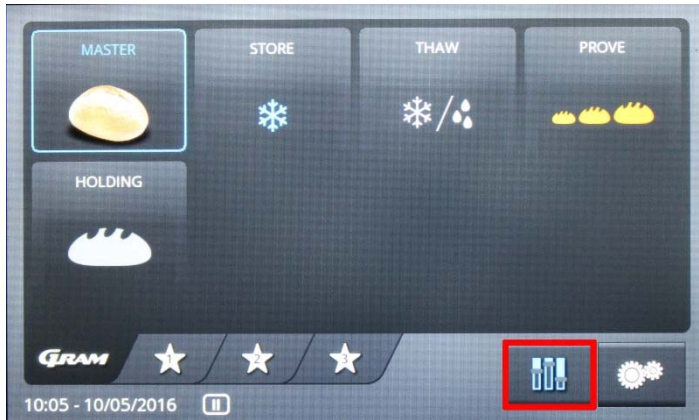

Fig. 20

The calendar menu (fig. 27) will be displayed. Here, the date can be changed by touching the date fields. Selections for changing the time can be opened by touching the time window. Here, the time can be entered and then saved with "OK". By selecting  you exit the menu without making any changes. With "OK" you exit the menu and start execution of the program.

## Changing of further settings before program start

In order to adjust a preconfigured program, touch the button on the keyboard with the Master symbol. The selected symbol is displayed with a blue edge, and the "Settings" button (symbol with sliding button) is shown in blue, which means that it has been activated (fig. 28).





(symbol with sliding button) is shown in blue, which means that it has been activated (fig. 28).

Touching the "Settings" button (symbol with sliding button) displays the settings menu with five program phases: Freezing, Storage, Thawing, Proving, Holding (fig. 29).

Fig. 28

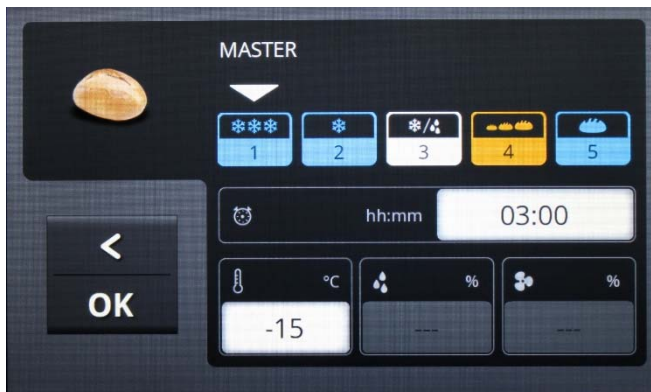
Fields are shown below that contain the values for duration, temperature and relative humidity for the respective program phase. By touching the field for the respective



program phase, for example , you select it to have its values set. The fields are then opened, for example



, by touching them (white fields). The data entry menu is shown, for example time, "Duration" (fig. 30).

Fig. 29



Fig. 30

In order to deactivate a program phase, the symbol must be selected, after which you press on it until the field "GREY" has been saved. In order to reactivate the program phase, you must press on it again, until the symbol has its original colour. If goods are placed in the unit that have been refrigerated in advance, and the program is started with storage, then under



you must choose selection, see the first section. For example, to disconnect holding you must make the same selection under . With "OK" the values are accepted and the menu closed. The selection menu "Save recipe ?" is then shown (fig. 31)





-  EXECUTE Saves the entered values temporarily and accordingly runs the execution of the program activated below only once.
-  SAVE Enables storage of the changes in a special user-defined program (see the section "User-defined programs", page 27).

Fig. 31



Means that the menu will be exited without changes, i.e. the changes will be rejected.

## Display during program execution (fig. 32)

The top line shows the phase of the program execution currently running depending upon the program selected:

Freezing, Storage, Thawing, Proving, Holding

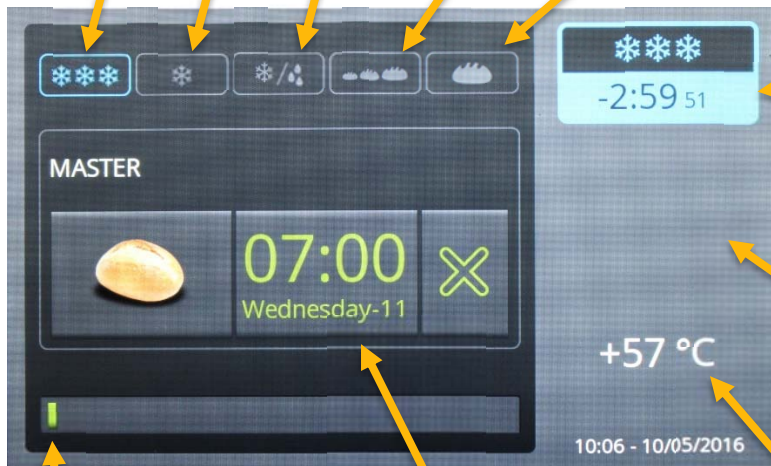

The field in the upper right rectangle shows the currently running program phase and the associated remaining (residual) time.

A red triangle is shown as an alarm symbol in the event of an alarm.

The green bar at the bottom of the display shows the total program execution in proportion to the duration.

In the window in the middle, the symbol for the currently running program is shown at the left, in the centre the ending time for the program and at the right a button to interrupt the program.

The current value for the temperature or the relative humidity is shown in the lower right corner depending upon the program phase.

## Changing a running program



Fig. 33

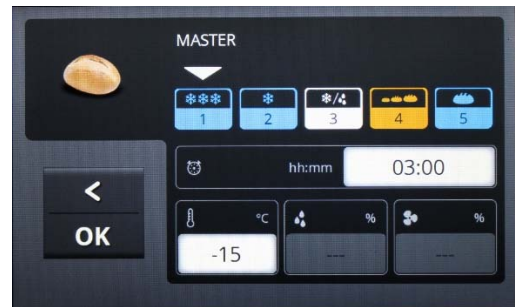

Fig. 34

Touching the program symbol (fig. 33) opens the settings menu (fig. 34), where you can change the specifications for program phases that have not been run yet.

Touching the field with the ending time for the program (fig. 35) opens the settings menus for date and time (fig. 36) for purposes of changing the ending time for the program, see the above for the descriptive section "Changing the ending time for the program" (page 22) / "Changing the date of the ending time for the program" (page 23).

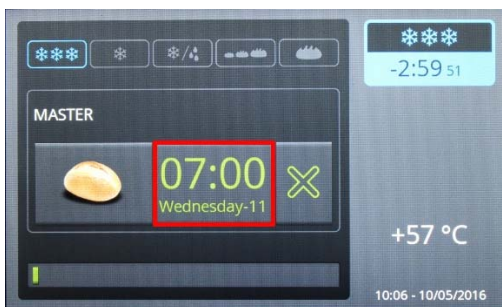

Fig. 20

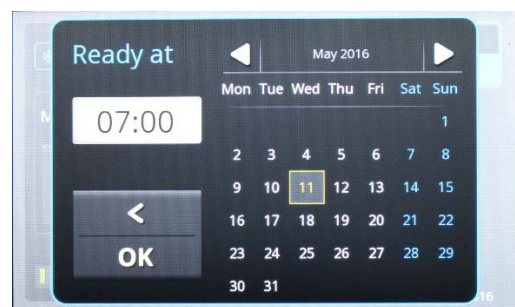

Fig. 35

Fig. 36



Here, the date can be changed by touching the date fields. Selection of the time can be opened by touching the time window, fig. 20. Here, the time can be entered and saved with "OK". Exit the menu without making changes with "<".

The ending time for the program may only be changed before the start of the thawing phase!

## Interruption of the currently running program

Touching the button  causes the currently running program to be interrupted (fig. 36).



Fig. 36

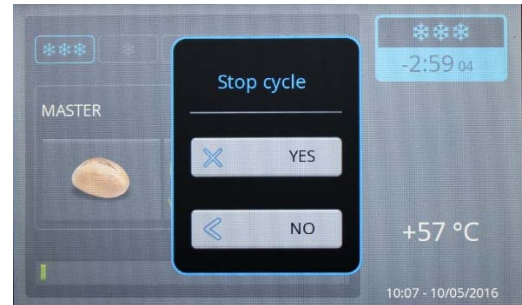



Fig. 37

A window opens where for verification purposes you are asked whether the program should really be halted (fig. 37). If  YES ("YES") is selected, the program is stopped. If  NO ("Back") is selected then interruption of the program is interrupted, i.e. you return to the currently running program without any action being taken.

## Storage of user-defined (own) programs

In order to change a predefined program and save it as your own program, touch the button on the keyboard with the symbol (here, for example, Master). The selected symbol is displayed with a blue edge, and the "Settings" button (symbol with sliding button) is shown in blue, which means that it has been activated (fig. 38). Touching the "Settings" button (symbol with sliding button) displays the settings menu with the five program phases (fig. 39).



Fig. 38

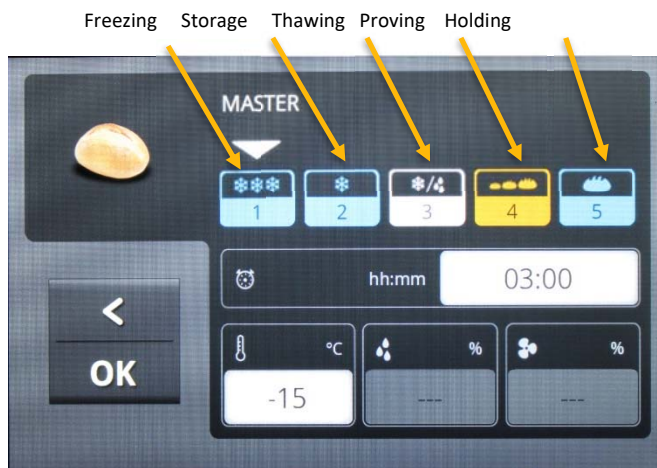



Fig. 39

Under these, there are fields containing the values for duration, temperature and relative humidity for the respective program phase. By touching the field for the respective program phase,  for example, it is selected for the setting of its values. Then the fields, for example , are opened when touched. The value entered for a value, for example the length of time "Duration", is shown (fig. 40).

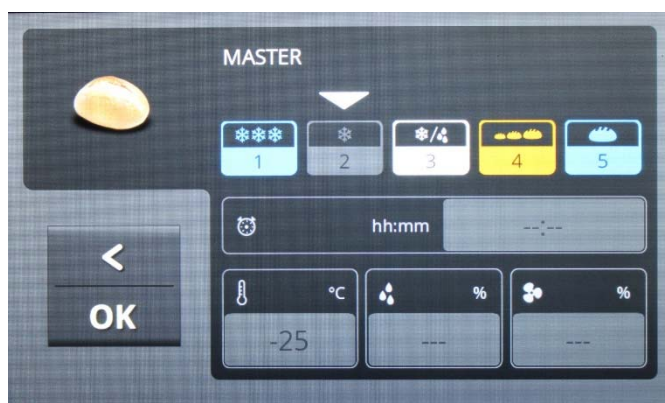





Fig. 40

In order to deactivate a program phase, the symbol must be selected, after which you press on it until the "GREY" field has been saved. To reactivate the program phase, you must press on it again until the symbol has its original colour. If goods are placed in the unit that have been refrigerated in advance, and the program is started with storage, then under  you must choose selection, see the first section. For example, to disconnect holding, you have to make the same selection under .

With "OK" the values are accepted and the menu closed. The selection menu "Save recipe ?" is then shown (fig. 41)



 EXECUTE Saves the entered values temporarily and runs in a corresponding manner the commenced program sequence 1 x.

 SAVE Means that the menu is exited without changes.

Fig. 41



With  CANCEL the settings made are saved in a special user-defined program. The storage menu is displayed.



Fig. 42



Fig. 43

When touching the field with the program name (fig. 42), a window with an alphanumeric keyboard is displayed for entry of a special program name (fig. 43). Enter a name for the program, and press "OK", or exit the window without changes with  .

The storage menu is then displayed again.



Fig. 43

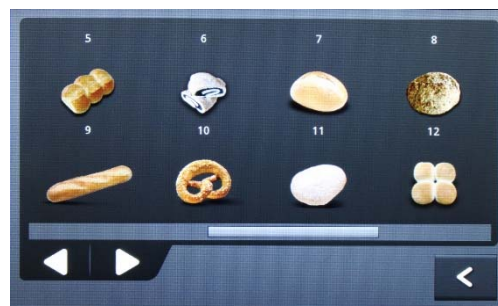



Fig. 44

Touching the program symbol (fig. 43) shows a selection of symbols for your own programs (fig. 44). Choose a symbol by touching it, and navigate back and forth between further

symbols with "<" or ">". Change for example the picture from  to  or exit the menu without changes with "<".

The storage menus will be displayed.



Fig. 45



Fig. 46





Touching the field  selects the memory location in one of the folders    in the start menu.



Fig. 47

Select a folder, or exit the menu without changes with "<".

Bear in mind that the preconfigured programs themselves in the folder  cannot be overwritten.

When all settings have been adjusted, you can save your program with "OK".

## Manual programs



The display start page (fig. 48) will save up to four different symbols. You can activate each one of these program phases separately to for example use the unit as a storage freezer or solely as a proving machine.

Fig. 48

Procedure at the start of the phases:

Select the desired program, and press once, until a blue frame is displayed.

Then press the symbol  at the bottom to the right, and set the settings accordingly (white fields).

Exit the menu with the symbol OK. For further steps in connection with execution, storage and interruption, please see page 29.

Exit the menu without saving with the button "<".

## Deletion of a specially created program

Select program, blue frame is displayed, after which you continue to press until a new menu item is displayed, (fig. 49).



Fig. 49

You can now select "YES" or "NO" for deletion. The program is deleted by selecting "YES", whereas it continues to be available by selecting "NO".

## Alarms/error messages



If an error arises, an error message window is displayed on the screen, for example a room sensor error, and an acoustic alarm is issued.

In order to acknowledge this alarm, you must touch the alarm window (the area with the black background).

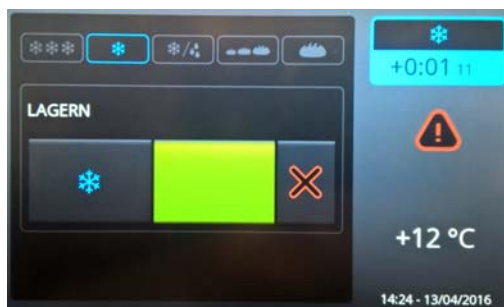

Then a red triangle is shown on the display for the currently executing program until the error is remedied.

Depending upon the priority of the error, the program will continue with an emergency program, or it will be interrupted.

## Temperature alarms

Code	Error message	Description	System reaction
E10	Alarm high temperature	The temperature around the room sensor has been above the alarm value for longer than the alarm delay time	none
E11	Alarm low temperature	The temperature around the room sensor has been below the alarm value for longer than the alarm delay time	none
E8	Condenser temperature high	The temperature around the evaporator sensor has been above the alarm value for longer than the alarm delay time	none
E7	Too many consecutive evaporator temperature alarms	The evaporator temperature alarm is occurring more frequently than the setting for repetition counts	The compressor is disconnected, and the evaporator fan runs with 100% power.

## Sensor alarms

Code	Error message	Description	System reaction
E0	Room sensor error	Sensor defective, not connected or short-circuited.	Compressor runs for 5 min. ON and 5 min. OFF.
E1	Evaporator sensor error	Sensor defective, not connected or short-circuited.	Defrosting will be 45 min., and the evaporator fan will start 10 min. after the defrosting.
E2	Condenser sensor error	Sensor defective, not connected or short-circuited	None
E6	RF sensor error	Sensor defective, not connected or short-circuited	Vapour system will be shut off until the error has been remedied

## Vapour system alarms

Code	Error message	Description	System reaction
E9	Boiler overfilled – summon service	Too much water in boiler, defective water valve.	Vapour system will be shut off until the error has been remedied.
E13	Water connection error	No water connection to boiler, no power to water valve.	No steam production
E14, E32	Test water connection	No water connection to boiler, no power to water valve.	No steam production
E33	Boiler discharge error	Defective water valve.	Vapour system will be shut off until the error has been remedied.
E34	Boiler overfilled	Defective water valve	Vapour system will be shut off until the error has been remedied.

## Other alarms

Code	Error message	Description	System reaction
E12	Door open	Door open longer than 45 min. or defective door contact.	Compressor disconnected until the error has been remedied.
E35	Power connection error	Loss of power for more than 5 min.	Program is shut down when the power comes back on again.

# Alarm log

Alarms are stored in the alarm list.

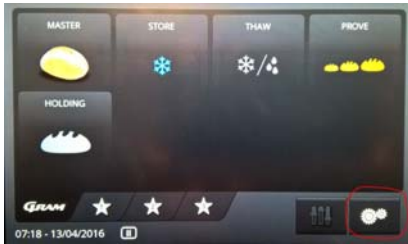

To open the alarm list, first push „Settings“  ...



and then push "Alarm" .



During operation, the alarm list can be accessed by pressing the area of the alarm symbol on the right edge of the picture (marked red in the picture)

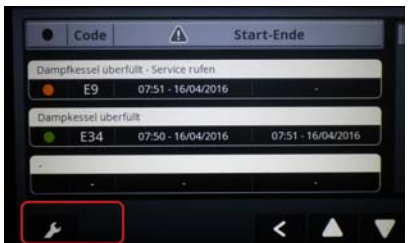

The last 20 alarms are displayed.

By touching the "Maintenance" button , you can enter the menu for deleting the alarm entries and counter headers.

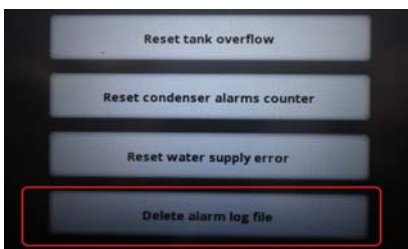



With the button "Delete alarm log file", the list is deleted...

## Info I/O: Switching states and sensor values

The current values of the sensors and the switching states of the controller outputs can be displayed in the menu „Info I/O“.



To display the „Info I/O“ menu, first push the “Settings”  button and then the “Info”  button.





During operation, the Info window can be accessed by pressing the area of the temperature/humidity symbol on the right edge of the picture (marked red in the picture)

## TEST: Manual switching of the components

The outputs of the electronic controller can be switched manually for test purposes. When a button is touched, it appears blue, the output is switched on. Press again to turn off.

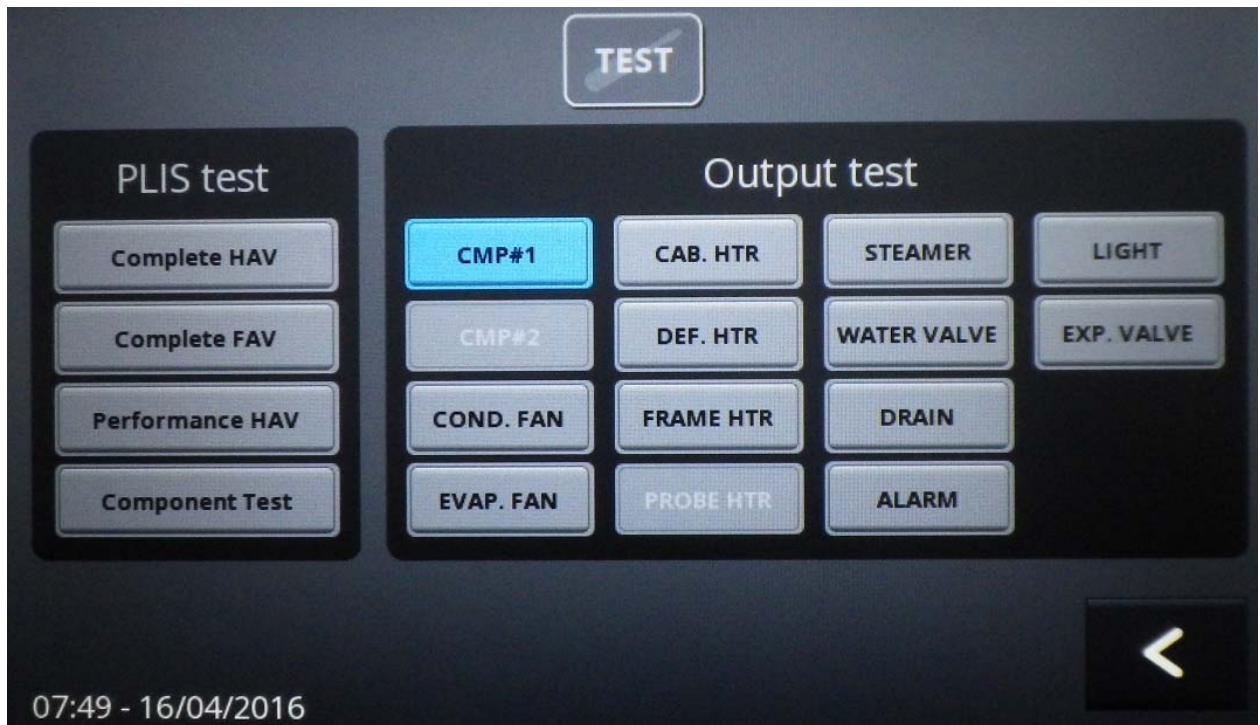

To display the Test menu, first push the "Settings"  button and then the "TEST"  button.



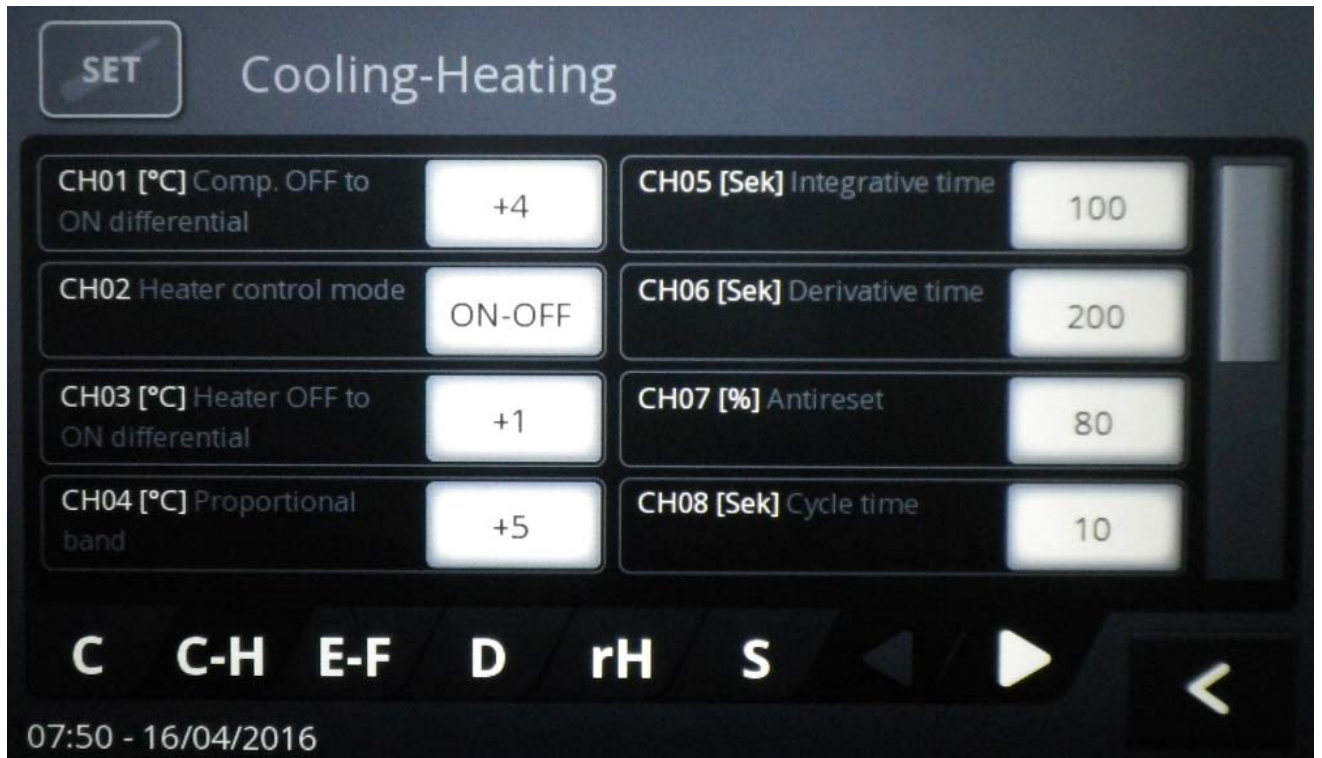

## SET: Service parameters

The parameters are listed in several pages of the "SET" menu.







To display the list, first push the “Settings”  button and then the “SET”  button.

Navigation between pages is done by touching the corresponding tabs at the bottom edge:



- C = Cooling
- C-H = Cooling/Heating
- E-F = Evaporator Fan
- D = Defrost
- rH = relative Humidity
- S = System parameter
- A = Alarm parameter
- I = Input
- N = Network parameter (not used)



Touching the white buttons with the entries opens an input window. Here the values are edited and saved with  or leave the menu without changes with .

## Parameter list

Item	<u>COOLING</u>	Min	Max	Def	Dim.	Lev	Note
<b>C01</b>	Minimum compressor on time	0	60	2	min	serv	
<b>C02</b>	Minimum compressor off time	0	60	5	min	serv	
<b>C03</b>	Compressor ON->OFF differential - FREEZE, STORAGE, RETARD-	0,0	10,0	2,0	°K	serv	Troom <= SP - C03 ==> compressor OFF
<b>C04</b>	Compressor OFF->ON differential - FREEZE, STORAGE, RETARD-	0,0	10,0	2,0	°K	serv	Troom >= SP + C04 ==> compressor ON
<b>C05</b>	Diff. between room set point and evaporator temp. to allow compressor cut in	0,0	30,0	5,0	°K	serv	Tevap <= SP - C05 ==> compressor cut in not allowed
<b>C06</b>	Compressor run when Troom is faulty - FREEZE-	0	30	10	min	serv	C06=0 ==> compressor always OFF; C07=0 and C06>0 ==> compressor always ON;
<b>C07</b>	Compressor stop when Troom is faulty - FREEZE-	0	30	2	min	serv	C06=4, C07=6: the compressor will cycle 4 minutes ON and 6 minutes OFF;
<b>C08</b>	Compressor run when Troom is faulty - STORAGE, RETARD-	0	30	5	min	serv	
<b>C09</b>	Compressor stop when Troom is faulty - STORAGE, RETARD-	0	30	5	min	serv	
Item	<u>COOLING / HEATING-</u>	Min	Max	Def	Dim.	Lev	Note
<b>CH01</b>	Compressor OFF->ON differential	0,0	10,0	4,0	°K	serv	T room >= SP + CH01 ==> compressor ON; T room <= SP ==> compressor OFF
<b>CH02</b>	Heater control mode	ON-OFF	PID	ON-OFF		serv	
<b>CH03</b>	Heater OFF->ON differential	0,0	10,0	1,0	°K	serv	T room <= SP - CH02 ==> heater ON; T room >= SP ==> heater OFF
<b>CH04</b>	Proportional band	1,0	30,0	5,0	°C	serv	
<b>CH05</b>	Integrative time	0	600	100	s	serv	
<b>CH06</b>	Derivative time	0	600	200	s	serv	
<b>CH07</b>	Antireset	0	100	80	%	serv	
<b>CH08</b>	Cycle time	1	300	10	s	serv	Tevap >= SP + CH07 ==> heater cut in not allowed
<b>CH09</b>	Minimum time between heater off and compressor on	0	20	2	min	serv	
<b>CH10</b>	Minimum time between compressor off and heater on	0	20	2	min	serv	
<b>CH11</b>	Diff. between room set point and evaporator temp. to allow heater cut in	0,0	30,0	7,0	°K	serv	Tevap >= SP + CH07 ==> heater cut in not allowed
<b>CH12</b>	Allow the use of the defrost heater as additional cabinet heater	NO	YES	YES		serv	

Item	<u>EVAPORATOR FAN</u>	Min	Max	Def	Dim.	Lev	Note
<b>F01</b>	Evaporator fan speed, compressor, heater and steamer OFF -FREEZE-	5	100	100	%	serv	
<b>F02</b>	Evaporator fan speed, compressor, heater and steamer OFF -STORAGE-	5	100	50	%	serv	
<b>F03</b>	Evaporator fan speed, compressor, heater and steamer OFF -THAW-	5	100	50	%	serv	
<b>F04</b>	Evaporator fan speed, compressor, heater and steamer OFF -PROVE-	5	100	30	%	serv	
<b>F05</b>	Evaporator fan speed, compressor, heater and steamer OFF -RETARD-	5	100	50	%	serv	
Item	<u>DEFROST -STORAGE-</u>	Min	Max	Def	Dim.	Lev	Note
<b>D01</b>	Defrost enable	NO	YES	YES		serv	
<b>D02</b>	Defrost start mode in storage	TIMED, REAL TIME		REAL TIME		serv	
<b>D03</b>	Time interval among defrosts	0	24	6	hrs	user	
<b>D04</b>	Scheduled time for defrost 1	0	23:59	--:--		user	
<b>D05</b>	Scheduled time for defrost 2	0	23:59	--:--		user	
<b>D06</b>	Scheduled time for defrost 3	0	23:59	--:--		user	
<b>D07</b>	Scheduled time for defrost 4	0	23:59	--:--		user	
<b>D08</b>	Defrost end temperature	5,0	25,0	15,0	°C	serv	
<b>D09</b>	Maximum duration of defrost	1	100	45	min	serv	
<b>D10</b>	Defrost type	OFF, ELECTRIC, HOT GAS		ELECTRIC		serv	
<b>D11</b>	Dripping time	0	10	2	min	serv	
<b>D12</b>	Fan in defrost	NO	YES	NO		serv	
<b>D13</b>	Evaporator fan speed in defrost	20	100	50	%	serv	
<b>D14</b>	Evaporator fan re-start temperature after defrost	-10,0	10,0	0	°C	serv	
<b>D15</b>	Maximum evaporator fan stop after defrost	0	120	10	min	serv	
<b>D16</b>	Defrost with evaporator probe fail	NO	YES	YES		serv	
<b>D17</b>	Defrost performed setpoint	0,0	15,0	5,0	°C	serv	Enabled only for timed defrost: if Tevaporator stay above "defrost performed setpoint" for "defrost performed" minutes, defrost is considered performed (timer counter is reset).
<b>D18</b>	Defrost performed duration	0	60	15	min	serv	

Item	STEAMER	Min	Max	Def	Dim.	Lev	Note
H01	Humidity control	NO	YES	YES		serv	
H01	Humidity control	NO	YES	YES		serv	
H02	Set temperature above which the boiler can be activated	-5,0	15,0	5,0	°C	serv	
H03	Use external SSR	NO	YES	YES		serv	
H04	Max allowed current in boiler (Imax2)	0,5	3,5 / 7,5	6,5	A	serv	
H05	Current in boiler to close the water inlet valve (Imax1)	0,5	3,5 / 7,5	2,3	A	serv	
H06	Current in boiler to open the water inlet valve (Imin)	0,5	3,5 / 7,5	2,0	A	serv	
H07	Max water inlet time	1	180	60	s	serv	
H08	Number of (H07) to elaps without resulting in (H05) being reached, before check water supply warning	1	5	2		serv	
H09	Number of (H07) to elaps without resulting in (H05) being reached, before setting boiler alarm	1	5	5		serv	
H10	Number of over flow detections to stop the boiler operation until a service reset	0	5	5		serv	
H11	Boiler check performed at the beginning of every proces including steam	NO	YES	NO		serv	
H12	Total drain time for boiler	1	120	30	s	serv	
H13	Drain time if H04 is reached	1	30	1	s	serv	
H14	Total drain of boiler (H12) is performed at least every X day	0	8	3		serv	
H15	Number of tank load to perform a total drain (at the end of a recipe execution)	1	10	5		serv	
H16	Steam production ON -> OFF differential	0	10	0	%	serv	
H17	Steam production OFF -> ON differential	0	10	2	%	serv	
H18	Delay for water inlet	0	60	5	s	serv	

Item	SYSTEM	Min	Max	Def	Dim.	Lev	Note
S01	Plateau time -THAW-	0	100	25	%	user	
S02	Plateau time -PROVE-	0	100	25	%	user	
S03	Starting point acquisition time	10	180	60	s	serv	for slope calculation
S04	Frame heaters setpoint	-30,0	30,0	-5,0	°C	serv	
S05	Frame heaters differential	0,0	10,0	5,0	°K	serv	
S06	Door switch	NONE, NO, NC		NO		operator	No door switch; Normally Open; Normally Closed
S07	Door open shutdown delay	1	60	1	min	serv	After this time the compressor, heater and boiler are cut off
S08	Door open timeout	0	180	45	min	serv	After this time the controller resumes the regulation as per door closed (0 ==> disabled)
S09	Maximum time lights ON	1	30	5	min	serv	
S10	Daylight saving time	NO, YES, AUTO		AUTO		user	YES = manual, AUTO = europe
S11	Power Fail max duration	0	60	5	min	serv	0 => disabled
S12	Buzzer sounds at recipe completion	0	600	20	s	serv	0 => buzzer doesn't sound
S13	Modbus address	1	250	1			
S14	Performance test setpoint	-25,0	50,0	-18,0	°C		
S15	Performance test duration	1	60	30	min		
S16	Component test duration	1	300	30	s		
S17	Component test pause	1	300	5	s		
S18	Boiler test: current setpoint	0,5	3,5	2,0	A		
S19	Boiler test: overflow timeout	1	10	5	min		
S20	Level II password	0	9999	2222	min		
Item	ALARM	Min	Max	Def	Dim.	Lev	Note
A01	Low temperature alarm differential - STORAGE, RETARD, plateau time THAW, plateau time PROVE-	-20,0	0,0	-10,0	°K	serv	0 => low temp. Alarm disabled
A02	High temperature alarm differential - STORAGE, RETARD, plateau time THAW, plateau time PROVE-	0,0	20,0	10,0	°K	serv	0 => high temp. Alarm disabled
A03	Delay before alarm temperature warning	1	240	120	min	serv	
A04	Condensation temperature alarm set	0,0	100,0	65,0	°C	serv	Tcondenser1 >= S14 ==> high condenser temperature alarm set
A05	Condensation temperature alarm reset	0,0	100,0	40,0	°C	serv	Tcondenser1 <= S15 ==> high condenser temperature alarm reset
A06	Operation in case of high condenser alarm	NON, ALARM, STOP		STOP		serv	Compressor OFF, condenser fan ON
A07	Max consecutive high condenser temp alarms before setting an alarm	0	10	5		serv	only active if S16 = STOP; 0 = disabled

Item	<u>INPUT</u>	Min	Max	Def	Dim.	Lev	Note
<b>I01</b>	Adjusting room sensor input	-5,0	5,0	0,0	°K	serv	
<b>I02</b>	Adjusting evaporator sensor input	-5,0	5,0	0,0	°K	serv	
<b>I03</b>	Adjusting condenser 1 sensor input	-5,0	5,0	0,0	°K	serv	
<b>I04</b>	Adjusting Humidity sensor input	-5	5	0	%	serv	
Item	<u>NETWORK</u>	Min	Max	Def	Dim.	Lev	Note
<b>N01</b>	IPaddr - 1	1	255	192		user	
<b>N02</b>	IPaddr - 2	1	255	168		user	
<b>N03</b>	IPaddr - 3	1	255	0		user	
<b>N04</b>	IPaddr - 4	1	255	27		user	
<b>N05</b>	Subnet mask - 1	1	255	255		user	
<b>N06</b>	Subnet mask - 2	1	255	255		user	
<b>N07</b>	Subnet mask - 3	1	255	255		user	
<b>N08</b>	Subnet mask - 4	1	255	0		user	

## Defrosting intervals (Storage)

The defrost intervals or time points are set in the "SET" menu, "D" (= defrost) tab, see above parameter list.

Item	<u>DEFROST-STORAGE-</u>	Min	Max	Def	Dim.	Lev	Note
<b>D03</b>	Time interval among defrosts	0	24	6	hrs	user	
<b>D04</b>	Scheduled time for defrost 1	0	23:59 , --:--	--:--		user	
<b>D05</b>	Scheduled time for defrost 2	0	23:59 , --:--	--:--		user	
<b>D06</b>	Scheduled time for defrost 3	0	23:59 , --:--	--:--		user	
<b>D07</b>	Scheduled time for defrost 4	0	23:59 , --:--	--:--		user	

## Entering the serviceparameters, level III



The change of the service parameters requires the registration to level "III" as Gram Service. The input window is reached by pressing the "Service"  button. Touching the input field opens a numerical keypad. The service password is "6500". After completion of the work, please log out! Logging off is done automatically when the device is disconnected from the power supply.

## Entering level II as authorized user (owner)



Reading the info window and changing the user settings requires logging in as an authorized user. The input window is reached by pressing the "Service" button. Touching the input field opens a numerical keypad. The service password is "2222". When the device is disconnected from the power supply, the device automatically returns to level I (= personnel, unauthorized user).

## Maintenance of the steam humidifier system

The operating characteristics and maintenance intervals of the steam humidifier are mainly dependent on the existing water quality (total hardness, conductivity) and the amount of steam generated since the last maintenance. Different qualities can lengthen or shorten the period. The residues found in the steam cylinder provide an indication of future maintenance intervals.

### Flushing the steam cylinder

The steam cylinder can be flushed by turning the cabinet off and then on again. Furthermore the system conducts a flushing regularly, dependent on the water quality.

### Servicing:

Servicing of the steam humidifier system should be done with the following intervals:

4 weeks after commissioning (with normal water quality):

- Visual inspection of electrical and mechanical components, cables, connections, etc.
- Removal of scale from cylinder, water outlet hose and drain pump.
- Inspection of electrodes.

Every 6 months (with normal water quality):

- Visual inspection of electrical and mechanical components, cables, connections, etc.
- Removal of scale from cylinder, water outlet hose and drain pump.
- Inspection of electrodes.

## Cleaning the steam cylinder



Disconnect the cabinet at the mains.

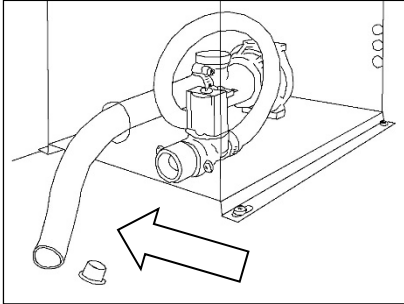

Empty the cylinder of water. Pull out the yellow plug of the drain hose. Bend the hose down behind the cabinet back, so that the water can be emptied into a bucket or drain. Place the plug in the hose and put the hose in place again.



Be aware that the water from the cylinder might be very hot!

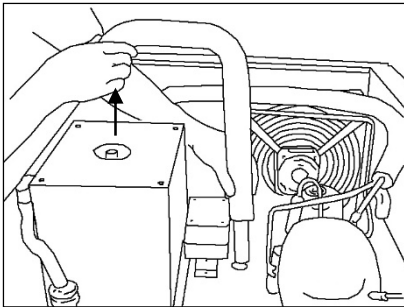

Dismount the steam pipe.

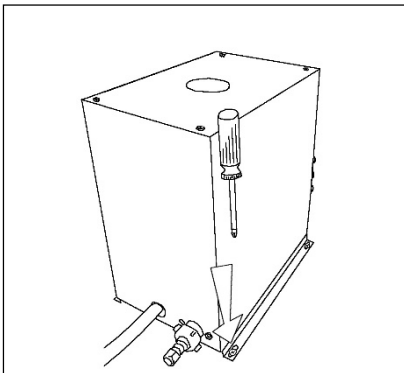

Dismantle the steam cylinder cover. Hoses and electrical connections should be disconnected. Lift the cylinder off the base. Open the cylinder by releasing the flange clamps.

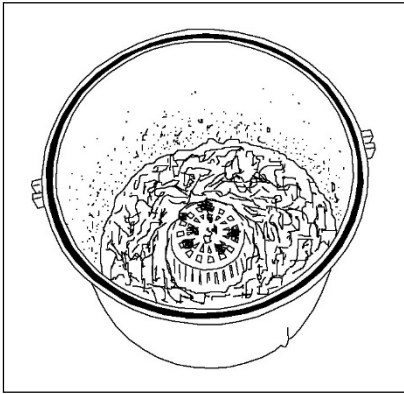

Remove all scale and sludge from cylinder



When cleaning do not use acids or other chemicals.

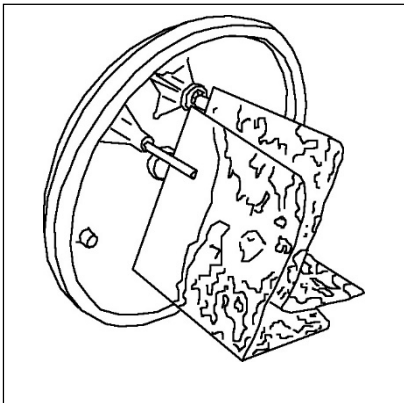

Remove deposit from the heating electrodes by knocking them (small amounts that remain are acceptable).

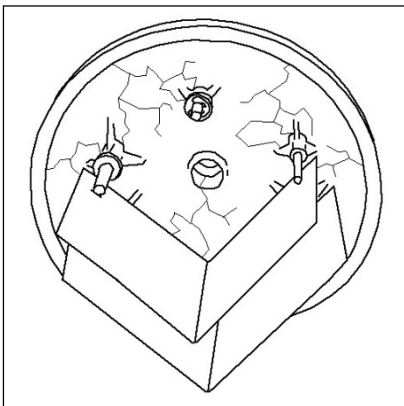

Inspect the inside of the top part of the cylinder for furring and any electrical bridging (black grooves) between the electrodes and their bushings and remove completely by washing.



Top half of the cylinder must be replaced if electrical bridges have penetrated deeply into the material.

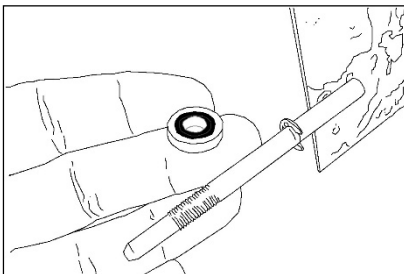

Examine the electrode bushings, and clean them if necessary. Be aware that the rubber seal should face the top of the cylinder.

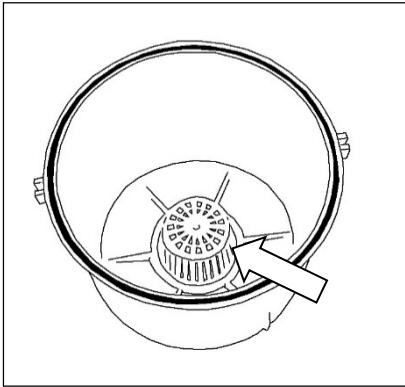

Clean cylinder coarse strainer.

Assembling the cylinder:

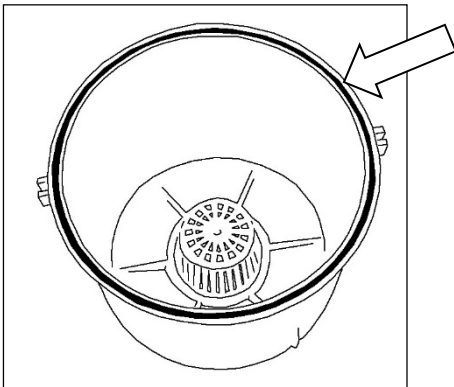

If necessary, replace the o-ring seal between the top and bottom part.

Connect upper and lower parts with clamps.

Replace the o-ring seal in the bottom of the cylinder, if necessary.

Refit cylinder firmly into the base.

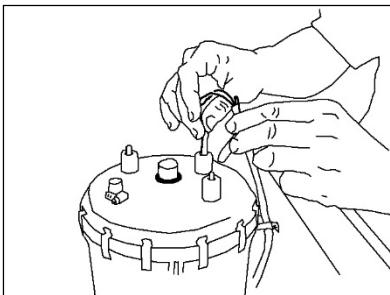

Connect plugs to the matching electrodes and level sensor.

Connect hoses for water supply and drain.

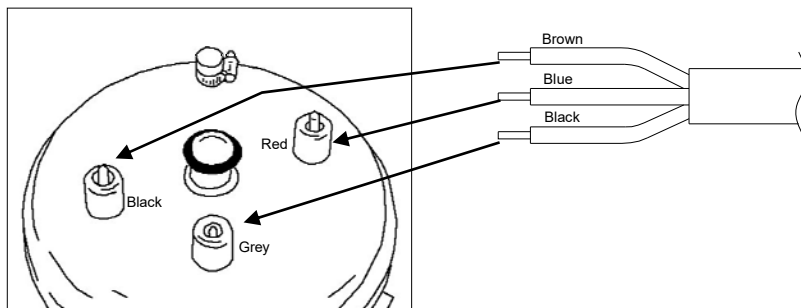

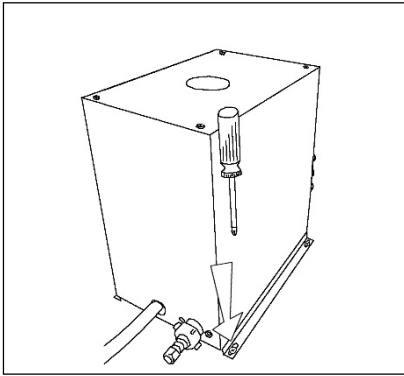

Refit the cylinder cover.

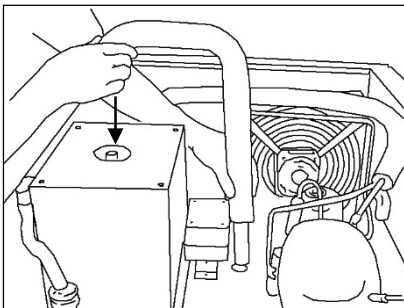

Refit the steam pipe.

Switch on the unit and operate for 15 to 30 minutes. Check for any leaks.

#### Replacing electrodes

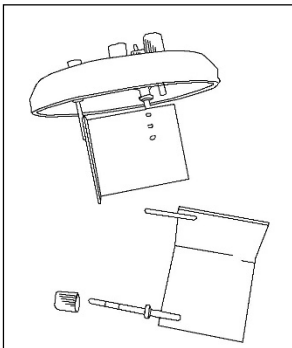

Disassemble the cylinder and open as described in chapter "Cleaning the steam cylinder".  
Loosen hand nuts and take out old electrodes.

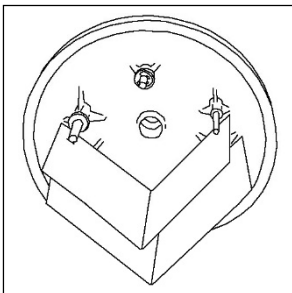

Insert new electrodes and fasten hand nuts – by hand only.

Reassemble the steam cylinder and fit as described in the chapter "Cleaning the steam cylinder".

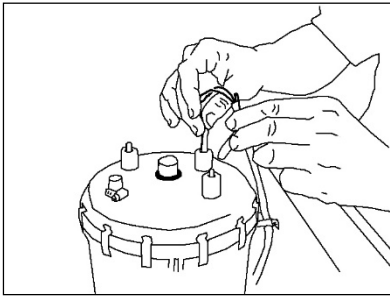

Connect plugs to the matching electrodes and level sensor.  
Connect hoses for water supply and drain.

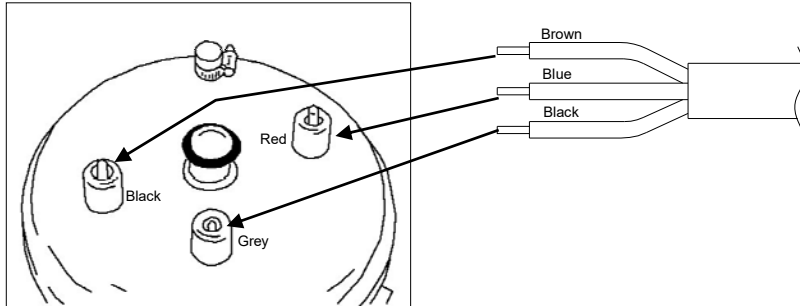

Switch on the unit and operate for 15 to 30 minutes. Check for any leaks.

### Cleaning the pump

Disassemble the cylinder and open as described in chapter "Cleaning the steam cylinder".

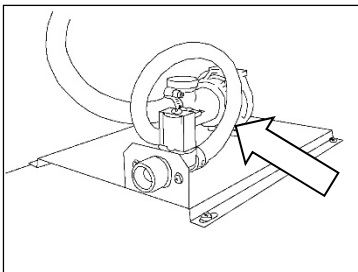

Remove electric cable from pump.  
Disconnect the hoses from the pump.

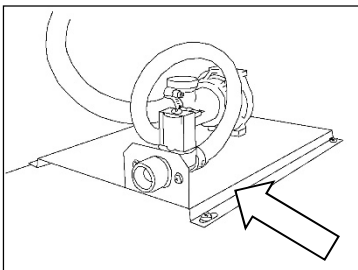

Dismount the base plate.  
Dismount the pump from the plate.

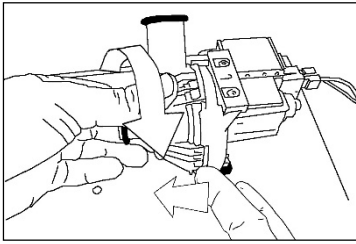

Open pump (bajonet joint).  
Remove residues from discharge hoses and pump.  
Replace o-ring as necessary.  
Reassemble the pump.

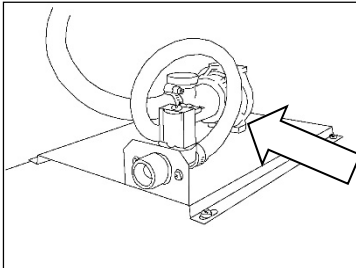

Mount the pump at the base plate.  
Connect the hoses to the pump.  
Connect electrical cable to pump.

Reassemble the steam cylinder and fit as described in the chapter "Cleaning the steam cylinder".  
Switch on the unit and operate for 15 to 30 minutes. Check for any leaks.

#### Cleaning the solenoid valve and filter

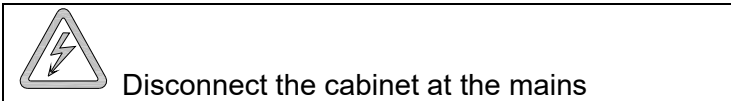

Disconnect the cabinet at the mains

Dismount the steam pipe and the cover as described in: "Cleaning the steam cylinder".

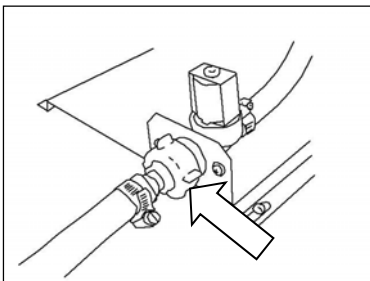

Shut off the water supply, and loosen the water connector.

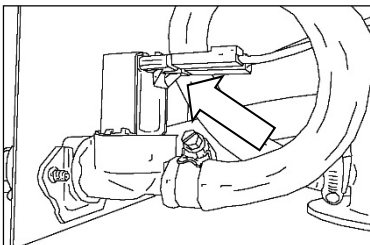

Remove the connectors for the solenoid valve.

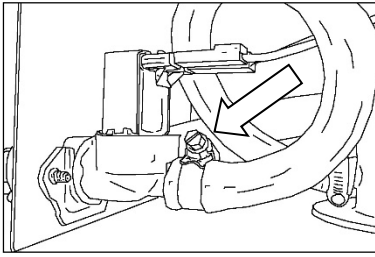

Remove the water supply hose by loosening the hose clip.

Dismount the solenoid valve from the bracket.

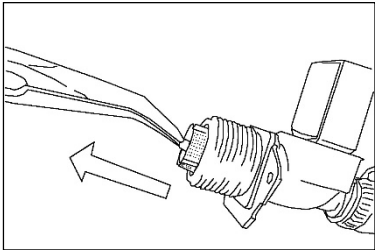

Disassemble the solenoid valve, and remove filter and reducer. Clean the parts.

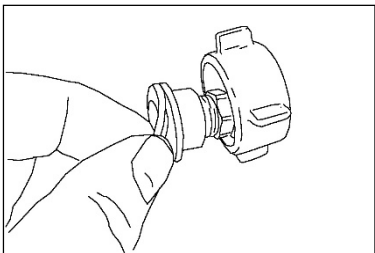

If necessary, replace the rubber seal.

Assemble the solenoid valve with filter and reducer again.

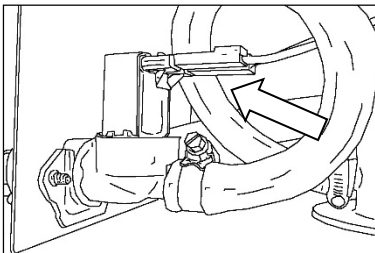

Mount the valve at the bracket and put on the connectors.

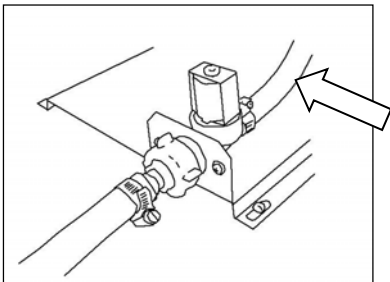

Put on the water supply hose again.

Mount the steam pipe and the cover again as described in: "Cleaning the steam cylinder".

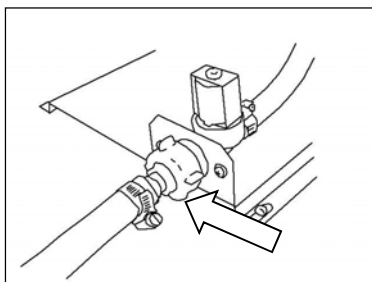

Connect the water supply again, and check for leaks.



# Piping diagram

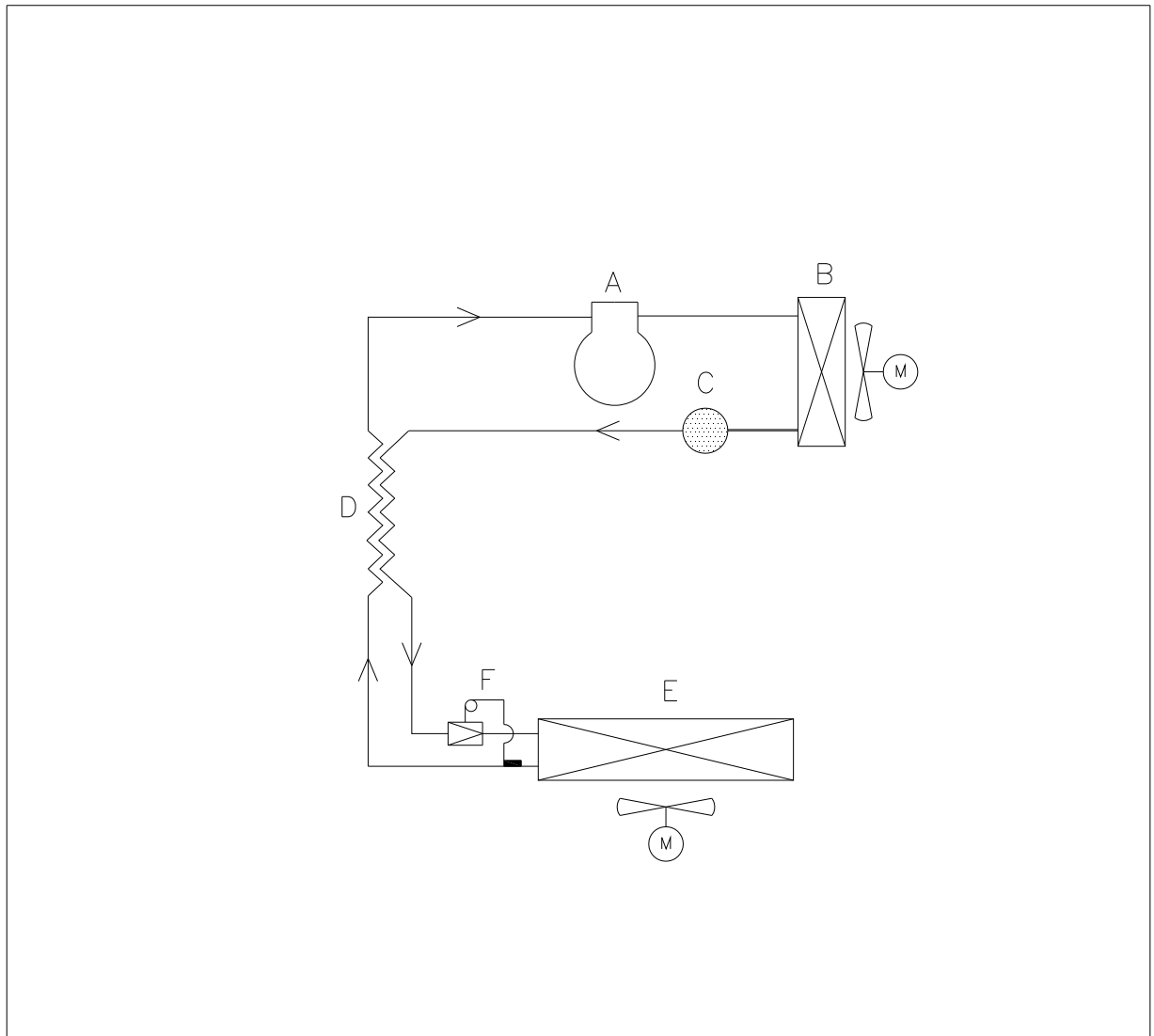

	DK	GB	D
A	Kompressor	Compressor	Kompressor
B	Kondensator	Condenser	Verflüssiger
C	Tørrefilter	Filter drier	Trockenfilter
D	Varmeudveksler	Heat exchanger	Wärmeaustauscher
E	Fordamper	Evaporator	Verdampfer
F	Ekspansionsventil	Expansion valve	Ekspansionsventil