

MULTIDECK WITH GLASS DOOR SERVICE MANUAL



**As the user, please use the operating instructions.
This service manual does not include operating instructions.
It is only intended for the service technician.
here.**

Content

1) Safety Information	3
2) Intended Use	3
3) Suitable Installation Site	3
4) Setting up Several Cabinets Side by Side	5
5) Unpacking and Installing the Cabinet	6
6) Condensation Water Re-evaporation.....	8
7) Electrical Connection.....	9
8) Instructions for Daily Use.....	10
9) Cleaning and Maintenance	11
10) Control Elements	13
Parameter List	19
11) Glass Door and Led Light Assembl	22
12) Measures for Taking the Cabinet out of Operation for Long Periods.....	24
13) Disposal	25
14) Technical Data	26
15) Dimensions	27
16) Wiring Diagram.....	39
17) Cooling Diagram.....	41

1) Safety Information

This service manual does not include comprehensive operating instructions for the user; it is only a further supplement to the operating instructions.

It intends for a trained service technician. As a result, many important safety instructions for the user are missing about the scope and readability. In case of doubt, please observe the information in the operating instructions for transport, installation, operation, and electrical safety and never pass on this service manual in place of the operating instructions.

2) Intended Use

This cabinet is intended for the display of packaged foods at a constant temperature. This cabinet mustn't be used to cool down or freeze foods.

Area of application:

Climate Class	Ambient Temperatures and Humidity
3	+25°C with %60 RH

3) Suitable Installation Site

The cabinet must be installed in a dry, well-ventilated room away from direct sunlight at a sufficient distance from radiators and other sources of heat. Please always consider the waste heat of all cabinets installed in one room!

The ambient temperature must lie between a minimum of **+16 °C** and a maximum of **+ 25°C**. A gap of at least 50 cm must be kept between the top edge of the machine compartment and the ceiling. The air exchange in this area must not be obstructed from the front or the side by screens etc. hanging from the ceiling.

For electrical safety reasons, the cabinet must not be operated outside. The refrigeration technology of the cabinet does not function outside or in unheated rooms (particularly in colder seasons) and can be damaged by low temperatures.

Distance from walls and ceiling:



A gap of at least 500 mm must be kept between the top edge of the machine compartment and the ceiling, and of at least 100 mm rear wall and 50 mm from walls, furniture and other cabinets.

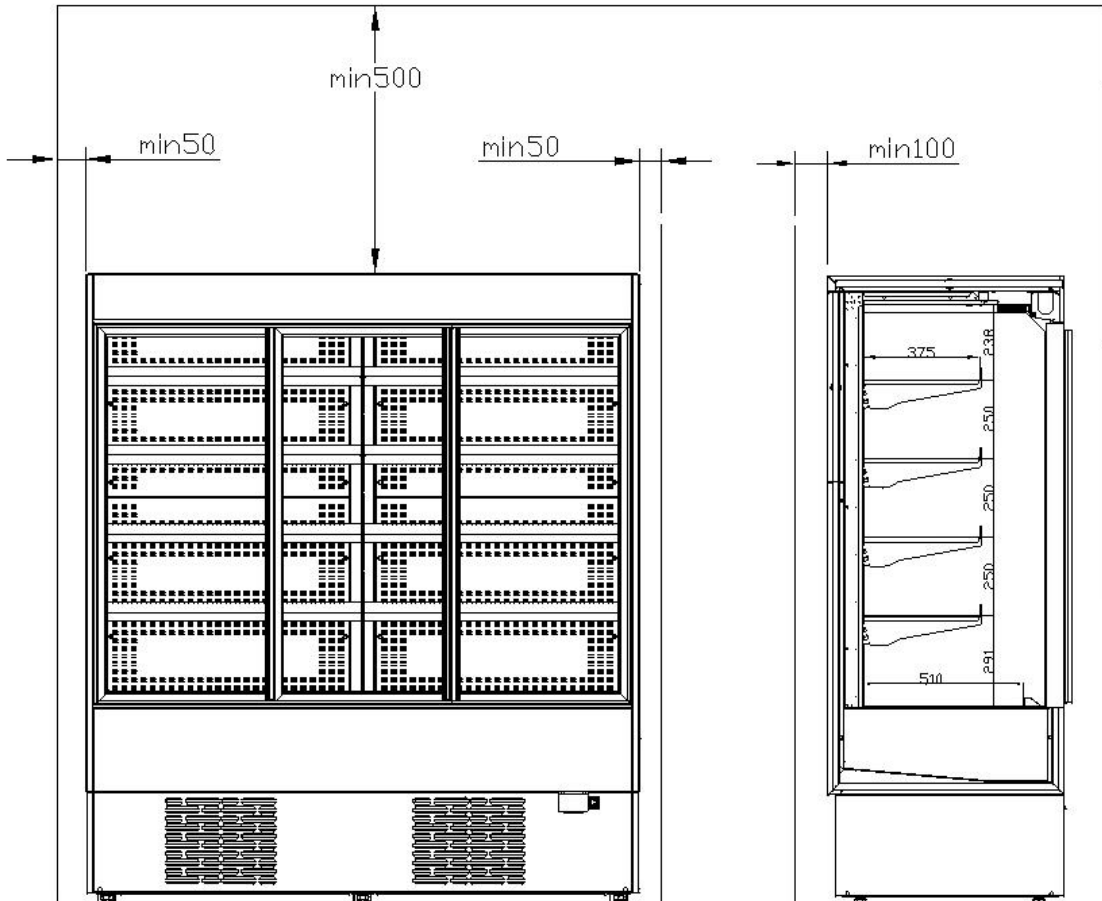

4) Setting up Several Cabinets Side by Side

Depending on the temperature and air humidity at the installation site as well as , the moisture in the ambient air can condense on the surface of a refrigerating unit due to its design. Condensation may occur on the device under conditions other than 25 °C and 60% relative humidity.

If several cooling or refrigeration units are set up side by side, this condensation effect becomes stronger, and a lower air quantity can circulate between the cabinets. As a result, a minimum distance of **30 to 50 mm** must be kept between the cabinets depending on the temperature and air humidity.

These gaps must not be sealed either at the top or bottom, but can be covered by a stainless-steel panel from the front for aesthetic purposes. The panel must be removable for cleaning within the gaps.

If it is not possible for air to circulate freely at the bottom, e.g. due to a base installation, then the gaps cannot be sealed at the front.

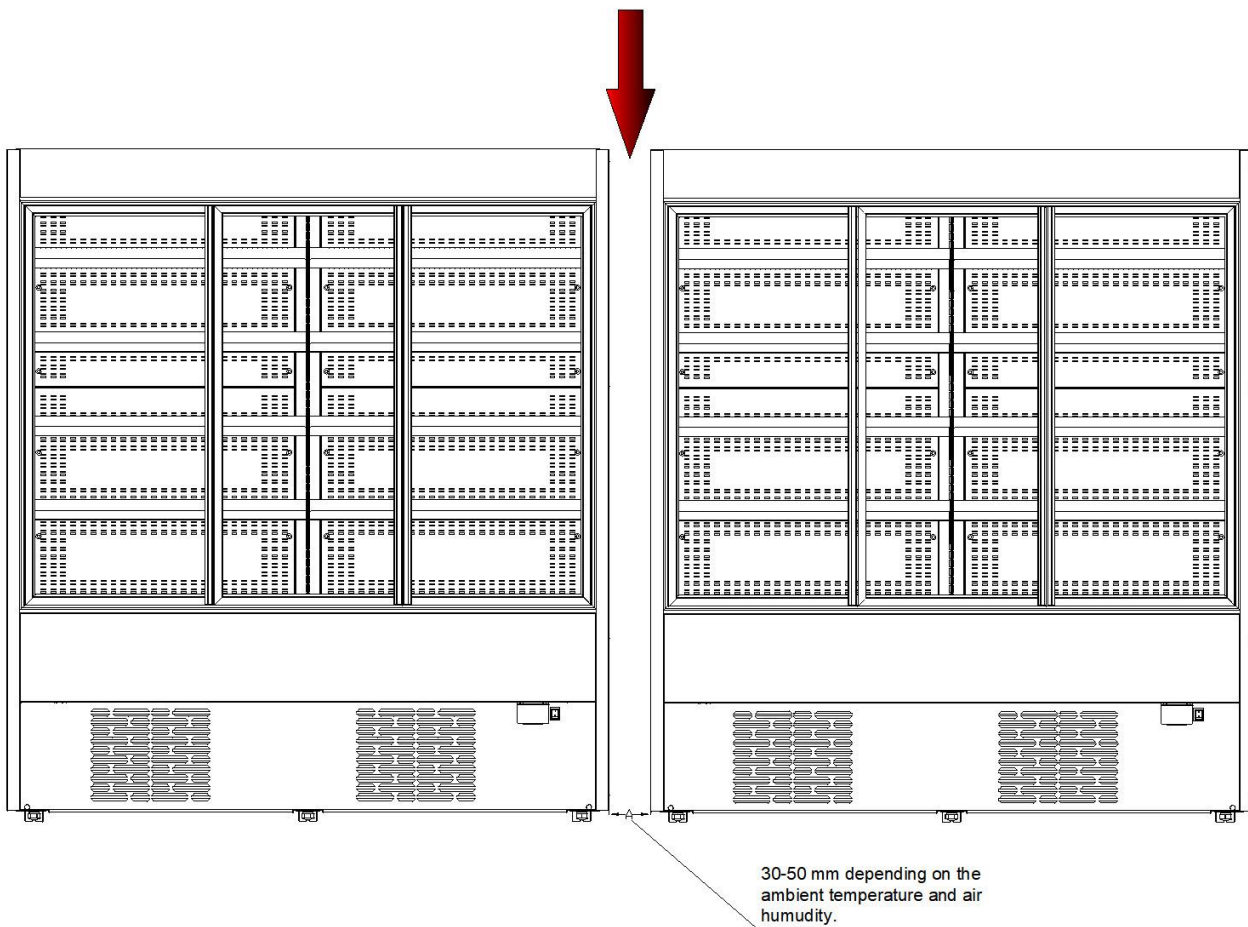

5) Unpacking and Installing the Cabinet



Warning The refrigeration unit is located at the under of the cabinet. At least four people are required to lay down the cabinet and set it up right again.



Important If the cabinet has laid on its back or was transported horizontally, then it must stand upright for at least two hours before switching it on to allow the oil to collect in the compressor.

Once the cabinet is on its back, the transport pallet must be removed by the following order;

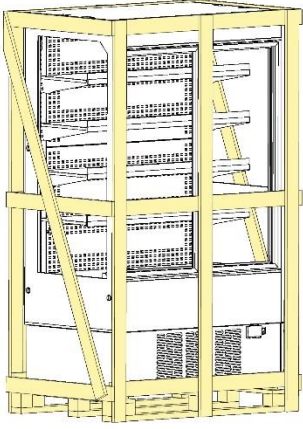
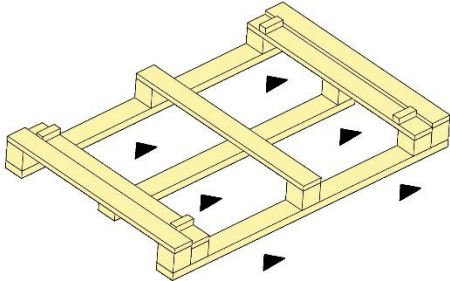
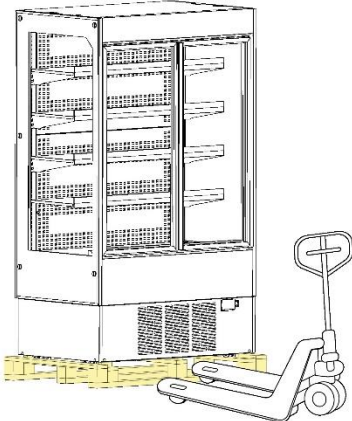
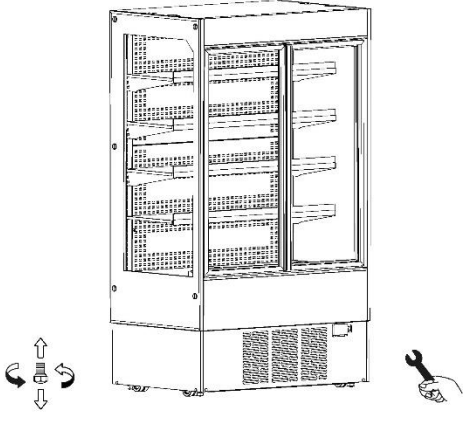
	
<p>1-Remove all outer packaging.</p>	<p>2-Use the indicated gaps for transportation and shipment.</p>
	
<p>3-Use the indicated gaps to unload from the pallet. Center the pallet truck and push it. Lift the device. Pull the pallet truck back. Lower the device to the desired location.</p>	<p>4-Adjust the level of the swivel feet. (The device should not remain on the wheels.)</p>

Moving and Levelling,

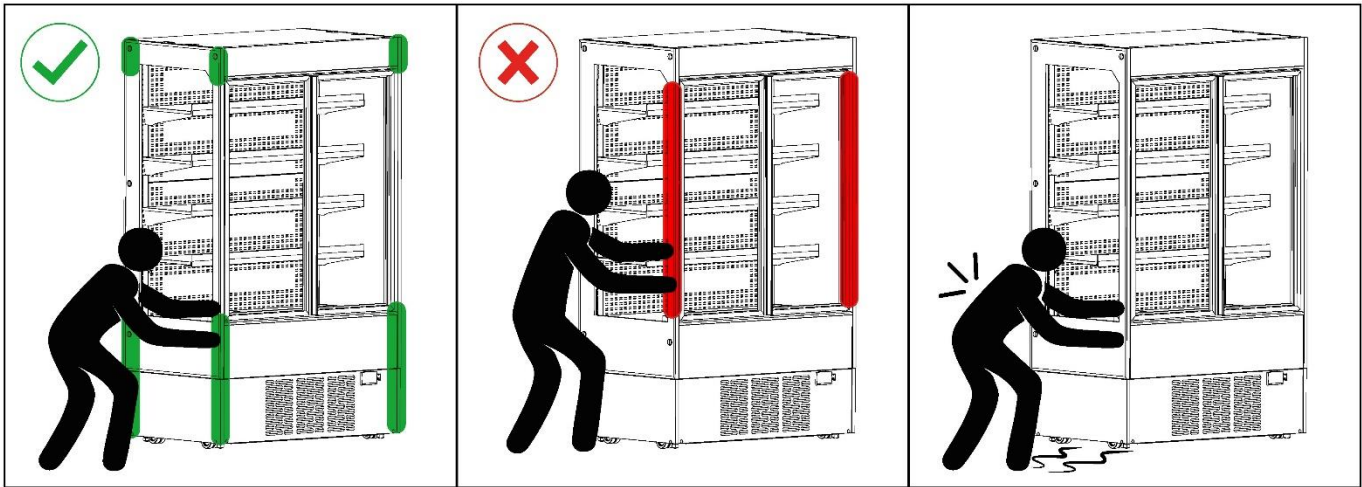

1

2

3

- 1- Two people should push the device in the desired direction on the floor. The device should be empty.
- 2- The device should not be pushed from the marked areas in the image.
- 3- Move the device easily on the rotating feet. Place the device in the desired location.



Important

Before performing these operations, cut off the energy.

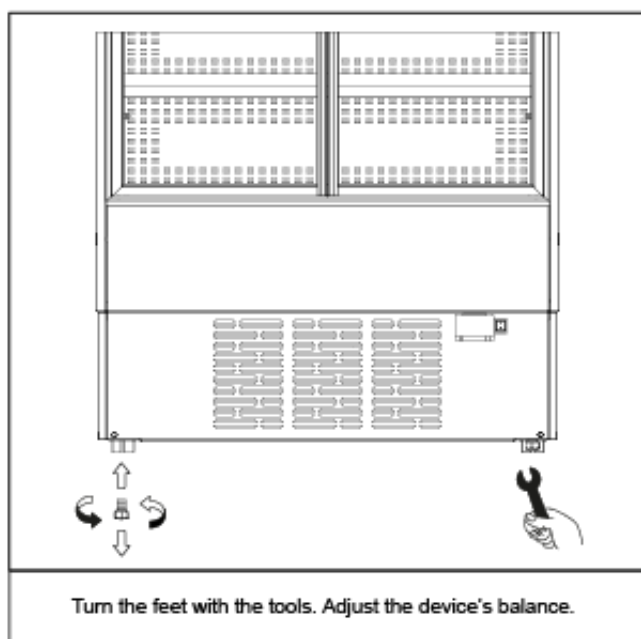

Cabinets on legs:

Cabinets on legs require an even, solid floor. Cabinets on legs are levelled by turning the internal part of the feet.

6) Condensation Water Re-evaporation

The cabinets are equipped with a chamber for re-evaporation of the condensation water on bottom of the cabinets. This equipment is intended for the amount of condensation water that accumulates on average with a maximum of 18 hours night blinds opened per day according to **ISO 23953-2**

The actual amount of condensation water may vary depending on usage and ambient conditions. If the duration number of night blind opened per day exceeds 18 hours, or the condensation water pan overflows due to other usage factors, the user must use the product strictly under the specified conditions to prevent overflow. If the amount of condensation increases despite not changing the usage or the ambient conditions, the cabinet may have a defective of body or/and there may be an obstruction of air flow system.

7) Electrical Connection

The 230 V/50 Hz mains connection is established by plugging the provided cable with appliance connector into a socket with earthed protective contact.

30 mA residual current circuit breaker is essential.

There may be special regulations from your local energy supply company regarding earthing measures that must be observed.



During working with the electrical equipment, the cabinet must always be disconnected from the mains by pulling out the power plug. It is NOT sufficient to switch off the cabinet with the ON/OFF button as parts of the cabinet are still live

8) Instructions for Daily Use

In order to achieve the necessary air circulation in the interior, only store goods within the corresponding markings (loading marks) and on the shelves (never in front of the air outlets).



Device shelves must be loaded with a maximum of 185 kg/m² of products.
This limit must not be exceeded.

No electrical cabinets may be operated inside the cabinet.

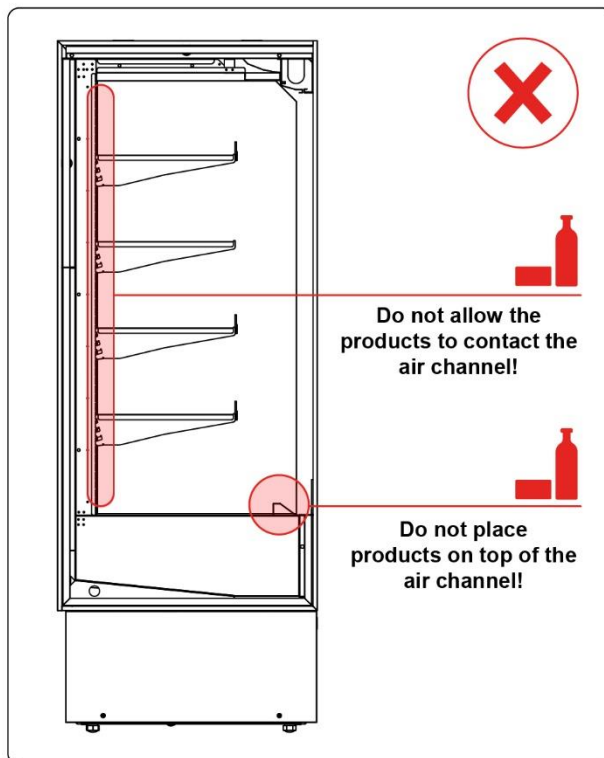

9) Cleaning and Maintenance

The cabinet must be cleaned regularly. The intervals depend on the usage and level of soiling (at least annually).



Before carrying out any cleaning or maintenance operations, unplug the unit



Don't touch or wet the machine compartment parts. This could result in failure or breakdown.



To prevent possible damage, don't clean the plastic parts with water above 40° C or in a dishwasher.

Interior & Exterior of Cabinet and Shelves



Clean the interior and exterior at least once a week for sanitary use.



Clean off the interior and exterior of cabinet with a soft cloth soaked in cold or warm water containing the proper amount of neutral cleaner and wrung dry. Don't use a water jet to clean the machine compartment.



Chemical agents other than neutral cleaner might cause damage to the interior and exterior surfaces.



Any remaining detergent will damage metal or plastic surfaces. Use a soft cloth dampened with warm water to wipe it off.



Don't use the following items, they could damage painted or plastic surfaces:

- Polishing powder, alcohol, thinner, benzene, acidic or alkaline detergent, hot water, petroleum, soap powder, metal scourer or brush, etc. Especially detergent to clean grease on ventilator or microwave

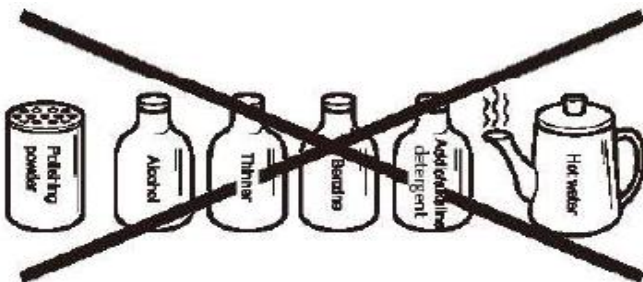

Note: Some solutions other than the above may also damage painted or plastic surfaces. Immediately stop using such solutions if they cause any problems!



The door gasket and its contact surface get soiled easily. Clean every surface of these parts thoroughly. Remnants of food will accelerate aging.



Use a cloth to wipe off any water staying inside the cabinet.

Condenser



Use vacuum cleaner or a soft brush to remove dust and stains from the condenser.



Warning: If users clean the condenser with hard brush, such as dishwasher brush, the coating of condenser may peel off.

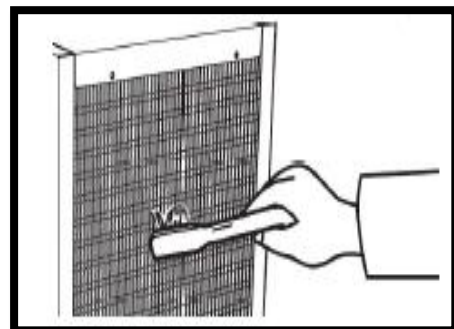

*Air Filter



To prevent deformation do not wash the air filter hot water above 40°



Plastic mesh air filters remove dirt or dust from the air and keep the condenser from getting clogged. If the filters get clogged, the refrigerator/freezer's performance will be reduced.



Check the filters at least twice a month. When clogged use warm water and a neutral cleaner to wash the filters. Don't operate the unit with the air filters removed, or the condenser will get clogged, resulting in failure.

- 1) a-Open the front panel and remove the air filter.
- 2) b-To prevent injury, don't touch the condenser fins directly.
- 3) Wash the air filter carefully with cold or warm water containing the proper amount of neutral cleaner. Rinse and dry the air filter thoroughly.
- 4) To refit the air filter, put the two tabs into the heat exchanger or fins in condenser and tightly attach the air filter over the condenser.

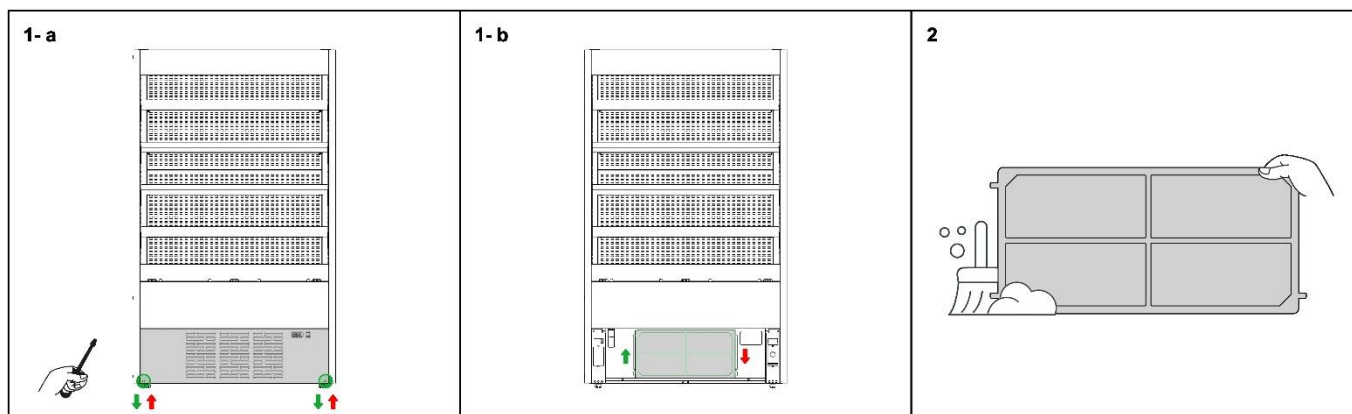



10) Control Elements

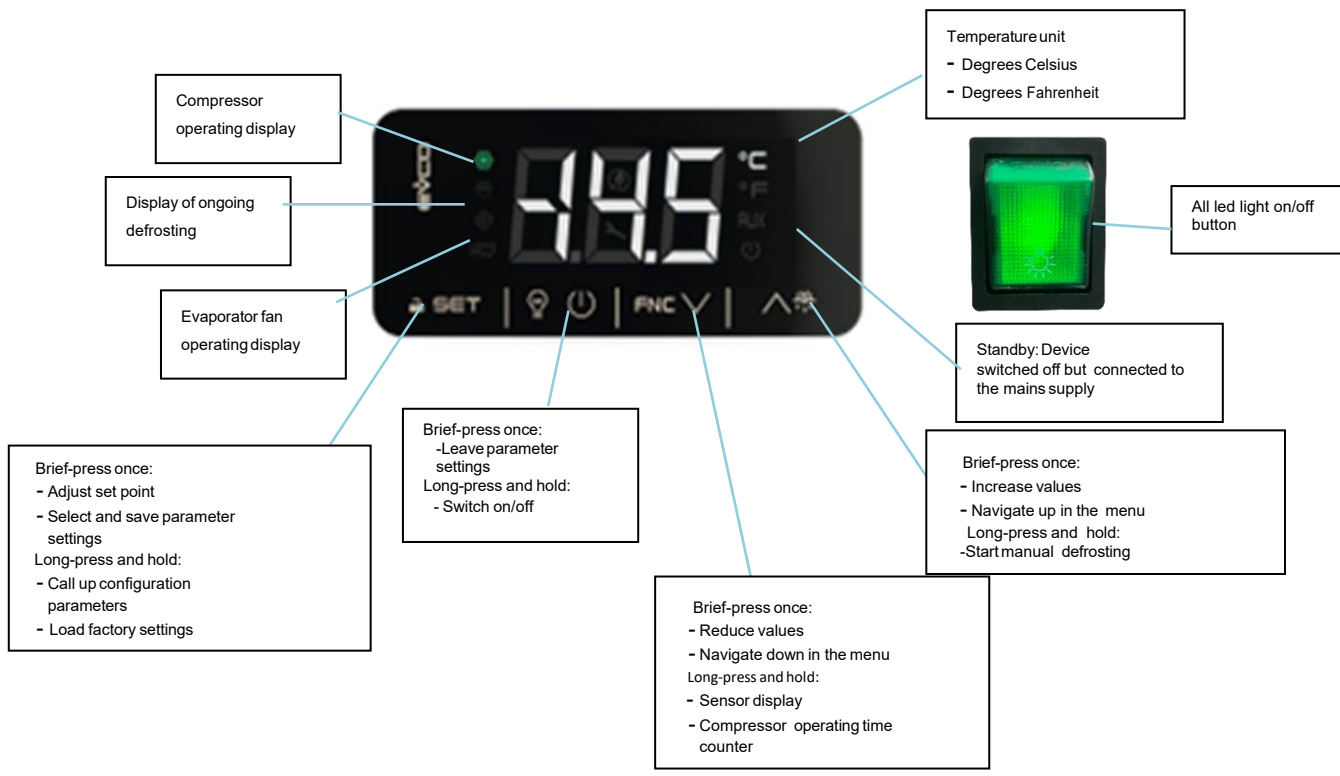

INDICATORS







TOUCH KEYS (CAPACITIVE)

Touch keys

Key	Function description
	By briefly pressing the key, you can adjust the set point or open a parameter within the parameter settings, save any value changes and leave the settings. By pressing the key for a longer time, you can call up the configuration parameters or the reset to factory settings. The longer key press will also remove the automatic key lock.
	By briefly pressing the key, you can discard a change in the parameter settings and exit the setting. By pressing the key for a longer time, you can switch the device on and off, provided the switch-off is not prevented by the parameter "POF"=0. The longer key press will also remove the automatic key lock.

Key	Function description
	By briefly pressing the key, you can increase the displayed value (set point, parameter or password input). Pressing the key for a longer time starts the manual defrosting. The longer key press will also remove the automatic key lock.
	By briefly pressing the key, you can decrease the displayed value (set point, parameter or password input). By pressing the key for a longer time, the sensor temperatures "Pb1", The longer key press will also remove the automatic key lock.

Display symbols

Symbol	Meaning
	This symbol shows that the device is connected to the mains supply but is switched off (standby mode).
	If this symbol lights up, the compressor is switched on. If this indicator flashes, either the temperature set point is being changed or the compressor is starting but is delayed by the controller safety settings (parameter "C0", "C1", "C2").
	This symbol lights up constantly throughout the defrosting. If it flashes, the dripping time is running or the start of the defrosting phase has begun but is delayed by a continuous minimum compressor running time.
	If this symbol lights up, the evaporator fan is running. If it flashes, the fan is deactivated or the start is delayed due to the parameter settings.

Device settings



All settings are configured via the capacitive touch keys of the control panel on the front of the device. There are no function elements for the menu selection, parameter settings or sensor calibration on the back of the device.

Commissioning

The cabinet must be connected to the mains using the connection cable provided (safety plug). This is followed by testing all the display segments.

If the device was switched off before being disconnected from the mains, the device will go into standby mode after the display test. If it was switched on before being disconnected from the mains, it starts in normal operation with the most recently set temperature set point.

Switching on (from standby state)

You switch on the cabinet by pressing the ON/OFF button  for approximately 4 seconds.  flashes while it is being switched on. No display test follows.





Start defrost

In the default settings, the device starts without a start defrost. If the parameter “d4” has been changed to “1”, the start defrost begins and lasts for max. the time period “d3” The compressor starts once the time period “C0” has elapsed at the earliest.







Key lock, sleep mode

The keys lock automatically if no key has been pressed for 30 seconds in order to prevent unintentional entries due to fleeting contact or while wiping the control panel. The abbreviation “Loc” is displayed in this case. “Loc” is also displayed when a key is touched while locked. The keypad can be unlocked by pressing any key for 4 seconds; “UnL” is displayed.

Display of set temperature (set point)

If required, the keypad can be unlocked by pressing any key for 4 seconds; "UnL" is displayed. Briefly press the key  SET; the compressor indicator  flashes and the temperature set point is displayed. By briefly pressing  SET or  again, or after 15 seconds without pressing any keys, the device returns to normal operation.

Temperature setting (changing the set point)

If required, the keypad can be unlocked by pressing any key for 4 seconds; "UnL" is displayed. Briefly press the key  SET; the compressor indicator  flashes and the temperature set point is displayed; it can be changed via  or . Press  SET to save the value and leave the parameter. You can leave and discard the change (escape) by pressing .





Switching off the device in standby mode:

You switch on the cabinet by pressing the ON/OFF button  for approximately 4 seconds.  flashes while it is being switched off. In standby mode,  is constantly lit.





Alarm and fault messages, display of the defrosting process

Indicator	Description
AL	Lower temperature alarm, parameter "A1", delay "A7"
AH	Upper temperature alarm, parameter "A4", delay "A7"
dEF	Device is undergoing the defrost process (if "D6"="2") or a reset to default factory settings
Pr1	Defective cabin sensor
Pr2	Defective Evaporator sensor







Room sensor temperature display

Press the key  for approx. 2 seconds until “rCH” appears, then press  until “Pb1” is displayed. The room temperature is displayed after pressing the key . The display disappears after briefly pressing  or , or automatically after 60 seconds without touching any keys.

Compressor run time display (operating time counter)

Press the key  for approx. 2 seconds until “rCH” appears, then press  until “CH” is displayed. The counter reading is displayed after pressing the key . The display disappears after briefly pressing  or , or automatically after 60 seconds without touching any keys.



Deleting the compressor run time (operating time counter)



Press the key  for approx. 2 seconds until “rCH” appears. If required, press  until “rCH” is displayed. Briefly press the key ; “0” is displayed. Within 15 seconds, press the key  or  to input the password “149” for resetting the counter and briefly press . The indicator “- -” flashes on the display for 4 seconds. The counter has been reset.







Setting the alarm limits

The controller does not manage separate user parameters except for the temperature set point “SP”. The alarm settings are configured in the configuration parameters; see below.

Reading and changing the service parameters

No other procedure can be running. Press and hold the key  SET for 4 seconds. "PA" is indicated on the display. Briefly press the key  SET; "0" is displayed.

Within 15 seconds, use the key  or  to input the password (default value "-19") and briefly press  SET. The first parameter "SP"(set point) is displayed.

Use the keys  and  to switch between the parameters and  SET to open a parameter. The set value appears, and it can be changed using  and . Press  SET to save the value and leave the parameter. You can leave and discard the change (escape) by pressing . You then leave the settings menu and return to the normal temperature display.

You can also leave the configuration parameter (while saving the changes) by pressing  SET for 4 seconds, or it happens automatically after 60 seconds if no further keys are pressed.

*The password can be changed via the "PAS" parameter.

PARAMETER LIST		ADVANCE MD K 100 BG KG/HG KG/ SW KG	ADVANCE MD K 120 BG KG/HG KG/ SW KG	ADVANCE MD K 150 BG KG/HG KG/ SW KG	ADVANCE MD K 180 BG KG/HG KG/ SW KG
P. CODE	DESCRIPTION	VALUE	VALUE	VALUE	VALUE
SP	Set point	3	3,5	3	3
CA1	cabinet probe offset	0	0	0	0
CA2	evaporator probe offset	0	0	0	0
P0	probe type	1	1	1	1
P1	enable °C decimal point	1	1	1	1
P2	temperature unit of measurement	0	0	0	0
P4	configurable input function	1	1	1	1
P5	value displayed	0	0	0	0
P8	display refresh time	0	0	0	0
P9	Second defrost parameter	0	0	0	0
r0	setpoint differential	2	2	2	2
r1	minimum setpoint	2,5	2,5	2,5	2,5
r2	maximum setpoint	6	6	6	6
r4	setpoint offset in energy saving	0	0	0	0
r5	cooling or heating operation	0	0	0	0
r12	position of the r0 differential	0	1	0	1
r13	Second defrost activation	2	2	2	2
C0	compressor on delay after power-on	0	0	0	0
C2	compressor off minimum time	3	3	3	3
C3	compressor on minimum time	0	0	0	0
C4	compressor off time during cabinet probe alarm	0	0	0	0
C5	compressor on time during cabinet probe alarm	10	10	10	10
C6	threshold for high condensation warning	80	80	80	80
C7	threshold for high condensation alarm	90	90	90	90
C8	high condensation alarm delay	1	1	1	1
C10	compressor hours for service	0	0	0	0
d0	automatic defrost interval	4	4	4	4
d0b	automatic defrost interval for B	4	4	4	4
d1	defrost type	0	0	0	0
d1b	defrost type for B	0	0	0	0
d2	threshold for defrost end	8	8	8	7,5
d2b	threshold for defrost end for B	8	8	8	7,5
d3	defrost duration	60	60	60	60

		ADVANCE MD K 100 BG N/HG N/ SW N	ADVANCE MD K 120 BG N/HG N/ SW N	ADVANCE MD K 150 BG N/HG N/ SW N	ADVANCE MD K 180 BG N/HG N/ SW N
P. CODE	DESCRIPTION	VALUE	VALUE	VALUE	VALUE
d3b	defrost duration for B	60	60	60	60
d4	enable defrost at power-on	0	0	0	0
d5	defrost delay after power-on	0	0	0	0
d6	value displayed during defrost	2	2	2	2
d7	dripping time	1	1	1	1
d7b	dripping time for B	1	1	1	1
d8	defrost interval counting mode	0	0	0	0
d9	evaporation threshold for automatic defrost interval counting	0	0	0	0
d11	enable defrost timeout alarm	0	0	0	0
d15	compressor on consecutive time for hot gas defrost	0	0	0	0
d16	pre-dripping time for hot gas defrost	0	0	0	0
d18	adaptive defrost interval	999	999	999	999
d19	threshold for adaptive defrost (relative to optimal evaporation temperature)	3	3	3	3
d20	compressor on consecutive time for defrost	999	999	999	999
d22	evaporation threshold for adaptive defrost interval counting (relative to optimal evaporation temperature)	-2	-2	-2	-2
A1	threshold for low temperature alarm	10	10	10	10
A4	threshold for high temperature alarm	10	10	10	10
A6	high temperature alarm delay after power-on	120	120	120	120
A7	high/low temperature alarms delay	120	120	120	120
A8	high temperature alarm delay after defrost	120	120	120	120
A9	high temperature alarm delay after door closing	120	120	120	120
A11	high/low temperature alarms reset differential	1	1	1	1
F0	evaporator fan mode during normal operation	1	1	1	1
F0b	evaporator fan mode during normal operation for B	1	1	1	1
F1	threshold for evaporator fan operation	0	0	0	0
F2	evaporator fan mode during defrost and dripping	1	1	1	1
F2b	evaporator fan mode during defrost and dripping for B	1	1	1	1
F3	evaporator fan off maximum time	1	1	1	1
F3b	evaporator fan off maximum time for B	1	1	1	1
F4	evaporator fan off time during energy saving	0	0	0	0

		ADVANCE MD K 100 BG N/HG N/ SW N	ADVANCE MD K 120 BG N/HG N/ SW N	ADVANCE MD K 150 BG N/HG N/ SW N	ADVANCE MD K 180 BG N/HG N/ SW N
P. CODE	DESCRIPTION	VALUE	VALUE	VALUE	VALUE
F5	evaporator fan on time during energy saving	0	0	0	0
F7	threshold for evaporator fan on after dripping (relative to setpoint)	5	5	5	5
F8	threshold for evaporator fan operation differential	2	2	2	2
F9	evaporator fan off delay after compressor off	10	10	10	10
F10	condenser fan mode	1	1	1	1
i0	door switch input function	0	0	0	0
i1	door switch input activation	0	0	0	0
i2	open door alarm delay	-1	-1	-1	-1
i3	regulation inhibition maximum time with door open	0	0	0	0
i10	door closed consecutive time for energy saving	0	0	0	0
i13	number of door openings for defrost	0	0	0	0
i14	door open consecutive time for defrost	0	0	0	0
HE2	energy saving maximum duration	720	720	720	720
HE3	energy saving minimum duration	720	720	720	720
POF	Key activation	1	1	1	1
PAS	Access to password	-19	-19	-19	-19





11) Led Light And Glass Door Assembl

Change to Glass Door ,



**Here are the steps to follow for glass door replacement.
 Risk of injury !**





<p>1. Remove the plastic hinge cover pieces at the bottom and top of the door.</p>	<p>2. Hold the door as shown in the picture. Using a tool , gently push upward from the hinge side. The hinge will come out of its lower slot.</p>	<p>3. As shown in the picture, remove the upper hinge pin of the door from its socket. The door removal procedure is complete. Store the door carefully in a horizontal position on a soft surface.</p>
<p>4. To install the door into its housing, the hinge at the bottom of the door must be adjusted with a wrench as shown in the picture.</p>	<p>5. First, the upper hinge pin must be installed into its socket. The picture shows the upper and lower hinge sockets.</p>	<p>6. The adjusted lower hinge must be slowly positioned into its slot using a tool. This procedure must be carried out by trained technical personnel.</p>

		
<p>7.To eliminate any gaps in the gasket between the doors, the hinge part shown in the picture must be precisely adjusted and secured with a screw.</p>	<p>8. Please make sure that there is no gap in the gasket between the doors.</p>	<p>9.Install the hinge visible parts.</p>
		
<p>10.Please check the door gaskets. Ensure that the door gasket is properly contacting the frame.</p>		

Change to Led Light ,



Please unplug the device before replacing the led lighting

		
<p>1. Turn off the energy.</p>	<p>2. Remove the shelf sheet.</p>	<p>3. Open the clips inside the cable camouflage sheet metal.</p>
		
<p>4. Remove the led lighting screws with tools. Install the new lighting in its place.</p>	<p>5. Insert the cable ends into the clips properly. Place the clips back in their position.</p>	<p>6. Put the sheet metal of the shelf back in place. Turn on the energy.</p>

12) Measures for Taking the Cabinet Out of Operation for Long Periods

- Disconnect the power plug from the socket or switch off the circuit fuse.
- Remove all foods from the cabinet.
- Clean the cabinet (see cleaning section).
- Do not fully close the glass door; this will prevent unpleasant odors.



Warning

Please note that as soon as you disconnect the cabinet from the mains, the air curtain will disappear. Condensation may appear on the surface of the cabinet. Condensation water may drip from the cabinet onto the floor. This could damage the floor and make it slippery.

13) Disposal

Electrical and electronic equipment (EEE) contains materials, components and substances that could pose a threat to humans and the environment if proper disposal (WEEE) is not observed.

Products labelled with a crossed-out bin symbol belong to this group of electrical and electronic components. The crossed-out bin symbol indicates that this type of waste must not be disposed of with regular household waste, but must instead be collected and sorted separately.

If the cabinet requires disposal, this must be carried out in a proper and environmentally friendly manner. The applicable laws and directives related to disposal must be observed.



Please ask your specialist dealer or your local authority about proper disposal.



14) Technical Data:

Placement of the label:

PRODUCT DESCRIPTION LABEL		
1 Product Number		
2 Product Description		
3 Model		
4 Refrigerant (GWP)		
5 CO2 Equivalent		
6 IP Protection		
7 Climate Class		
8 Production Date		
9 Total power / Current / Lamp power		
10 Voltage - Frequency		
11 Heating Element		
12 System Pressure		
13 Blowing Agent		
14 Serial Number		

Trademark			HOSHIZAKI							
Model name			ADVANCE MD K 100 BG KG/ 100 HG KG	ADVANCE MD K 120 BG KG/ 120 HG KG	ADVANCE MD K 150 BG KG/ 150 HG KG	ADVANCE MD K 180 BG KG/ 180 HG KG	ADVANCE MD K 100 SW KG	ADVANCE MD K 120 SW KG	ADVANCE MD K 150 SW KG	ADVANCE MD K 180 SW KG
Intended use			DISPLAY CABINET							
Chilled operating temperature			X	X	X	X	X	X	X	X
Frozen operating temperature										
Multiuse cabinet										
Vertical cabinet			X	X	X	X	X	X	X	X
Counter cabinet										
Parameter	Symbol	Unit								
Energy Efficiency Class	EEC	-	B	B	B	B	B	B	C	C
Energy Efficiency Index	EEl	-	12,33	12,54	15,02	19,56	19,67	19,02	21,81	27,46
24 hours Energy Consumption	E24h	kWh	4,485	4,993	6,552	9,231	4,485	4,993	6,552	9,231
Annual Energy Consumption	AEC	kWh	1637	1822	2391	3369	1637	1822	2391	3369
Net volume	Vn	litre	435	530	670	815	435	530	670	815
Max. capacity of a shelve		kg	65	80	50	60	65	80	50	60
Climate Class	CC		3	3	3	3	3	3	3	3
Voltage/Frekans			230V/50Hz	230V/50Hz	230V/50Hz	230V/50Hz	230V/50Hz	230V/50Hz	230V/50Hz	230V/50Hz
Refrigerant			R290	R290	R290	R290	R290	R290	R290	R290
Charge		kg	0,145	0,149	2X0,149	2X0,145	0,145	0,149	2X0,149	2X0,145
GWP			3	3	3	3	3	3	3	3
CO2 Equivalent		t. CO2	0,000435	0,000447	0,000894	0,00084	0,000435	0,000447	0,000894	0,00084
Heavy-duty; This appliance is intended for use in ambient temperatures up to 25°C %60RH			X	X	X	X	X	X	X	X

15) Dimensions

ADVANCE MD K 100 BG KG

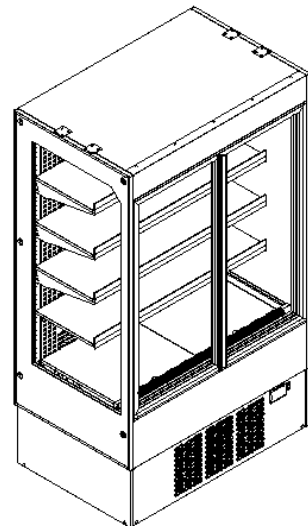
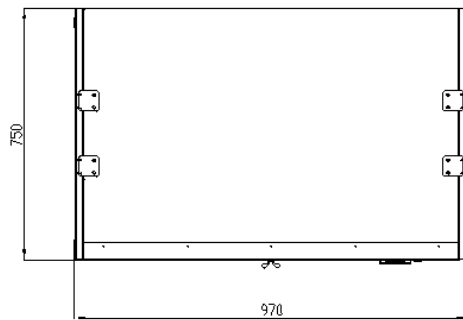
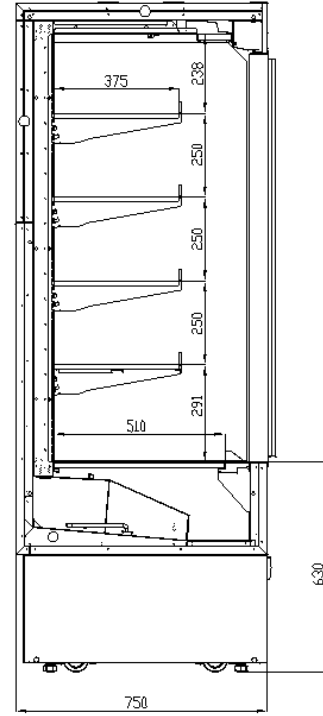
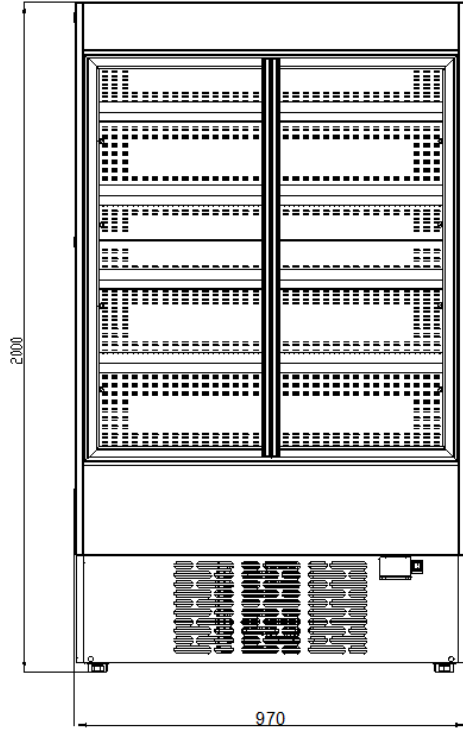

ADVANCE MD K 120 BG KG

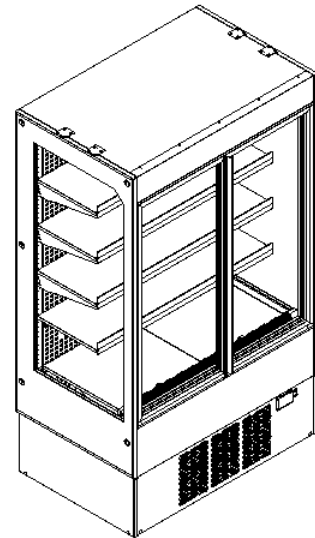
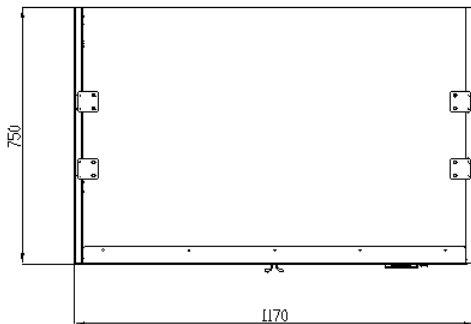
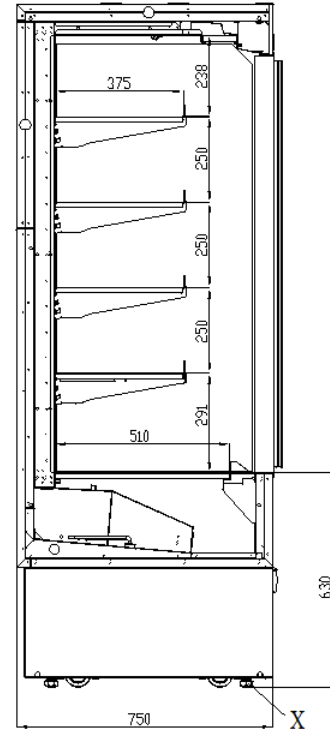
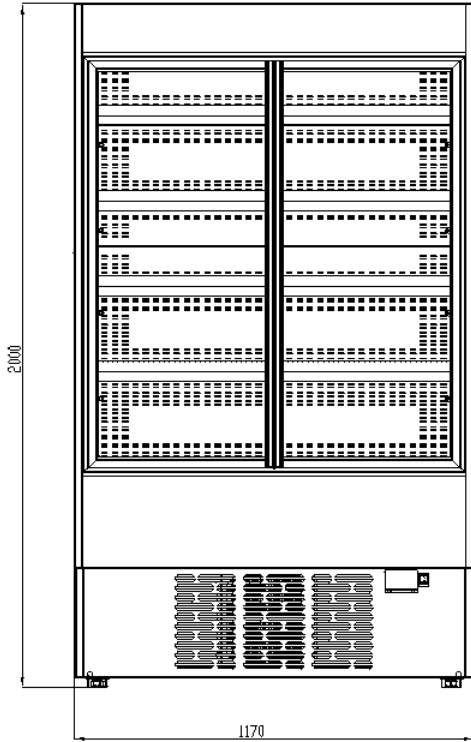

ADVANCE MD K 150 BG KG

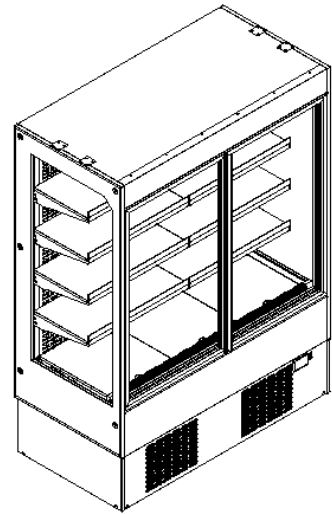
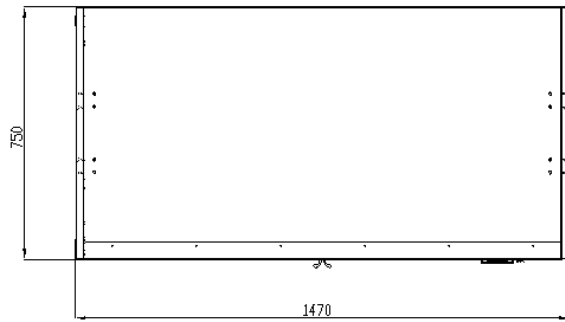
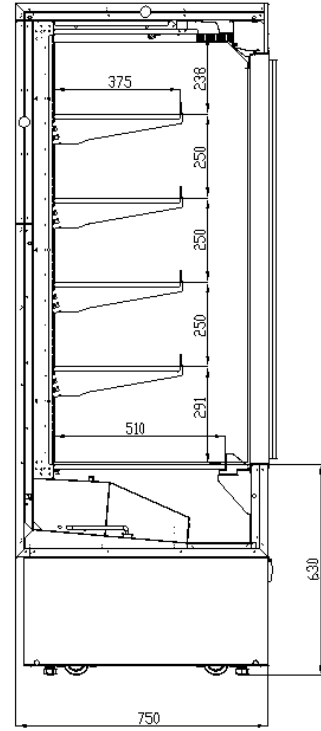
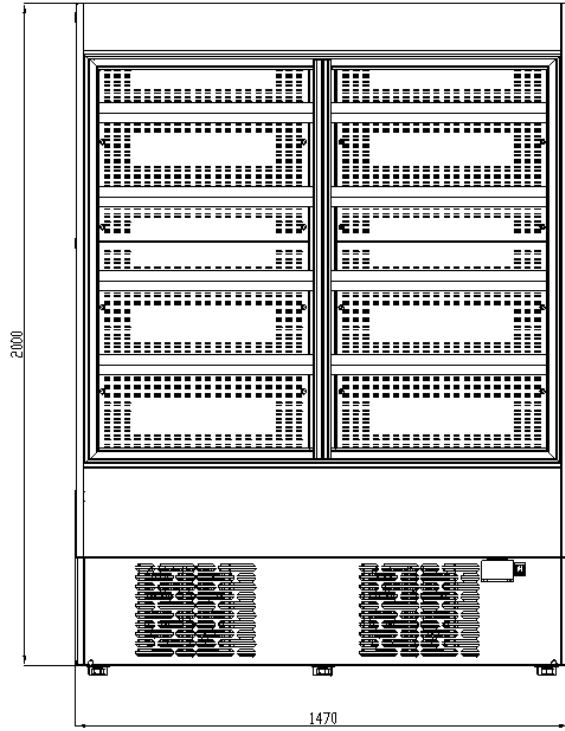

ADVANCE MD K 180 BG KG

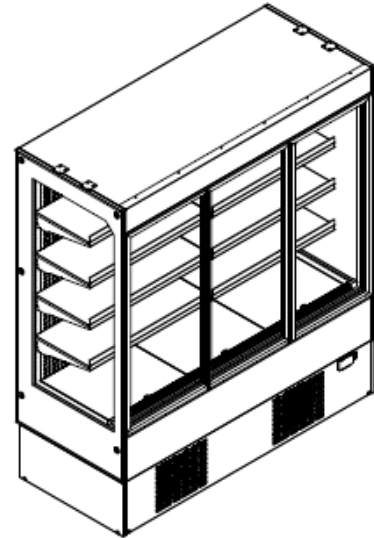
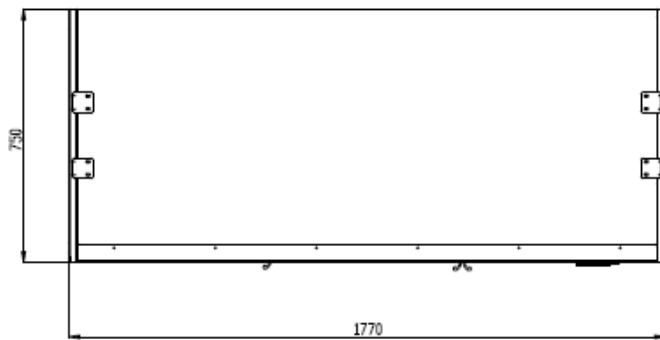
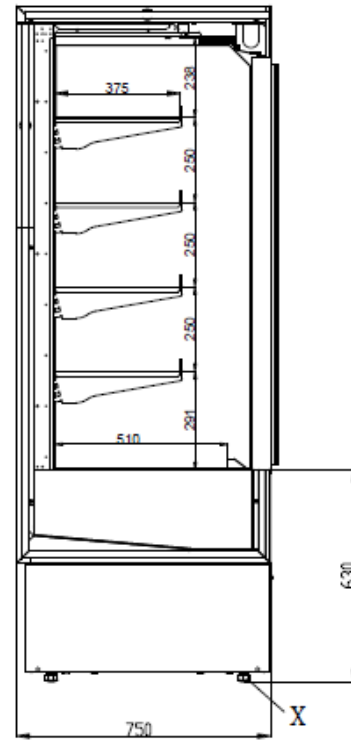
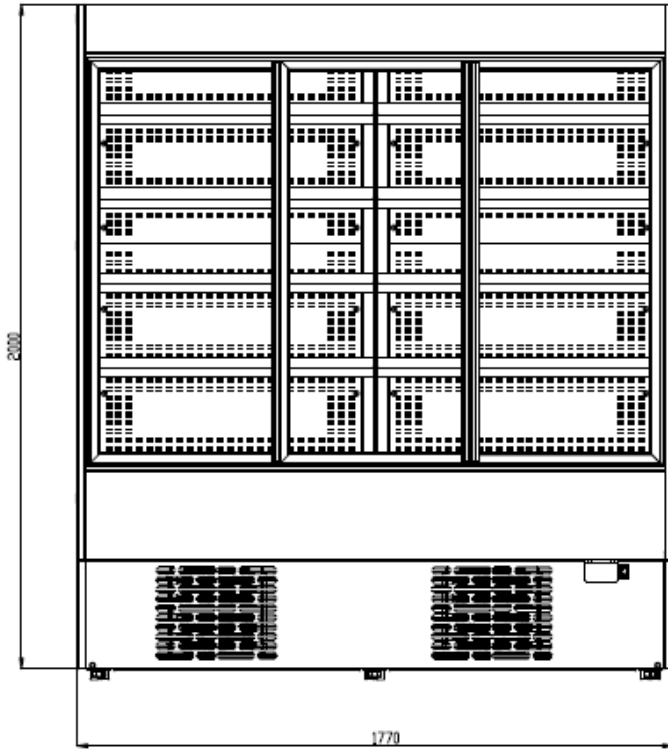

ADVANCE MD K 100 HG KG

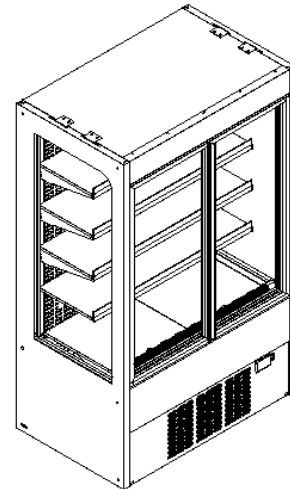
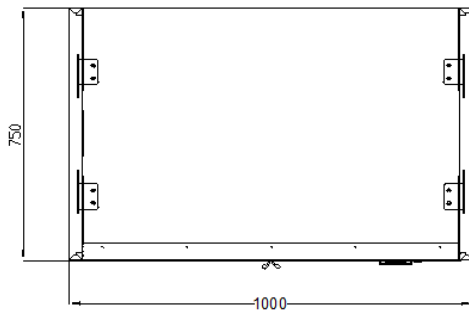
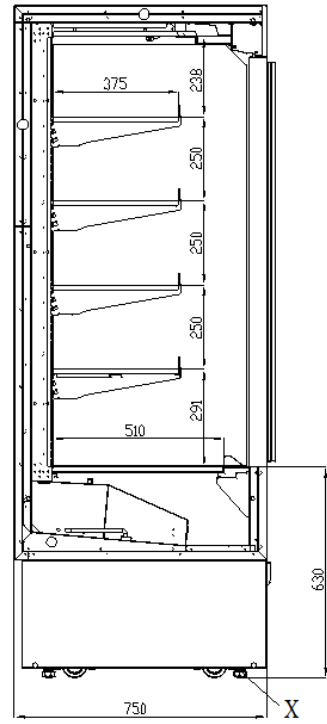
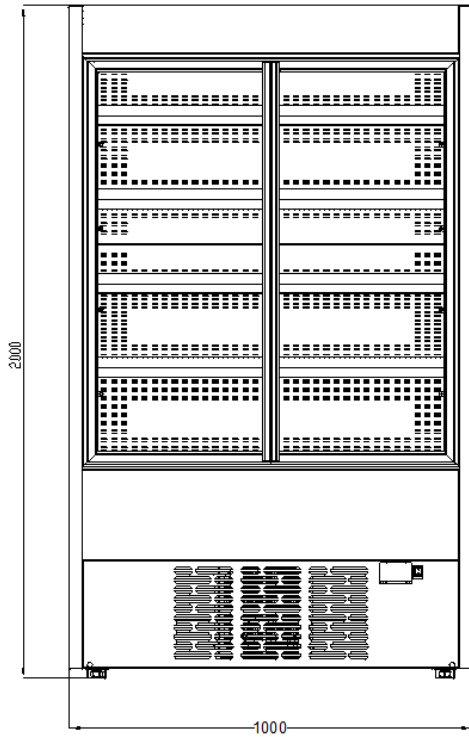

ADVANCE MD K 120 HG KG

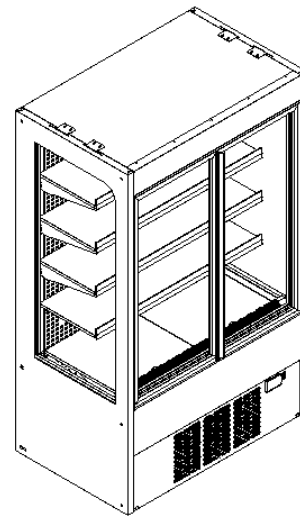
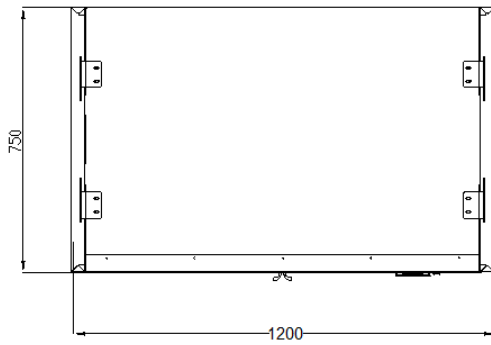
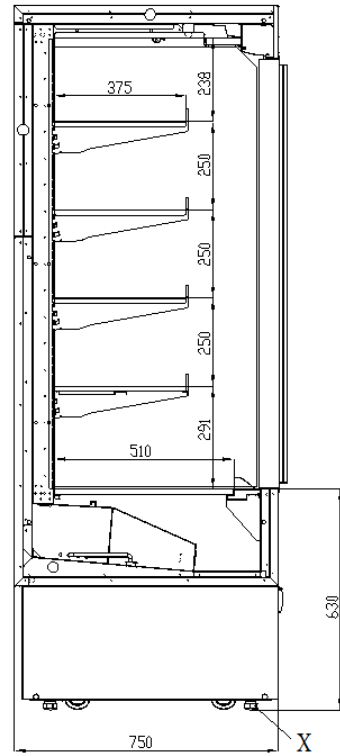
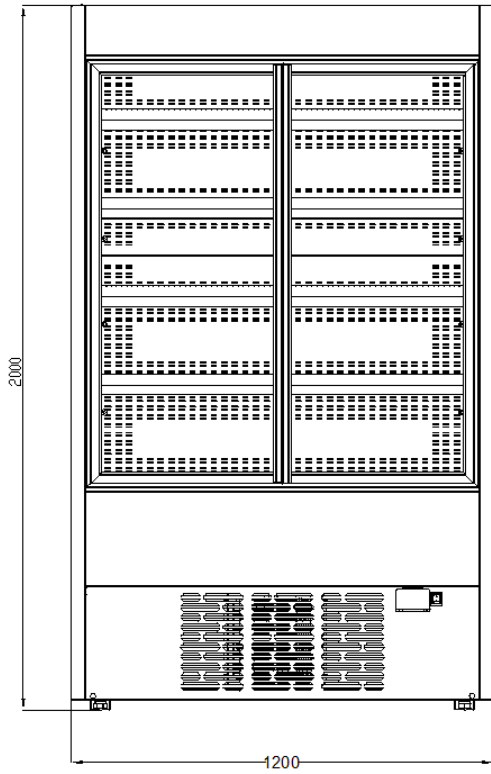

ADVANCE MD K 150 HG KG

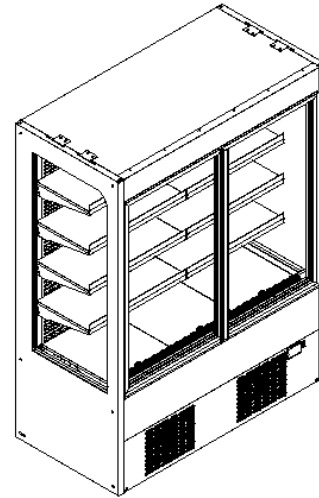
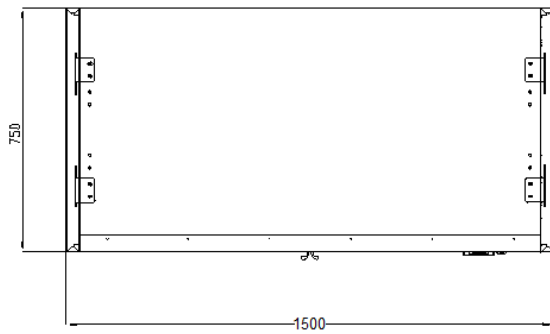
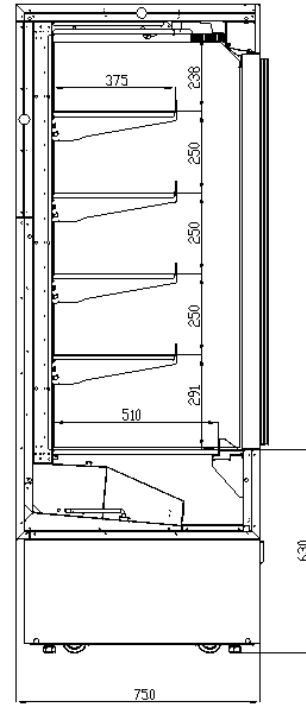
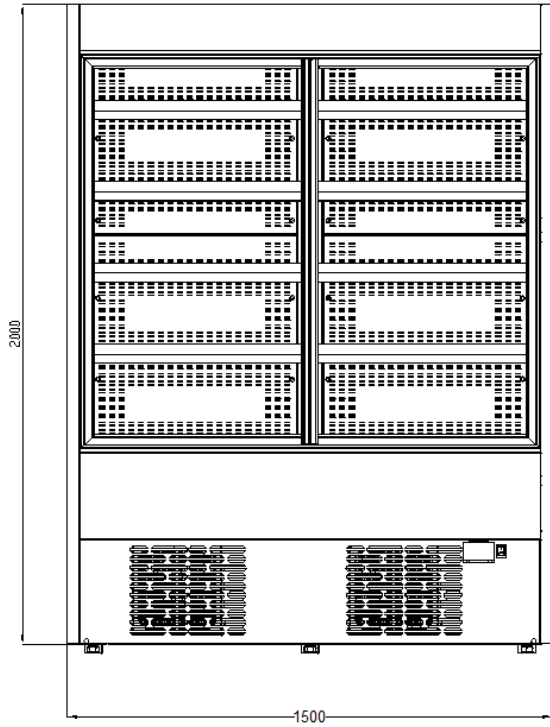

ADVANCE MD K 180 HG KG

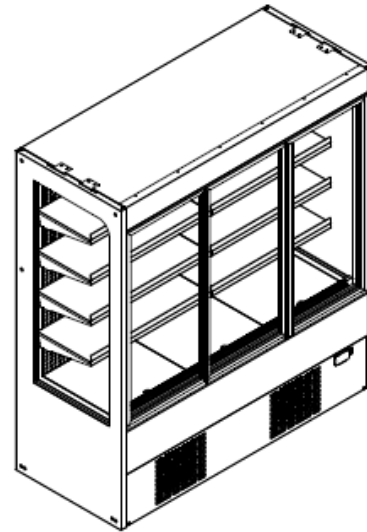
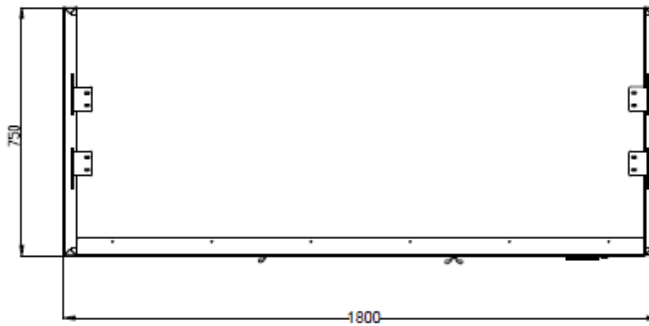
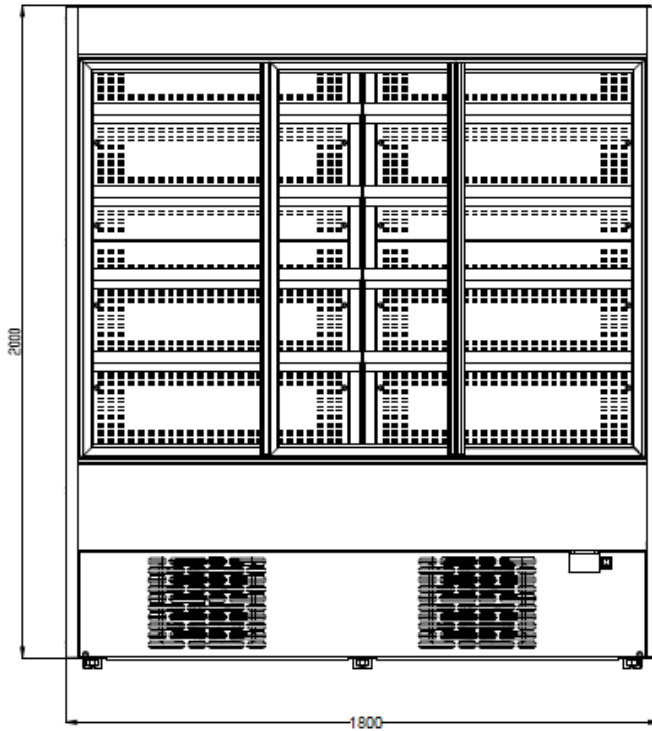

ADVANCE MD K 100 SW KG

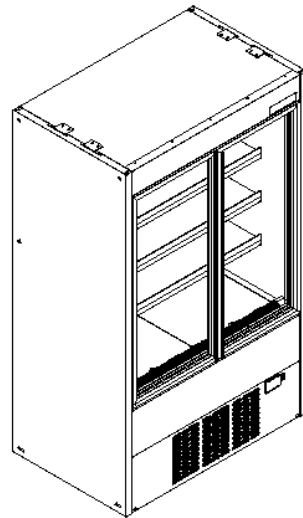
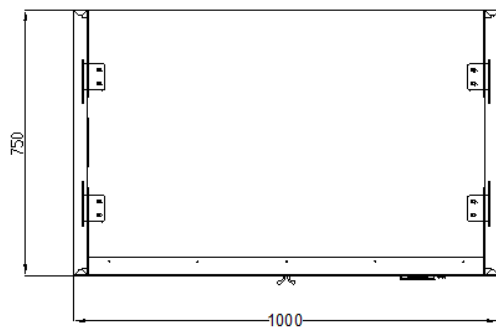
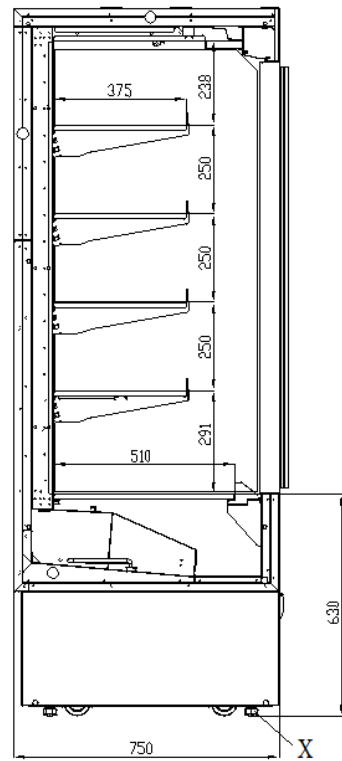
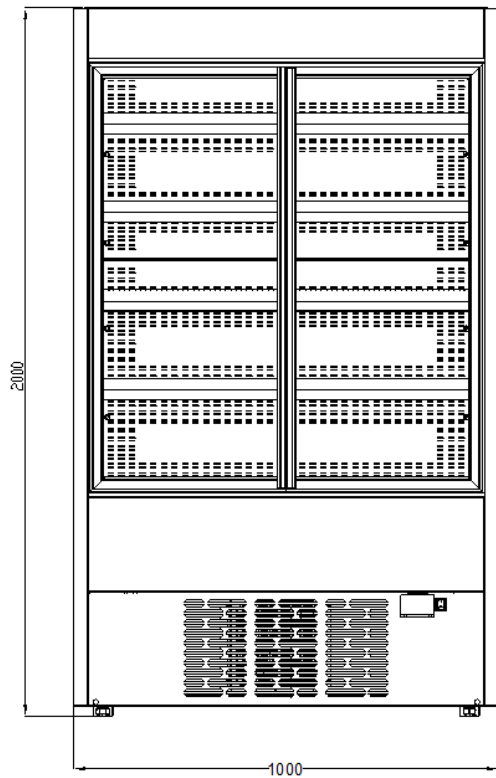

ADVANCE MD K 120 SW KG

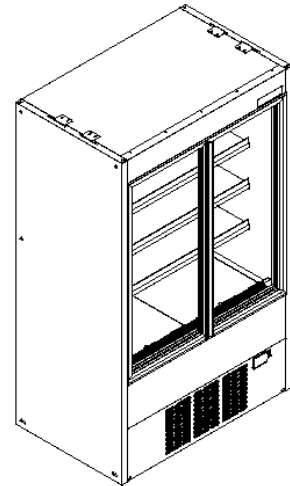
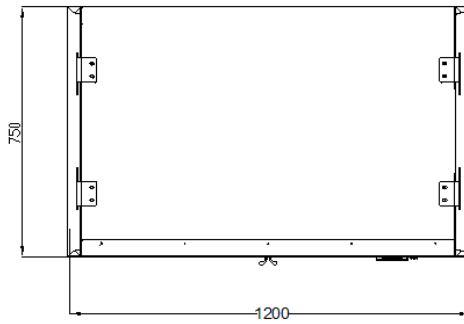
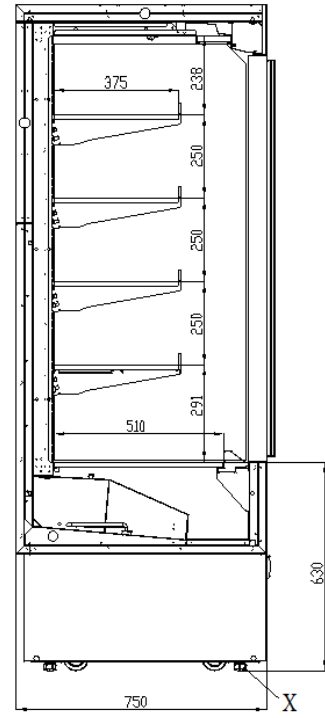
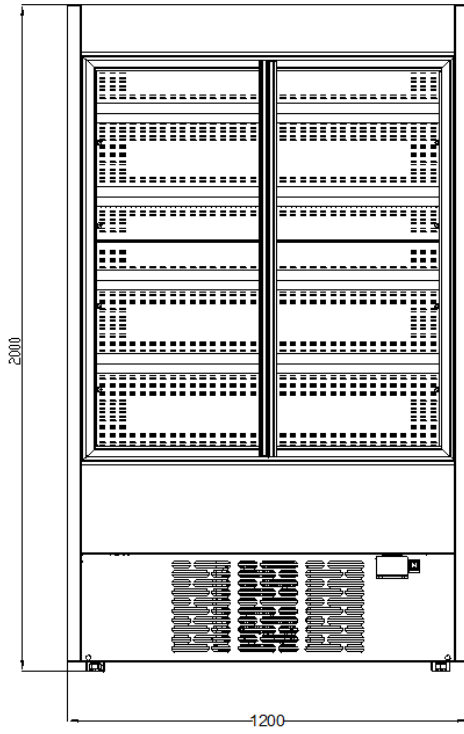

ADVANCE MD K 150 SW KG

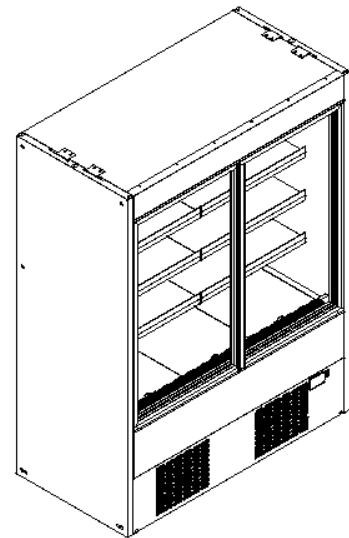
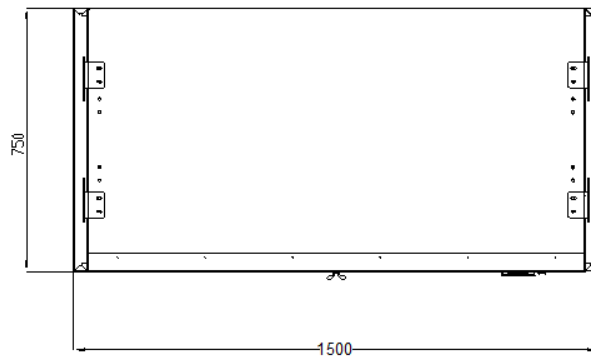
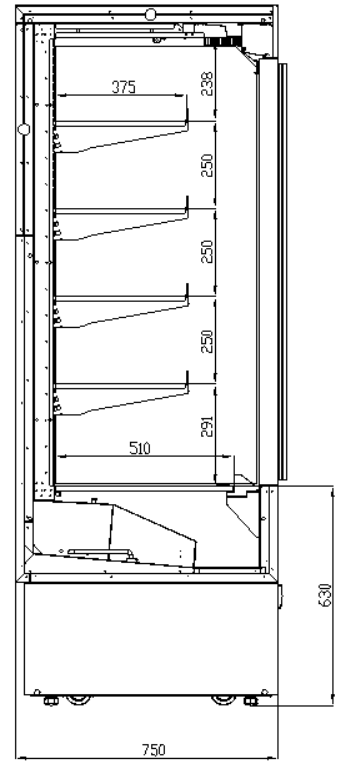
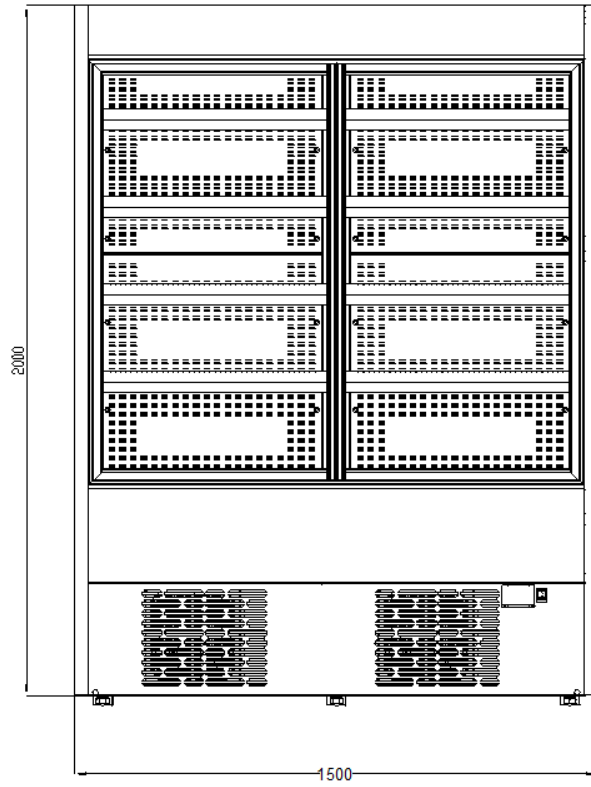

ADVANCE MD K 180 SW KG

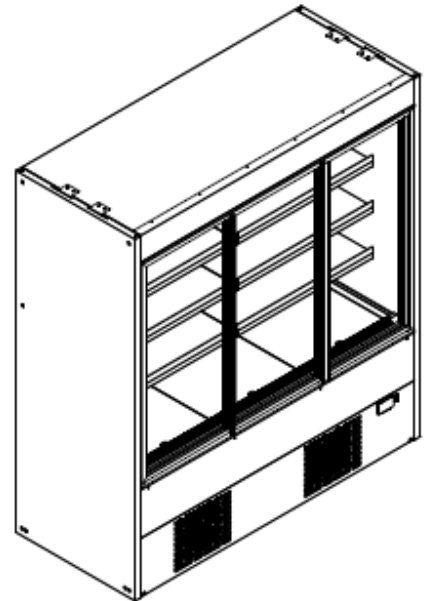
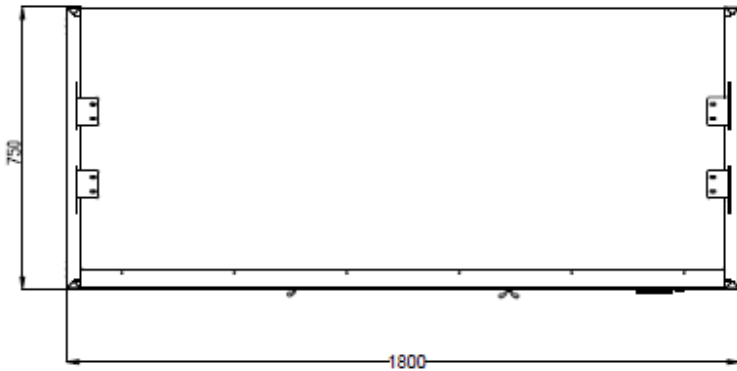
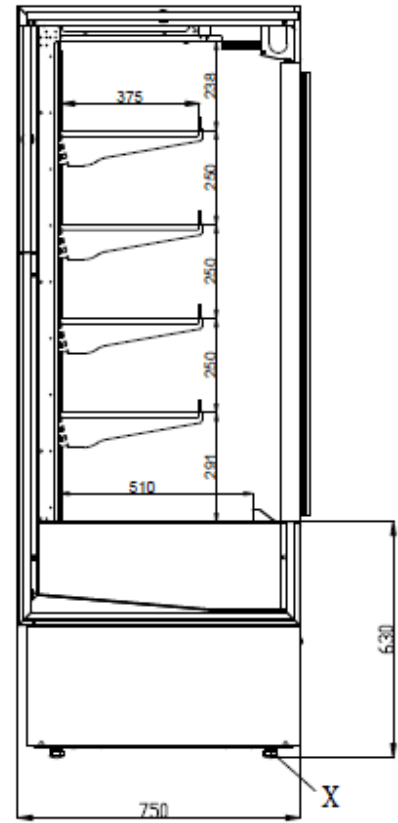
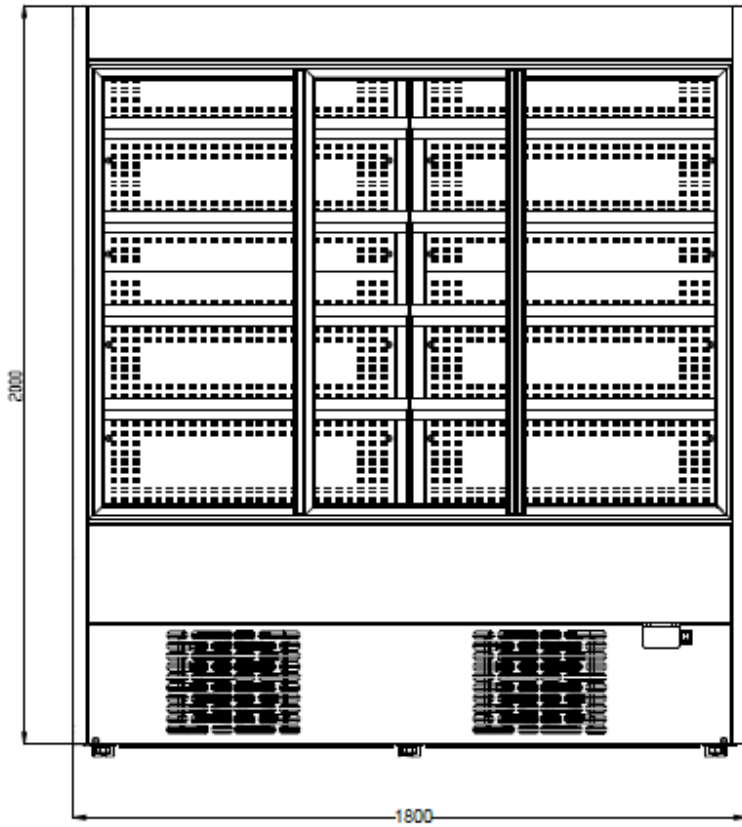

16) Wiring Diagram

ELECTRICAL WIRING DIAGRAM (FOR MULTIDECK WITH GLASS DOOR)

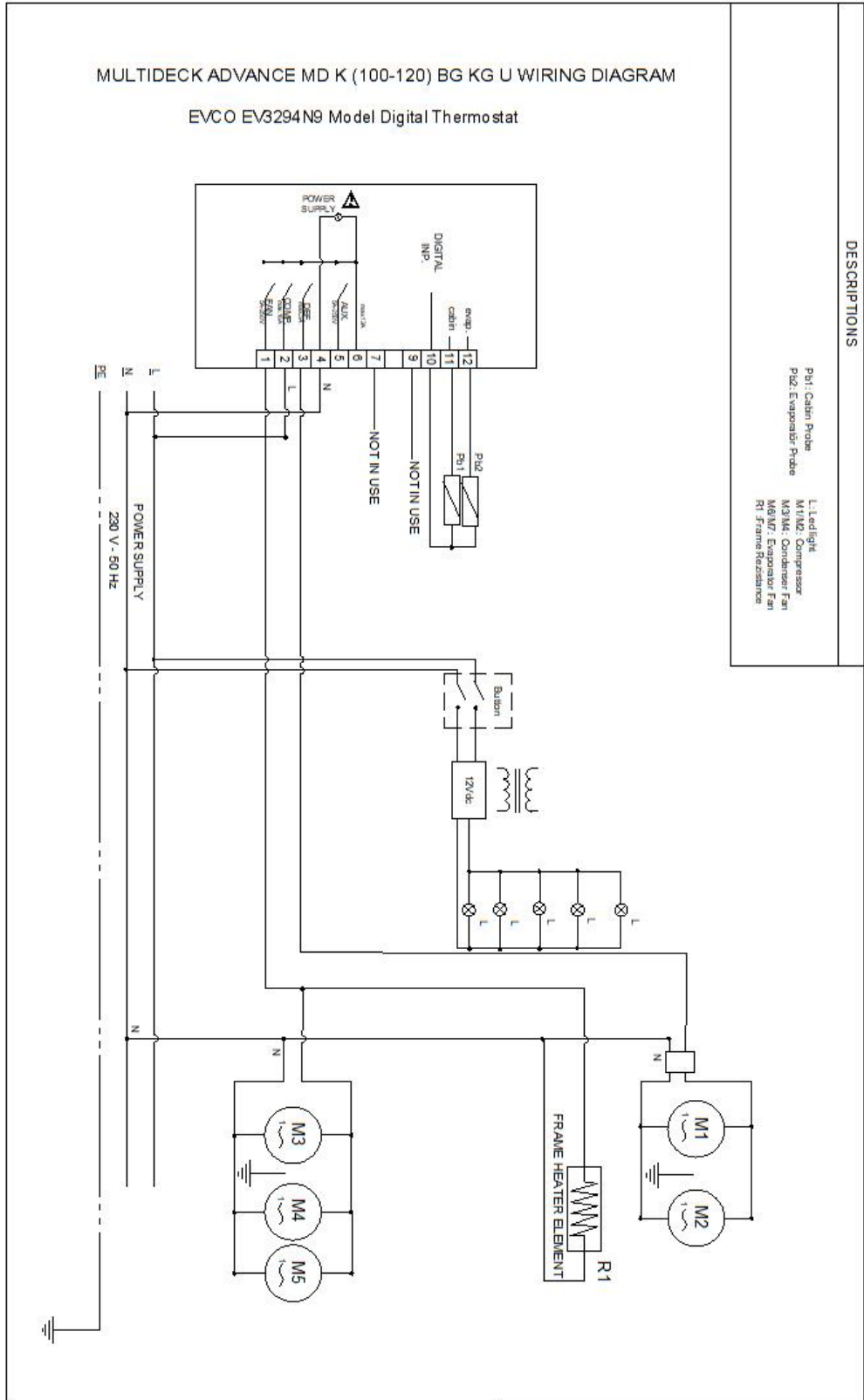

MULTIDECK ADVANCE MD K (150-180) BG KG U WIRING DIAGRAM

EVCO EV3B23N7 Model Digital Thermostat

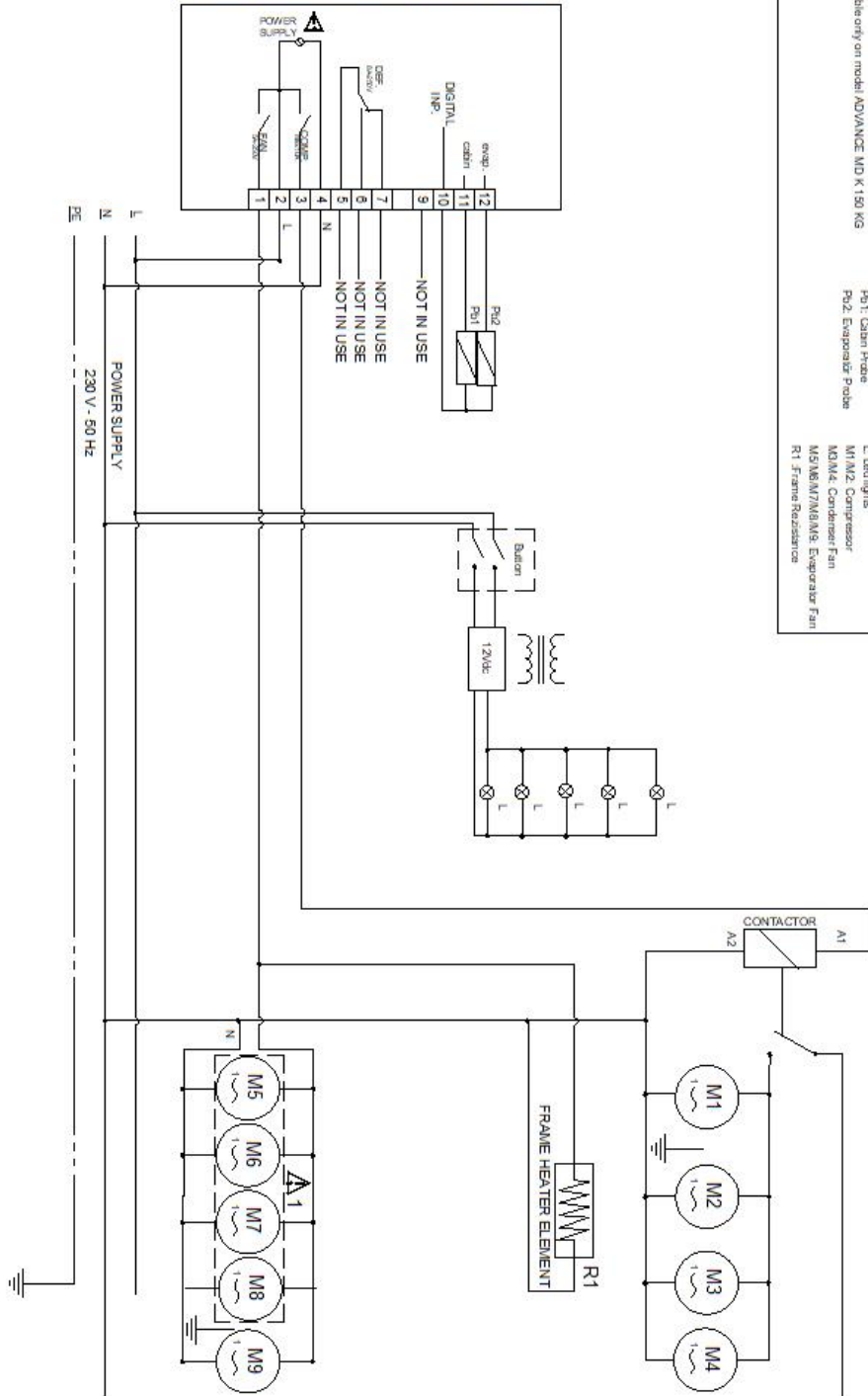

DESCRIPTIONS

▲ Available only on model ADVANCE MD K 150 KG

Pt1: Cabin Probe
 Pt2: Evaporator Probe

L: Ledlights
 M1/M2: Compressor
 M3/M4: Condenser Fan
 M5/M6/M7/M8/M9: Evaporator Fan
 R1: Frame Resistance

17) Cooling Diagram

ADVANCE MD K 100 KG / ADVANCE MD K 120 KG Cooling Diagram

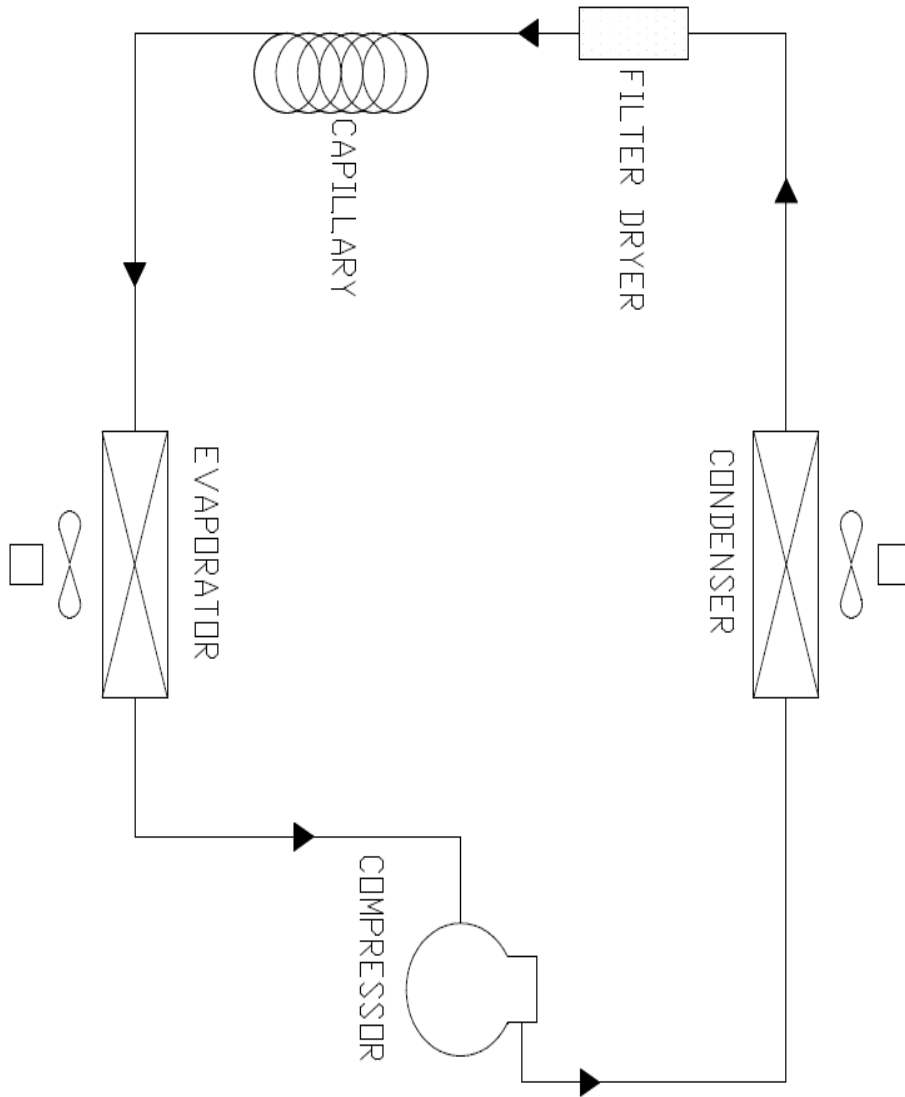

ADVANCE MD K 150 KG / ADVANCE MD K 180 KG Cooling Diagram

