



SELF-CONTAINED CUBER

SERVICE MANUAL

**IM-21CNE
IM-30CNE
IM-30CWNE
IM-45CNE
IM-45NE
IM-45WNE
IM-65NE
IM-65WNE
IM-100CNE
IM-100NE
IM-100WNE
IM-130NE
IM-130WNE
IM-240NE
IM-240WNE**

CONTENTS

PAGE

I. SPECIFICATIONS -----	1
1. DIMENSIONS/SPECIFICATIONS-----	1
[a] IM-21CNE -----	1
[b] IM-30CNE -----	2
[c] IM-30CWNE -----	3
[d] IM-45CNE -----	4
[e] IM-45NE -----	5
[f]IM-45WNE -----	6
[g] IM-65NE -----	7
[h] IM-65WNE -----	8
[i] IM-100CNE -----	9
[j] IM-100NE -----	10
[k] IM-100WNE-----	11
[l] IM-130NE -----	12
[m] IM-130WNE-----	13
[n] IM-240NE -----	14
[o] IM-240WNE-----	15
II. GENERAL INFORMATION -----	16
1. CONSTRUCTION -----	16
[a] IM-21CNE, IM-30CNE -----	16
[b] IM-30CWNE -----	17
[c] IM-45CNE -----	18
[d] IM-45NE, IM-65NE-----	19
[e] IM-45WNE, IM-65WNE -----	20
[f] IM-100CNE -----	21
[g] IM-100NE, IM-130NE -----	22
[h] IM-100WNE, IM-130WNE-----	23
[i] IM-240NE -----	24
[j] IM-240WNE-----	25
2. CONTROLLER BOARD -----	26
[a] CONTROLLER BOARD LAYOUT -----	27
[b] INPUT/OUTPUT LAYOUT -----	28
[c] BEFORE CHECKING CONTROLLER BOARD -----	29
III. OPERATING INSTRUCTIONS-----	30
1. START UP -----	31
2. PREPARING THE ICEMAKER FOR LONG STORAGE-----	31
[a] IM-21, 30, 45, 65 -----	31
[b] IM-100, 130, 240 -----	32
3. BIN CONTROL-----	33
[a] BIN CONTROL SWITCH ASSEMBLY -----	33
[b] REMOVAL-----	34
[c] REASSEMBLING -----	34

IV. MAINTENANCE INSTRUCTIONS -----	35
1. PERIODICAL CLEANING -----	35
2. WATER VALVE -----	37
3. WATER-COOLED CONDENSER -----	38
4. ICEMAKING WATER SYSTEM -----	39
V. TECHNICAL INFORMATION -----	42
1. WATER CIRCUIT AND REFRIGERANT CIRCUIT -----	42
[a] IM-21CNE, IM-30CNE, IM-45CNE, IM-45NE, IM-65NE -----	42
[b] IM-100CNE, IM-100NE, IM-130NE, IM-240NE -----	43
[c] IM-65WNE -----	44
[d] IM-30CWNE, IM-45WNE, IM-100WNE, IM-130WNE, IM-240WNE -----	45
2. WIRING DIAGRAM -----	46
[a] IM-21CNE, IM-30CNE, IM-30CWNE -----	46
[b] IM-45CNE, IM-45NE, IM-45WNE, IM-65NE, IM-65WNE -----	47
[c] IM-100CNE, IM-100NE, IM-100WNE, IM-130NE, IM-130WNE -----	48
[d] IM-240NE, IM-240WNE -----	49
3. PERFORMANCE DATA -----	50
[a] COPELAND COMPRESSOR -----	56
[b] SECOP (DANFOSS) COMPRESSOR -----	58
VI. SERVICE DIAGNOSIS -----	59
1. ERROR CODE INDICATION -----	59
2. NO ERROR CODE INDICATION -----	60
VII. ADJUSTMENT -----	62
1. EXPANSION VALVE -----	62
2. WATER REGULATING VALVE - WATER-COOLED MODEL ONLY -----	63
3. FULL DRAIN FLUSH -----	64
4. DIMPLE DIAMETER -----	64
VIII. REMOVAL AND REPLACEMENT -----	65
1. SERVICE FOR REFRIGERANT LINES -----	65
[a] SERVICE INFORMATION -----	65
[b] REFRIGERANT RECOVERY -----	66
[c] EVACUATION AND RECHARGE -----	67
2. COMPRESSOR -----	68
3. DRIER -----	69
4. EXPANSION VALVE -----	70
5. EVAPORATOR -----	71
6. HOT GAS VALVE -----	72
7. WATER REGULATING VALVE - WATER-COOLED MODEL ONLY -----	73
[a] VALVE BODY -----	73
[b] WHOLE VALVE -----	73
8. WATER PAN ASSEMBLY -----	75
9. PUMP MOTOR -----	77
10. WATER VALVE -----	77

11. ACTUATOR MOTOR -----	78
12. CAM -----	79
[a] CAM (A) - ACTUATOR MOTOR SIDE -----	79
[b] CAM (B) - REAR SIDE -----	79
13. CONTROLLER BOARD -----	81
14. THERMISTOR FOR CUBE CONTROL -----	86
15. FAN MOTOR - AIR-COOLED MODEL ONLY -----	87
16. WATER SUPPLY PIPE -----	87

I. SPECIFICATIONS

1. DIMENSIONS/SPECIFICATIONS

[a] IM-21CNE (Air-cooled)

ITEM	Hoshizaki Cube Ice Maker
MODEL	IM-21CNE
POWER SUPPLY	1 PHASE 220-240V 50Hz Capacity: Min. 0.66kVA (2.8A)
AMPERAGE	Running: 1.4A Rated Motor: 1.4A Starting: 10A
ELECTRIC CONSUMPTION	Rated Motor: 240W (Power factor: 71%) Approx. 20kg (5mm)/22kg (15mm) (Ambient Temp.10°C, Water Temp.10°C) Approx. 17kg (5mm)/19kg (15mm) (Ambient Temp.21°C, Water Temp.15°C) Approx. 14kg (5mm)/16kg (15mm) (Ambient Temp.32°C, Water Temp.21°C)
ICE PRODUCTION PER 24h	Approx. 0.09m ³ (Ambient Temp.10°C, Water Temp.10°C) Approx. 0.05m ³ (Ambient Temp.21°C, Water Temp.15°C) Approx. 0.04m ³ (Ambient Temp.32°C, Water Temp.21°C)
WATER CONSUMPTION PER 24h	Approx. 0.09m ³ (Ambient Temp.10°C, Water Temp.10°C) Approx. 0.05m ³ (Ambient Temp.21°C, Water Temp.15°C) Approx. 0.04m ³ (Ambient Temp.32°C, Water Temp.21°C)
SHAPE OF ICE	Cube Approx. 28 x 28 x 32mm
FREEZE CYCLE TIME	Approx. 30min (Ambient Temp.21°C, Water Temp.15°C)
ICE PRODUCTION PER CYCLE	Approx. 0.4kg/18pcs. (Ambient Temp.21°C, Water Temp.15°C)
MAX STORAGE CAPACITY	Approx. 11.5kg (Bin Control Setting Approx. 6kg)
OUTSIDE DIMENSIONS	398mm (W) x 451mm (D) x 695mm (H)
EXTERIOR INSULATION	Stainless Steel, Galvanized Steel (Rear) Polyurethane Foam
INSULATION FOAM BLOWING AGENT	Water Blown
CONNECTIONS	X-Type Con. (with CONT. Plug)
CONNECTIONS - ELECTRIC	Inlet G3/4 (connected at rear side)
CONNECTIONS - WATER SUPPLY	Outlet R3/4 (connected at rear side)
CONNECTIONS-DRAIN	Cell type
ICE MAKING SYSTEM	Hot Gas Defrost
HARVESTING SYSTEM	Hermetic
COMPRESSOR	Fin and Tube type - Air-cooled
CONDENSER	320W (275kcal/h) (Ambient Temp.32°C, Water Temp.21°C)
HEAT REJECTION	Electroless nickel plated Copper Tube on Sheet and Cells
EVAPORATOR	Capillary Tube
REFRIGERANT CONTROL	RT 34a/110g
ICE MAKING CONTROL	Thermistor, Timer
HARVESTING CONTROL	Thermistor
BIN CONTROL	Microswitch (with Time Delay)
ICE MAKING WATER CONTROL	Timer, Water Pan's Movement
ELECTRICAL PROTECTION	Class I Appliance, 5A Fuse
COMPRESSOR PROTECTION	Auto-reset Overload Protector
ICE MAKER PROTECTION	Interlock by Controller Board
WEIGHT	34kg (Gross 39kg)
PACKAGE	Carton 505mm (W) x 575mm (D) x 862mm (H)
ACCESSORIES	Scoop, Installation Kit
OPERATING CONDITIONS	Ambient Temp.: 1 - 40°C, Water Supply Temp.: 5-35°C Water Supply Pressure: 0.07-0.8MPa (0.7-8bar) Voltage Range: Rated Voltage±6%

*We reserve the right to make changes in specifications and design without prior notice.

1. Install the product properly in accordance with the instructions on location, water supply/drain connections and electrical connections stated in the instruction and installation manuals provided. Allow 10mm extra space at the installation site to meet any installation requirements (additional spacing is also required for proper air flow and pipe connections).
2. The ice production depends on the ambient and water temperatures. Refer to the instruction manual.
3. Product Code: E1FA-D003

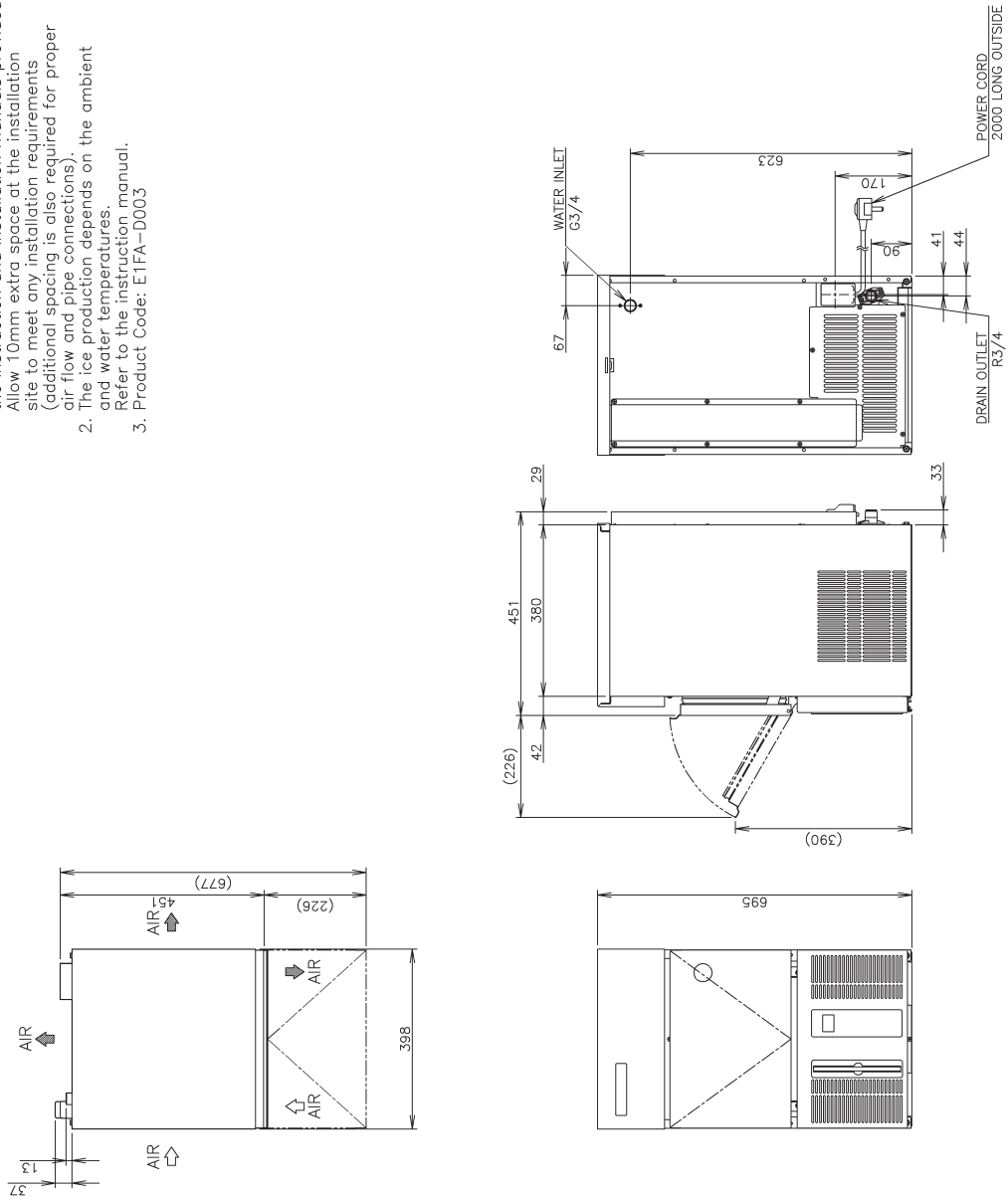

[b] IM-30CNE (Air-cooled)

1. Install the product properly in accordance with the instructions on location, water supply/drain connections and electrical connections stated in the instruction and installation manuals provided. Allow 10mm extra space at the installation site to meet any installation requirements (additional spacing is also required for proper air flow and pipe connections).
2. The ice production depends on the ambient and water temperatures. Refer to the instruction manual.
3. Product Code: E1FA

ITEM	Hoshizaki Cube Ice Maker
MODEL	IM-30CNE
POWER SUPPLY	1 PHASE 220-240V 50Hz Capacity: Min. 0.66kVA (2.8A)
AMPERAGE	Running: 1.7A Rated Motor: 1.7A Starting: 10A
ELECTRIC CONSUMPTION	Rated Motor: 270W (Power factor: 66%)
ICE PRODUCTION PER 24h	Approx. 23kg (6mm)/28kg (15mm) (Ambient Temp.10°C, Water Temp.10°C) Approx. 22kg (6mm)/24kg (15mm) (Ambient Temp.21°C, Water Temp.10°C) Approx. 18kg (6mm)/19kg (15mm) (Ambient Temp.32°C, Water Temp.21°C)
WATER CONSUMPTION PER 24h	Approx. 0.10m ³ (Ambient Temp.10°C, Water Temp.10°C) Approx. 0.06m ³ (Ambient Temp.21°C, Water Temp.15°C) Approx. 0.05m ³ (Ambient Temp.32°C, Water Temp.21°C)
SHAPE OF ICE	Cube Approx. 28 x 28 x 32mm
FREEZE CYCLE TIME PER CYCLE	Approx. 24min (Ambient Temp.21°C, Water Temp.15°C)
MAX STORAGE CAPACITY	Approx. 0.4kg/18pcs. (Ambient Temp.21°C, Water Temp.15°C)
OUTSIDE DIMENSIONS	Approx. 11.5kg (Bin Control Setting Approx. 6kg)
EXTERIOR	398mm (W) x 451mm (D) x 695mm (H)
INSULATION	Stainless Steel, Galvanized Steel (Rear)
INSULATION FOAM BLOWING AGENT	Polyurethane Foam
CONNECTIONS	Water Blown
CONNECTIONS - ELECTRIC	X-Type Con. (with CONT. Plug)
CONNECTIONS - WATER SUPPLY	Inlet G3/4 (connected at rear side)
CONNECTIONS - DRAIN	Outlet R3/4 (connected at rear side)
ICE MAKING SYSTEM	Cell type
HARVESTING SYSTEM	Hot Gas Defrost
COMPRESSOR	Hermetic
CONDENSER	Fin and Tube type, Air-cooled
HEAT REJECTION	430W (370kcal/h) (Ambient Temp.32°C, Water Temp.21°C)
EVAPORATOR	Electroless nickel plated Copper Tube on Sheet and Cells
REFRIGERANT CONTROL	Capillary Tube
REFRIGERANT CHARGE	R134a/130g
ICE MAKING CONTROL	Thermistor, Timer
HARVESTING CONTROL	Thermistor
BIN CONTROL	Microswitch (with Time Delay)
ICE MAKING WATER CONTROL	Timer, Water Pan's Movement
ELECTRICAL PROTECTION	Class I Appliance, 5A Fuse
COMPRESSOR PROTECTION	Auto-reset Overload Protector
ICE MAKER PROTECTION	Interlock by Controller Board
WEIGHT	34kg (Gross 39kg)
PACKAGE	Carton 505mm (W) x 575mm (D) x 862mm (H)
ACCESSORIES	Scoop, Leg. Installation Kit
OPERATING CONDITIONS	Ambient Temp.: 1-40°C, Water Supply Temp.: 5-35°C Water Supply Pressure: 0.07-0.8MPa (0.7-8bar) Voltage Range: Rated Voltage±6%

*We reserve the right to make changes in specifications and design without prior notice.

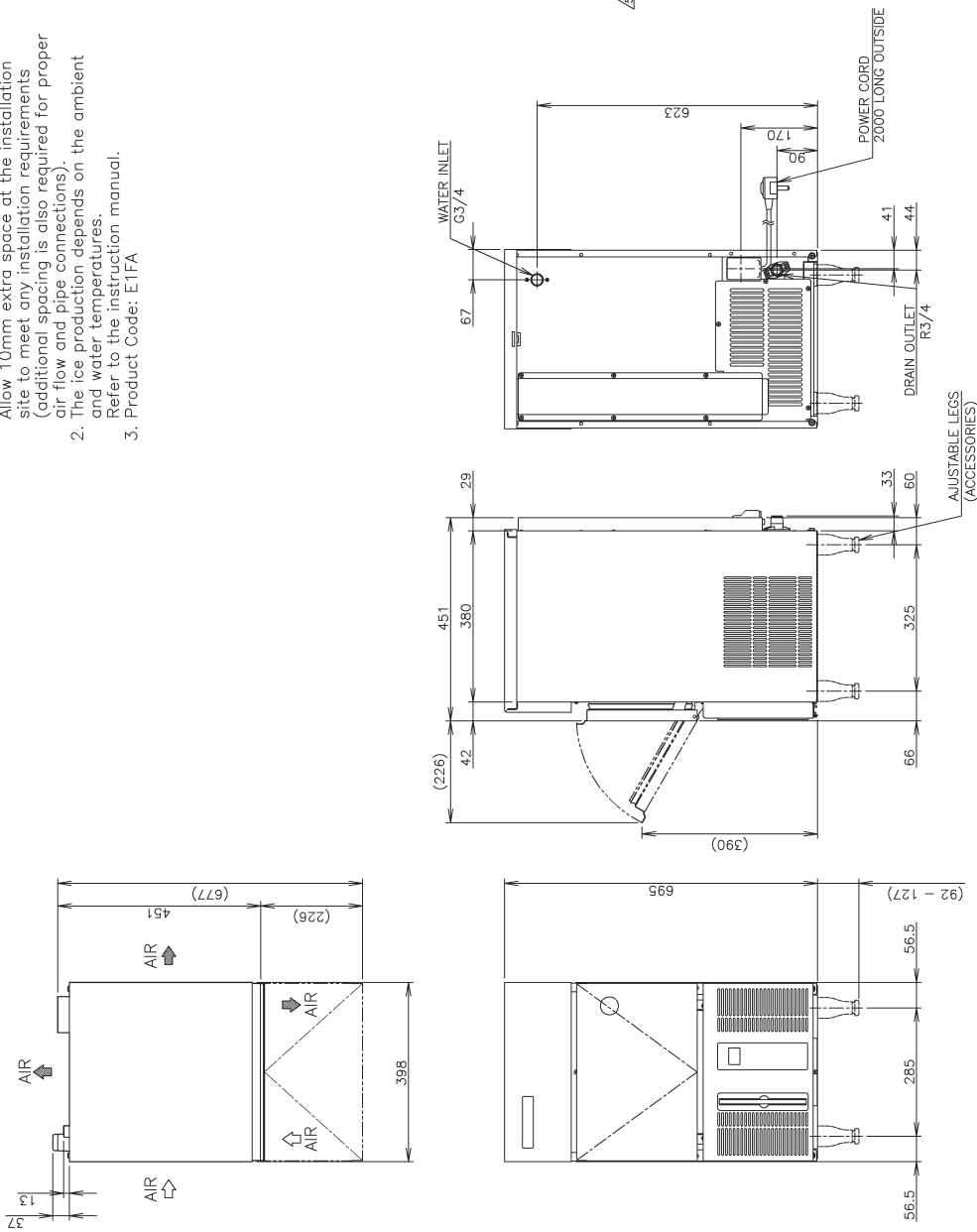

[c] IM-30CWNE (Water-cooled)

OPERATING CONDITIONS	Ambient Temp.: 1 – 40°C, Water Supply Temp.: 5–35°C Water Supply Pressure: 0.07–0.8MPa (0.7–8bar) Voltage Range: Rated Voltage±5%	ITEM	Hoshizaki Cube Ice Maker IM-30CWNE
	*We reserve the right to make changes in specifications and design without prior notice.	MODEL	IM-30CWNE
	1. Install the product properly in accordance with the instructions on location, water supply/drain connections and electrical connections stated in the instruction and installation manuals provided. Allow 10mm extra space at the installation site to meet any installation requirements (additional spacing is also required for proper air flow and pipe connections).	POWER SUPPLY	1 PHASE 220–240V 50Hz Capacity: Min. 0.66kVA (2.8A)
	2. The ice production depends on the ambient air flow and water temperatures.	AMPERAGE	Running: 1.2A Rated Motor: 1.2A Starting: 10A
	3. Product Code: E1FA-D002	ELECTRIC CONSUMPTION	Rated Motor: 190W (Power factor: 65%) Approx. 28kg (6mm)/23kg (15mm) (Ambient Temp.10°C, Water Temp.10°C) Approx. 28kg (6mm)/23kg (15mm) (Ambient Temp.21°C, Water Temp.15°C) Approx. 24kg (6mm)/20kg (15mm) (Ambient Temp.32°C, Water Temp.21°C)
		ICE PRODUCTION PER 24h	Approx. 0.12m ³ (Ambient Temp.10°C, Water Temp.10°C) Approx. 0.07m ³ (Ambient Temp.21°C, Water Temp.15°C) Approx. 0.06m ³ (Ambient Temp.32°C, Water Temp.21°C)
		WATER CONSUMPTION PER 24h	Approx. 0.06m ³ (Ambient Temp.21°C, Water Temp.15°C) Approx. 0.06m ³ (Ambient Temp.32°C, Water Temp.21°C)
		SHAPE OF ICE	Cube Approx. 28 x 28 x 32mm
		FREEZE CYCLE TIME	Approx. 20min (Ambient Temp.21°C, Water Temp.15°C)
		ICE PRODUCTION PER CYCLE	Approx. 0.4kg/18pcs. (Ambient Temp.21°C, Water Temp.15°C)
		MAX STORAGE CAPACITY	Approx. 11.5kg (Bin Control Setting Approx. 6kg)
		OUTSIDE DIMENSIONS	398mm (W) x 451mm (D) x 695mm (H)
		EXTERIOR	Stainless Steel, Galvanized Steel (Rear)
		INSULATION	Polyurethane Foam
		INSULATION FOAM BLOWING AGENT	Water Blown
		INSULATION FOAM BLOWING AGENT	X-Type Con. (with CONT. Plug)
		CONNECTIONS	- ELECTRIC Inlet G3/4 (connected at rear side)
		CONNECTIONS-IRRM	Outlet R3/4 (connected at rear side)
		CONNECTIONS	Inlet Rc1/2 (connected at rear side) -COOLING WATER Outlet Rc1/2 (connected at rear side)
		ICE MAKING SYSTEM	Cell type
		HARVESTING SYSTEM	Hot Gas Defrost
		COMPRESSOR	Hermetic
		CONDENSER	Tube-in-Tube Type, Water-cooled
		HEAT REJECTION	225W (195kcal/h) (Ambient Temp.32°C, Water Temp.21°C)
		EVAPORATOR	Electroless nickel plated Copper Tube on Sheet and Cells
		REFRIGERANT CONTROL	Thermostatic Expansion Valve
		REFRIGERANT CHARGE	R134a/180g
		ICE MAKING CONTROL	Thermistor, Timer
		HARVESTING CONTROL	Thermistor
		BIN CONTROL	Microswitch (with Time Delay)
		ICE MAKING WATER CONTROL	Timer, Water Pan's Movement
		ELECTRICAL PROTECTION	Class I Appliance, 5A Fuse
		COMPRESSOR PROTECTION	Auto-reset Overload Protector
		ICE MAKER PROTECTION	Interlock by Controller Board
		WEIGHT	35kg (Gross 41kg)
		PACKAGE	Carton 505mm (W) x 575mm (D) x 862mm (H)
		ACCESSORIES	Scoop, Leg. Installation Kit

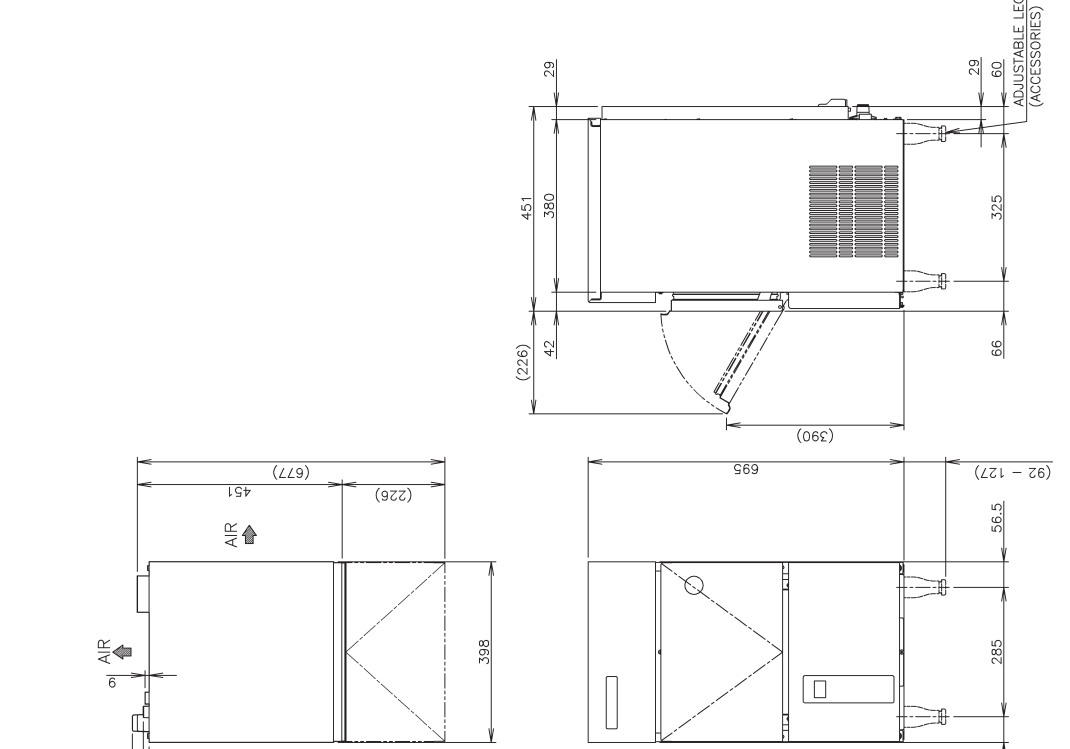

[f] IM-45WNE (Water-cooled)

OPERATING CONDITIONS	Ambient Temp.: 1 – 40° C, Water Supply Temp.: 5–35° C Water Supply Pressure: 0.07–0.8MPa (0.7–8bar) Voltage Range: Rated Voltage±6%	ITEM	Hoshizaki Cube Ice Maker
	*We reserve the right to make changes in specifications and design without prior notice.	MODEL	IM-45WNE
	1. Install the product properly in accordance with the instructions on location, water supply/drain connections and electrical connections stated in the instruction and installation manuals provided. Allow 10mm extra space at the installation site to meet any installation requirements (additional spacing is also required for proper air flow and pipe connections).	POWER SUPPLY	1 PHASE 220–240V 50Hz Capacity: Min. 0.86kVA (3.6A) Running: 2.1A Rated Motor: 2.1A Starting: 13A
	2. The ice production depends on the ambient and water temperatures. Refer to the instruction manual.	AMPERAGE	
	3. Product Code: E1FB-D002	ELECTRIC CONSUMPTION	Rated Motor: 295W (Power factor: 58%) Approx. 45kg (99lb)/47kg (105lb) (Ambient Temp.10° C, Water Temp.10° C) Approx. 38kg (84lb)/40kg (88lb) (Ambient Temp.21° C, Water Temp.10° C) Approx. 35kg (77lb)/37kg (82lb) (Ambient Temp.21° C, Water Temp.21° C) Approx. 0.22kWh (Ambient Temp.10° C, Water Temp.10° C) Approx. 0.12kWh (Ambient Temp.21° C, Water Temp.15° C) Approx. 0.11kWh (Ambient Temp.32° C, Water Temp.21° C)
		ICE PRODUCTION PER 24h	
		WATER CONSUMPTION PER 24h	
		SHAPE OF ICE	Cube Approx. 28 x 28 x 32mm
		FREEZE CYCLE TIME PER CYCLE	Approx. 24min (Ambient Temp. 21° C, Water Temp.15° C) Approx. 0.67kg/30pcs. (Ambient Temp. 21° C, Water Temp.15° C)
		MAX STORAGE CAPACITY	Approx. 18kg (Bin Control Setting Approx. 10kg)
		OUTSIDE DIMENSIONS	503mm (W) x 456mm (D) x 840mm (H)
		EXTERIOR	Stainless Steel, Galvanized Steel (Rear)
		INSULATION	Polyurethane Foam
		INSULATION FOAM BLOWING AGENT	Water Blown
		CONNECTIONS	X-Type Con. (with CONT. Plug)
		CONNECTIONS – WATER SUPPLY	Inlet G3/4 (connected at rear side)
		CONNECTIONS – DRAIN	Outlet R3/4 (connected at rear side)
		CONNECTIONS – COOLING WATER	Inlet Rc1/2 (connected at rear side)
		CONNECTIONS – COOLING WATER	Outlet Rc1/2 (connected at rear side)
		ICE MAKING SYSTEM	Cell type
		HARVESTING SYSTEM	Hot Gas Defrost
		COMPRESSOR	Hermetic
		CONDENSER	Tube and Tube type, Water-cooled
		HEAT REJECTION	360W (500kcal/h) (Ambient Temp.32° C, Water Temp.21° C)
		EVAPORATOR	Electroless nickel plated Copper Tube on Sheet and Cells
		REFRIGERANT CONTROL	Thermostatic Expansion Valve
		REFRIGERANT CHARGE	R134g/210g
		ICE MAKING CONTROL	Thermistor, Timer
		HARVESTING CONTROL	Thermistor
		BIN CONTROL	Microswitch (with Time Delay)
		ICE MAKING WATER CONTROL	Timer, Water Pan's Movement
		ELECTRICAL PROTECTION	Class I Appliance, 5A Fuse
		COMPRESSOR PROTECTION	Auto-reset Overload Protector
		ICE MAKER PROTECTION	Interlock by Controller Board
		WEIGHT	47kg (Gross 55kg)
		PACKAGE	Carton 635mm (W) x 520mm (D) x 1007mm (H)
		ACCESSORIES	Scoop, Leg, Installation Kit

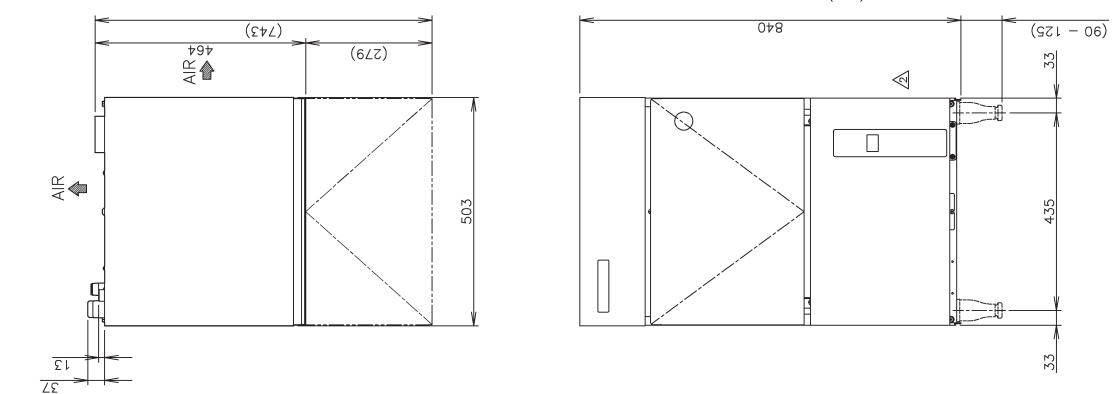
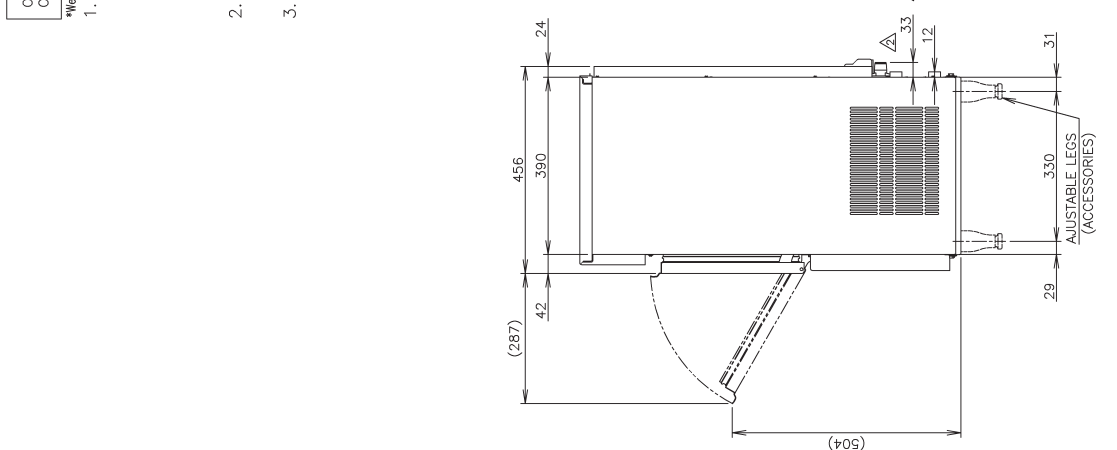
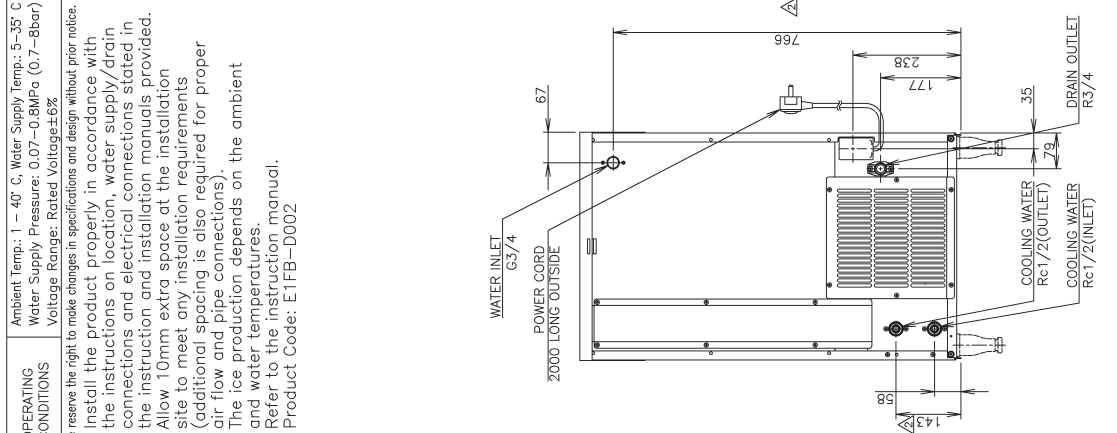

[h] IM-65WNE (Water-cooled)

OPERATING CONDITIONS	Ambient Temp.: 1 – 40° C, Water Supply Temp.: 5–35° C Water Supply Pressure: 0.07–0.8MPa (0.7–8bar) Voltage Range: Rated Voltage±6%	ITEM MODEL	Hoshizaki Cube Ice Maker IM – 65WNE
	<p>*We reserve the right to make changes in specifications and design without prior notice.</p> <p>1. Install the product properly in accordance with the instructions on location, water supply/drain connections and electrical connections stated in the instruction and installation manuals provided. Allow 10mm extra space at the installation site to meet any installation requirements (additional spacing is also required for proper air flow and pipe connections).</p> <p>2. The ice production depends on the ambient and water temperatures. Refer to the instruction manual.</p> <p>3. Product Code: E1FD–D002</p>		<p>POWER SUPPLY</p> <p>1 PHASE 220–240V 50Hz Capacity: Min. 0.99kVA (4.2A) Running: 2.5A Rated Motor: 2.5A Starting: 15A</p> <p>AMPERAGE</p> <p>ELECTRIC CONSUMPTION</p> <p>Rated Motor: 370W (Power factor: 61%) Approx. 53w (5mm)/63kg (15mm) (Ambient Temp.10° C, Water Temp.10° C) Approx. 46w (5mm)/58kg (15mm) (Ambient Temp.21° C, Water Temp.15° C) Approx. 44w (5mm)/52kg (15mm) (Ambient Temp.32° C, Water Temp.21° C)</p> <p>ICE PRODUCTION PER 24h</p> <p>WATER CONSUMPTION PER 24h</p> <p>Approx. 0.20m³ (Ambient Temp.10° C, Water Temp.10° C) Approx. 0.13m³ (Ambient Temp.21° C, Water Temp.15° C) Approx. 0.12m³ (Ambient Temp.32° C, Water Temp.21° C)</p> <p>SHAPE OF ICE CUBE</p> <p>Approx. 28 x 28 x 32mm</p> <p>FREEZE CYCLE TIME</p> <p>Approx. 27min (5s) (Ambient Temp.21° C, Water Temp.15° C)</p> <p>ICE PRODUCTION PER CYCLE</p> <p>Approx. 0.94kg/42ps.(5s) (Ambient Temp.21° C, Water Temp.15° C)</p> <p>MAX STORAGE CAPACITY</p> <p>Approx. 28kg (Bin Control Setting Approx. 18kg)</p> <p>OUTSIDE DIMENSIONS</p> <p>633mm (W) x 506mm (D) x 840mm (H)</p> <p>EXTERIOR</p> <p>Stainless Steel, Galvanized Steel (Rear)</p> <p>INSULATION</p> <p>Polyurethane Foam</p> <p>INSULATION FOAM BLOWING AGENT</p> <p>Water Blown</p> <p>CONNECTIONS – ELECTRIC</p> <p>X – Type Con. (with CONT. Plug)</p> <p>CONNECTIONS – WATER SUPPLY</p> <p>Inlet G3/4 (connected at rear side)</p> <p>CONNECTIONS – DRAIN</p> <p>Outlet R3/4 (connected at rear side)</p> <p>CONNECTIONS – COOLING WATER</p> <p>Inlet Rc1/2 (connected at left side) Outlet Rc1/2 (connected at left side)</p> <p>ICE MAKING SYSTEM</p> <p>Cell type</p> <p>HARVESTING SYSTEM</p> <p>Hot Gas Defrost</p> <p>COMPRESSOR</p> <p>Hermetic</p> <p>CONDENSER</p> <p>Tube and Tube type, Water-cooled</p> <p>HEAT REJECTION</p> <p>770W (660kcal/h) (Ambient Temp.32° C, Water Temp.21° C)</p> <p>EVAPORATOR</p> <p>Electroless nickel plated Copper Tube on Sheet and Cells</p> <p>REFRIGERANT CONTROL</p> <p>Capillary Tube</p> <p>REFRIGERANT CHARGE</p> <p>R134c/250g</p> <p>ICE MAKING CONTROL</p> <p>Thermistor, Timer</p> <p>HARVESTING CONTROL</p> <p>Thermistor</p> <p>BIN CONTROL</p> <p>Microswitch (with Time Delay)</p> <p>ICE MAKING WATER CONTROL</p> <p>Timer, Water Pan's Movement</p> <p>ELECTRICAL PROTECTION</p> <p>Class I Appliance, 5A Fuse</p> <p>COMPRESSOR PROTECTION</p> <p>Auto-reset Overload Protector</p> <p>ICE MAKER PROTECTION</p> <p>Interlock by Controller Board</p> <p>WEIGHT</p> <p>54kg (Gross 64kg)</p> <p>PACKAGE</p> <p>Carton 735mm (W) x 570mm (D) x 1012mm (H)</p> <p>ACCESSORIES</p> <p>Scoop, Installation Kit, Ice Chute</p>

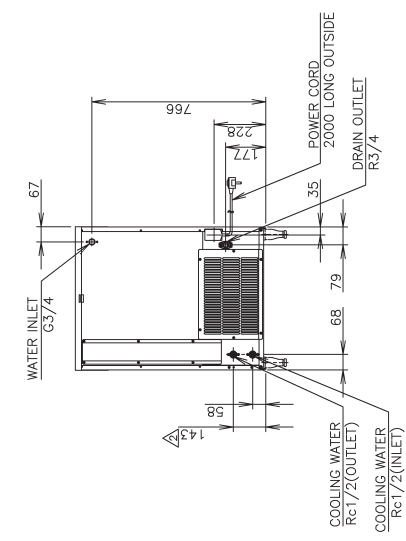
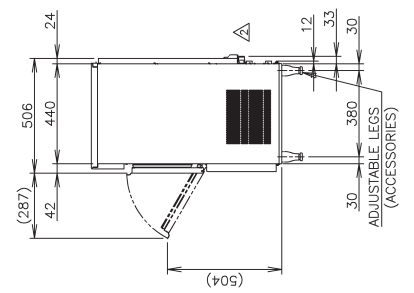
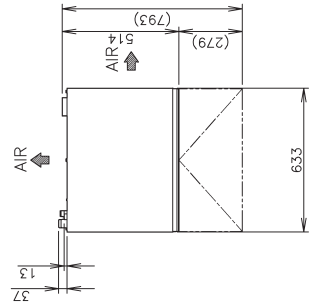

[i] IM-100CNE (Air-cooled)

OPERATING CONDITIONS	Ambient Temp. : 1 – 40° C, Water Supply Temp. : 5–35° C Water Supply Pressure: 0.07–0.8MPa (0.7–8bar) Voltage Range: Rated Voltage±6%	ITEM	Hoshizaki Cube Ice Maker
	*We reserve the right to make changes in specifications and design without prior notice.	MODEL	IM-100CNE
	1. Install the ice maker properly in accordance with the instructions on location, water supply/drain connections and electrical connections stated in the instruction and installation manuals provided. Allow 10mm extra space at the installation site to meet any installation requirements (additional spacing is also required for proper air flow and pipe connections).	POWER SUPPLY	1 PHASE 220–240V 50Hz Capacity: Min. 1.28kVA (S.5A) Running: 4.1A Rated Motor: 4.1A Starting: 19A
	2. The ice production depends on the ambient and water temperatures. Refer to the instruction manual.	AMPERAGE	
	3. Product Code: E1FE-D010	ELECTRIC CONSUMPTION	Rated Motor: 630W (Power factor: 64%) Approx. 85kg (5mm)/95kg (15mm) (Ambient Temp.10° C, Water Temp.10° C) Approx. 63kg (5mm)/93kg (15mm) (Ambient Temp.21° C, Water Temp.15° C) Approx. 23kg (5mm)/93kg (15mm) (Ambient Temp.32° C, Water Temp.21° C) Approx. 0.42m ³ (Ambient Temp.10° C, Water Temp.10° C) Approx. 0.20m ³ (Ambient Temp.21° C, Water Temp.15° C) Approx. 0.16m ³ (Ambient Temp.32° C, Water Temp.21° C)
		ICE PRODUCTION PER 24h	
		WATER CONSUMPTION PER 24h	
		SHAPE OF ICE	Cube Approx. 28 x 28 x 32mm
		FREEZE CYCLE TIME PER CYCLE	Approx. 29min (5*) (Ambient Temp. 21° C, Water Temp. 15° C)
		MAX STORAGE CAPACITY	Approx. 1.8kg/80pcs. (5*) (Ambient Temp. 21° C, Water Temp. 15° C)
		OUTSIDE DIMENSIONS	Approx. 38kg (Bin Control Setting Approx. 23kg)
		EXTERIOR	1004mm (W) x 600mm (D) x 800 (790 – 830)mm (H)
		INSULATION	Stainless Steel, Galvanized Steel (Rear)
		INSULATION FOAM BLOWING AGENT	Polyurethane Foam
		CONNECTIONS – ELECTRIC	Water Blown
		CONNECTIONS – WATER SUPPLY	X-Type Con. (with CONT. Plug)
		CONNECTIONS – DRAIN	Inlet G3/4 (connected at rear side)
		ICE MAKING SYSTEM	Outlet Rc3/4 (connected at bottom)
		HARVESTING SYSTEM	Cell type
		COMPRESSOR	Hot Gas Defrost
		CONDENSER	Hermetic
		EVAPORATOR	Air-cooled
		REFRIGERANT CONTROL	180W (1015kcal/h) (Ambient Temp. 32° C, Water Temp. 21° C)
		ICE MAKING CONTROL	Electroless nickel plated Copper Tube on Sheet and Cells
		BIN CONTROL	Thermistor, Timer
		WATER CONTROL	Thermistor
		ELECTRICAL PROTECTION	Microswitch (with Time Delay)
		COMPRESSOR PROTECTION	Timer, Water Pan's Movement
		ICE MAKER PROTECTION	Class I Appliance, 5A Fuse
		LEG	Auto-reset Overload Protector
		WEIGHT	Interlock by Controller Board
		PACKAGE	Plastic Adjustable from 90 to 130mm
		ACCESSORIES	77kg (Gross 88kg) Carton 1110mm (W) x 700mm (D) x 875mm (H) Scoop, Installation Kit

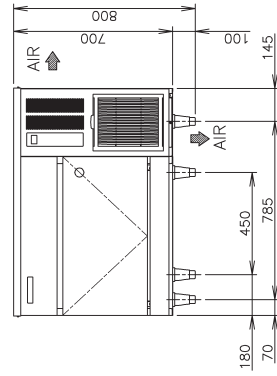
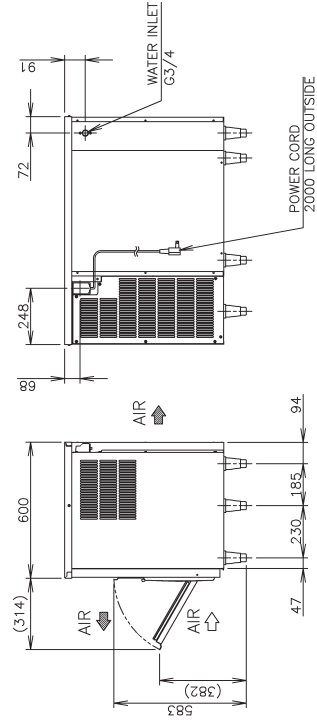
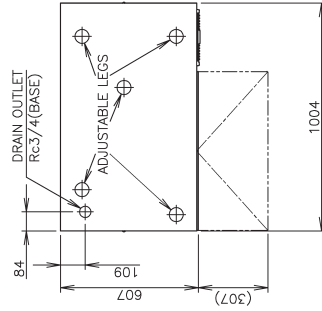

[J] IM-100NE (Air-cooled)

1. Install the ice maker properly in accordance with the instructions on location, water supply/drain connections and electrical connections stated in the instruction and installation manuals provided. Allow 10mm extra space at the installation site to meet any installation requirements (additional spacing is also required for proper air flow and pipe connections).
2. The ice production depends on the ambient and water temperatures. Refer to the instruction manual.
3. Product Code: E1FE

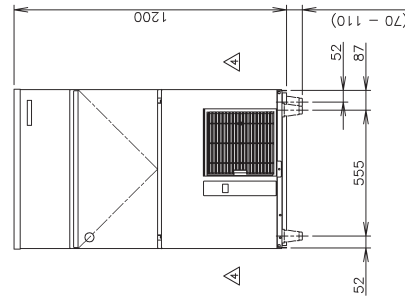
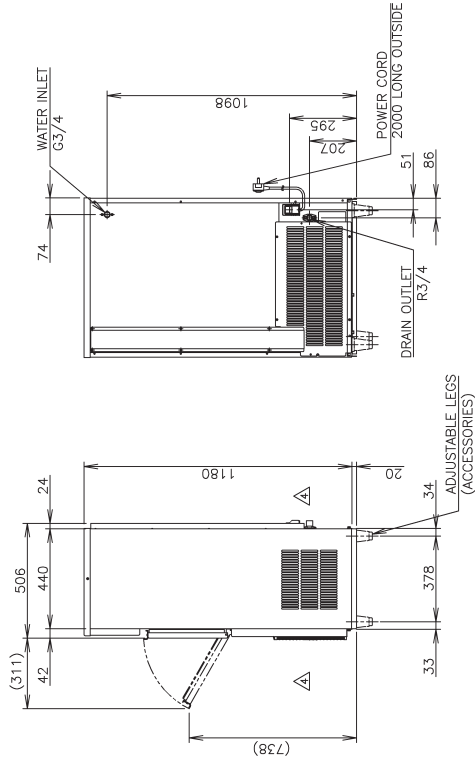
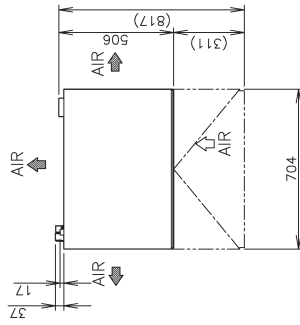

ITEM	Hoshizaki Cube Ice Maker
MODEL	IM-100NE
POWER SUPPLY	1 PHASE 220-240V 50Hz Capacity: Min. 1.25kVA (5.5A)
AMPERAGE	Running: 4.1A Rated Motor: 4.1A Starting: 19A
ELECTRIC CONSUMPTION	Rated Motor: 630W (Power factor: 64%)
ICE PRODUCTION PER 24h	Approx. 85kg (6mm)/95kg (5mm) (Ambient Temp.10° C, Water Temp.10° C) Approx. 83kg (5mm)/93kg (5mm) (Ambient Temp.21° C, Water Temp.15° C) Approx. 73kg (5mm)/84kg (5mm) (Ambient Temp.32° C, Water Temp.21° C)
WATER CONSUMPTION PER 24h	Approx. 0.45m ³ (Ambient Temp.10° C, Water Temp.10° C) Approx. 0.21m ³ (Ambient Temp.21° C, Water Temp.15° C) Approx. 0.18m ³ (Ambient Temp.32° C, Water Temp.21° C)
SHAPE OF ICE	Cube Approx. 28 x 28 x 32mm
FREEZE CYCLE TIME PER CYCLE	Approx. 28min (5#) (Ambient Temp.21° C, Water Temp.15° C) Approx. 1.8kg/80pcs. (5#) (Ambient Temp.21° C, Water Temp.15° C)
MAX STORAGE CAPACITY	Approx. 50kg (Bin Control Setting Approx. 28kg)
OUTSIDE DIMENSIONS	704mm (W) x 506mm (D) x 1200mm (H)
EXTERIOR INSULATION	Stainless Steel, Galvanized Steel (Rear) Polyurethane Foam
INSULATION BLOWING AGENT	Water Blown
CONNECTIONS	X-Type Con. (with CONT. Plug)
CONNECTIONS - WATER SUPPLY	Inlet G3/4 (connected at rear side)
CONNECTIONS-DRAIN	Outlet R3/4 (connected at rear side)
ICE MAKING SYSTEM	Cell type
HARVESTING SYSTEM	Hot Gas Defrost
COMPRESSOR	Hermetic
CONDENSER	Air-cooled
HEAT REJECTION	1180W (1015cal/h) (Ambient Temp.32° C, Water Temp.21° C)
EVAPORATOR	Electroless nickel plated Copper Tube on Sheet and Cells
REFRIGERANT CONTROL	Thermostatic Expansion Valve
REFRIGERANT CHARGE	R134a/290g
ICE MAKING CONTROL	Thermistor, Timer
HARVESTING CONTROL	Thermistor
BIN CONTROL	Microswitch (with Time Delay)
ICE MAKING WATER CONTROL	Timer, Water Pan's Movement
ELECTRICAL PROTECTION	Class I Appliance, 5A Fuse
COMPRESSOR PROTECTION	Auto-reset Overload Protector
ICE MAKER PROTECTION	Interlock by Controller Board
WEIGHT	76kg (Gross 85kg)
PACKAGE	Carton 805mm (W) x 880mm (D) x 1375mm (H)
ACCESSORIES	Scoop, Leg, Installation Kit
OPERATING CONDITIONS	Ambient Temp.: 1 - 40° C, Water Supply Temp.: 5-35° C Water Supply Pressure: 0.07-0.8MPa (0.7-8bar) Voltage Range: Rated Voltage±10%

*We reserve the right to make changes in specifications and design without prior notice.

[I] IM-130NE (Air-cooled)

1. Install the ice maker properly in accordance with the instructions on location, water supply/drain connections and electrical connections stated in the instruction and installation manuals provided. Allow 10mm extra space at the installation site to meet any installation requirements (additional spacing is also required for proper air flow and pipe connections).
2. The ice production depends on the ambient and water temperatures. Refer to the instruction manual.
3. Product Code: E1FF

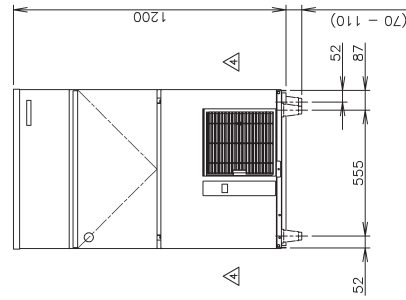
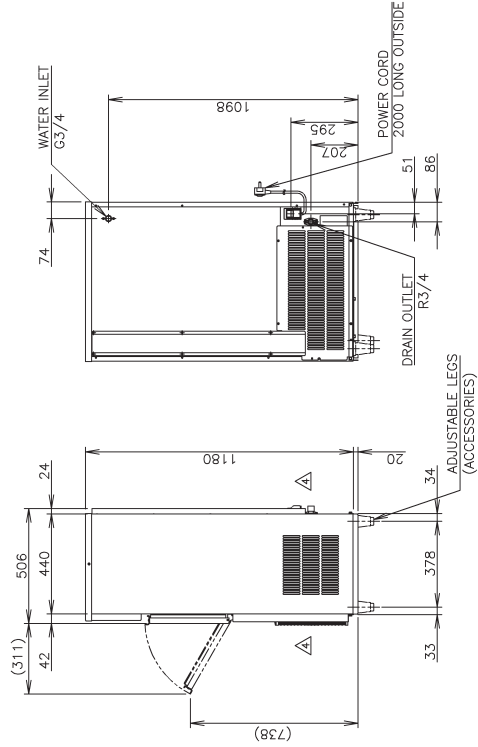
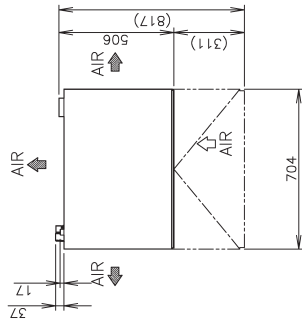

ITEM	Hoshizaki: Cube Ice Maker
MODEL	IM-130NE
POWER SUPPLY	1 PHASE 220-240V 50Hz Capacity: Min. 1.25kVA (5.5A)
AMPERAGE	Running: 4.5A Rated Motor: 4.5A Starting: 19A
ELECTRIC CONSUMPTION	Rated Motor: 700W (Power factor: 64%)
ICE PRODUCTION PER 24h	Approx. 100kg (5mm)/20kg (15mm) (Ambient Temp.10° C, Water Temp.10° C) Approx. 104kg (5mm)/107kg (15mm) (Ambient Temp.21° C, Water Temp.15° C) Approx. 88kg (5mm)/91kg (15mm) (Ambient Temp.32° C, Water Temp.21° C)
WATER CONSUMPTION PER 24h	Approx. 0.53m ³ (Ambient Temp.10° C, Water Temp.10° C) Approx. 0.26m ³ (Ambient Temp.21° C, Water Temp.15° C) Approx. 0.22m ³ (Ambient Temp.32° C, Water Temp.21° C)
SHAPE OF ICE	Cube Approx. 28 x 28 x 32mm
FREEZE CYCLE TIME PER CYCLE	Approx. 22min (5*) (Ambient Temp.21° C, Water Temp.15° C)
MAX STORAGE CAPACITY	Approx. 1.8kg/80pcs. (5*) (Ambient Temp.21° C, Water Temp.15° C)
OUTSIDE DIMENSIONS	Approx. 50kg (Bin Control Setting Approx. 28kg)
EXTERIOR	704mm (W) x 506mm (D) x 1200mm (H)
INSULATION	Stainless Steel, Galvanized Steel (Rear) Polyurethane Foam
INSULATION FOAM BLOWING AGENT	Water Blown
CONNECTIONS - ELECTRIC	X-Type Con. (with CONT. Plug)
CONNECTIONS - WATER SUPPLY	Inlet G3/4 (connected at rear side)
CONNECTIONS-DRAIN	Outlet R3/4 (connected at rear side)
ICE MAKING SYSTEM	Cell type
HARVESTING SYSTEM	Hot Gas Defrost
COMPRESSOR	Hermetic
CONDENSER	Air-cooled
HEAT REJECTION	1880W (103kcal/h) (Ambient Temp.32° C, Water Temp.21° C)
EVAPORATOR	Electroless nickel plated Copper Tube on Sheet and Cells
REFRIGERANT CONTROL	Thermostatic Expansion Valve
REFRIGERANT CHARGE	R404A/380g
ICE MAKING CONTROL	Thermistor, Timer
HARVESTING CONTROL	Thermistor
BIN CONTROL	Microswitch (with Time Delay)
ICE MAKING WATER CONTROL	Timer, Water Pan's Movement
ELECTRICAL PROTECTION	Class I Appliance, 5A Fuse
COMPRESSOR PROTECTION	Auto-reset Overload Protector
ICE MAKER PROTECTION	Interlock by Controller Board
WEIGHT	76kg (Gross 85kg)
PACKAGE	Carton 805mm (W) x 580mm (D) x 1375mm (H)
ACCESSORIES	Scoop, Leg, Installation Kit
OPERATING CONDITIONS	Ambient Temp: 1 - 40° C, Water Supply Temp: 5-35° C Water Supply Pressure: 0.07-0.8MPa (0.7-8bar) Voltage Range: Rated Voltage±6%

We reserve the right to make changes in specifications and design without prior notice.

[m] IM-130WNE (Water-cooled)

OPERATING CONDITIONS	Ambient Temp.: 1 – 40° C, Water Supply Temp.: 5–35° C Water Supply Pressure: 0.07–0.8MPa (0.7–8bar) Voltage Range: Rated Voltage±6%	ITEM	Hoshizaki Cube Ice Maker
	<p>We reserve the right to make changes in specifications and design without prior notice.</p> <ol style="list-style-type: none"> 1. Install the ice maker properly in accordance with the instructions on location, water supply/drain connections and electrical connections stated in the instruction and installation manuals provided. Allow 10mm extra space at the installation site to meet any installation requirements (additional spacing is also required for proper air flow and pipe connections). 2. The ice production depends on the ambient and water temperatures. Refer to the instruction manual. 3. Product Code: E1FF–D002 		MODEL
		POWER SUPPLY	1 PHASE 220–240V 50Hz Capacity: Min. 1.32kVA (5.6A)
		AMPERAGE	Running: 4.2A Rated Motor: 4.2A Starting: 19A
		ELECTRIC CONSUMPTION	Rated Motor: 640W (Power factor: 63%)
		ICE PRODUCTION PER 24h	Approx. 110kg (5mm)/122kg (15mm) (Ambient Temp. 10° C, Water Temp. 10° C) Approx. 105kg (5mm)/112kg (15mm) (Ambient Temp. 21° C, Water Temp. 15° C) Approx. 95kg (5mm)/105kg (15mm) (Ambient Temp. 32° C, Water Temp. 21° C)
		WATER CONSUMPTION PER 24h	Approx. 0.56m ³ (Ambient Temp. 10° C, Water Temp. 10° C) Approx. 0.26m ³ (Ambient Temp. 21° C, Water Temp. 15° C) Approx. 0.23m ³ (Ambient Temp. 32° C, Water Temp. 21° C)
		SHAPE OF ICE	Cube Approx. 28 x 28 x 32mm
		FREEZE CYCLE TIME PER CYCLE	Approx. 22min (5#) (Ambient Temp. 21° C, Water Temp. 15° C) Approx. 1.8kg/80pcs. (5#) (Ambient Temp. 21° C, Water Temp. 15° C)
		MAX STORAGE CAPACITY	Approx. 50kg (Bin Control Setting Approx. 28kg)
		OUTSIDE DIMENSIONS	704mm (W) x 506mm (D) x 1200mm (H)
		EXTERIOR	Stainless Steel, Galvanized Steel (Rear)
		INSULATION	Polyurethane Foam
		INSULATION FOAM BLOWING AGENT	Water Blown
		CONNECTIONS – ELECTRIC	X–Type Con. (with CONT. Plug)
		CONNECTIONS – WATER SUPPLY	Inlet G3/4 (connected at rear side)
		CONNECTIONS–DRAIN	Outlet R3/4 (connected at rear side)
		CONNECTIONS – COOLING WATER	Inlet Rc1/2 (connected at left side) Outlet Rc1/2 (connected at left side)
		ICE MAKING SYSTEM	Cell type
		HARVESTING SYSTEM	Hot Gas Defrost
		COMPRESSOR	Hermetic
		CONDENSER	Tube and Tube type, Water-cooled
		HEAT REJECTION	1500W (1290kcal/h) (Ambient Temp. 32° C, Water Temp. 21° C)
		EVAPORATOR	Electroless nickel plated Copper Tube on Sheet and Cells
		REFRIGERANT CONTROL	Thermostatic Expansion Valve
		REFRIGERANT CHARGE	R404A/450g
		ICE MAKING CONTROL	Thermistor, Timer
		HARVESTING CONTROL	Thermistor
		BIN CONTROL	Microswitch (with Time Delay)
		ICE MAKING WATER CONTROL	Timer, Water Pan's Movement
		ELECTRICAL PROTECTION	Class I Appliance, 5A Fuse
		COMPRESSOR PROTECTION	Auto–reset Overload Protector
		ICE MAKER PROTECTION	Interlock by Controller Board
		WEIGHT	74kg (Gross 84kg)
		PACKAGE	Carton 805mm (W) x 580mm (D) x 1375mm (H)
		ACCESSORIES	Scoop, Leg, Installation Kit

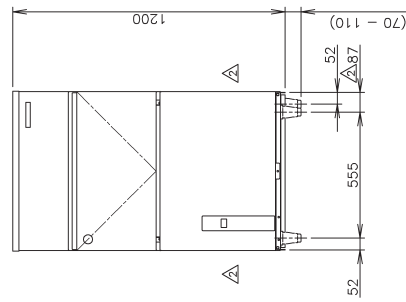
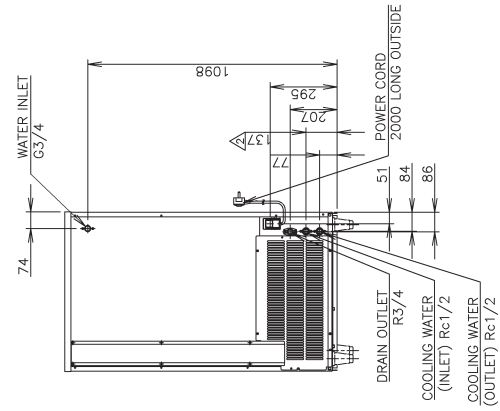
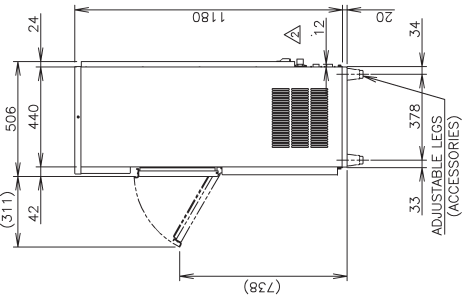
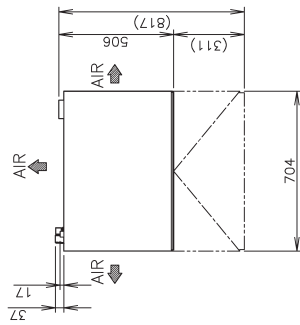

[n] IM-240NE (Air-cooled)

1. Install the product properly in accordance with the instructions on location, water supply/drain connections and electrical connections stated in the instruction manual provided.
Allow 10mm extra space at the installation site to meet any installation requirements (additional spacing is also required for proper air flow and pipe connections).
2. The ice production depends on the ambient and water temperatures.
Refer to the instruction manual.
3. Product Code: E1EC
(Auxiliary code: B-1 and later)

ITEM	Hoshizaki Cube Ice Maker
MODEL	IM-240NE
POWER SUPPLY	1 PHASE 220-240V 50Hz Capacity: Min. 2.3kVA (9.6A)
AMPERAGE	Running: 6.6A Rated Motor: 6.6A Starting: 35A
ELECTRIC CONSUMPTION	Rated Motor: 1320W (Power factor: 83%)
ICE PRODUCTION PER 24h	Approx. 220kg (6mm)/240kg (15mm) (Ambient Temp.10° C, Water Temp.10° C) Approx. 205kg (6mm)/220kg (15mm) (Ambient Temp.21° C, Water Temp.15° C) Approx. 180kg (6mm)/190kg (15mm) (Ambient Temp.32° C, Water Temp.21° C)
WATER CONSUMPTION PER 24h	Approx. 0.76m ³ (Ambient Temp.10° C, Water Temp.10° C) Approx. 0.36m ³ (Ambient Temp.21° C, Water Temp.15° C) Approx. 0.34m ³ (Ambient Temp.32° C, Water Temp.21° C)
SHAPE OF ICE	Cube Approx. 28 x 28 x 32mm
FREEZE CYCLE TIME PER CYCLE	Approx. 20min (Ambient Temp.21° C, Water Temp.15° C)
ICE PRODUCTION PER CYCLE	Approx. 3.2kg /140pcs (Ambient Temp.21° C, Water Temp.15° C)
MAX STORAGE CAPACITY	Approx. 110kg (Bin Control Setting Approx. 80kg)
OUTSIDE DIMENSIONS	704mm(W) x 665mm(D) x 1510mm(H)
EXTERIOR	Stainless Steel, Galvanized Steel (Rear)
INSULATION	Polyurethane Foam
INSULATION BLOWING AGENT	Water Blown
CONNECTIONS - ELECTRIC	X-Type Con. (with CONT. Plug)
CONNECTIONS - WATER SUPPLY	Inlet G3/4 (connected at rear side)
CONNECTIONS-DRAIN	Outlet R3/4 (connected at rear side)
ICE MAKING SYSTEM	Cell type
HARVESTING SYSTEM	Hot Gas Defrost
COMPRESSOR	Hermetic
CONDENSER	Fin and Tube type, Air-cooled
HEAT REJECTION	2870W (2470kcal/h) (Ambient Temp.32° C, Water Temp.21° C)
EVAPORATOR	Electroless nickel plated Copper Tube on Sheet and Cells
REFRIGERANT CONTROL	Thermostatic Expansion Valve
REFRIGERANT CHARGE	R404A/500g
ICE MAKING CONTROL	Thermistor, Timer
HARVESTING CONTROL	Thermistor
BIN CONTROL	Microswitch (with Time Delay)
ICE MAKING WATER CONTROL	Timer, Water Pan's Movement
ELECTRICAL PROTECTION	Class I Appliance, 5A Fuse
COMPRESSOR PROTECTION	Auto-reset Overload Protector
ICE MAKER PROTECTION	Interlock by Controller Board
WEIGHT	111kg (Gross 128kg)
PACKAGE	Carton 805mm(W) x 760mm(D) x 1684mm(H)
ACCESSORIES	Scoop, Leg, Installation Kit
OPERATING CONDITIONS	Ambient Temp.: 1 - 40° C, Water Supply Temp.: 5-35° C Water Supply Pressure: 0.07-0.8MPa (0.7-8bar) Voltage Range: Rated Voltage±6%

We reserve the right to make changes in specifications and design without prior notice.

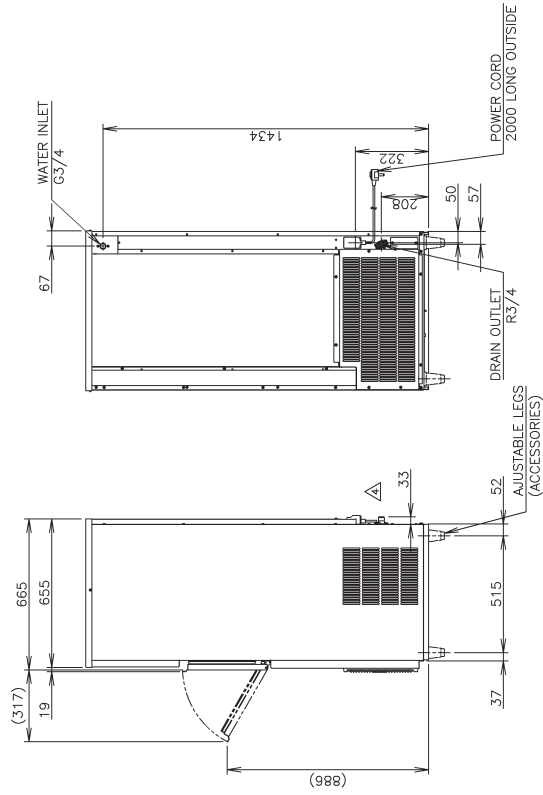
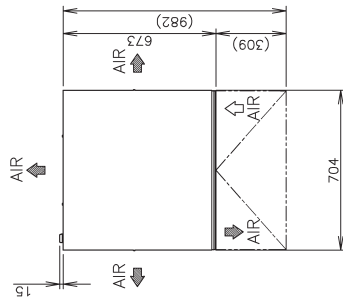

[o] IM-240WNE (Water-cooled)

OPERATING CONDITIONS	Ambient Temp.: 1 – 40° C, Water Supply Temp.: 5–35° C Water Supply Pressure: 0.07–0.8MPa (0.7–8bar) Voltage Range: Rated Voltage±6%	ITEM	Hoshizaki Cube Ice Maker
	We reserve the right to make changes in specifications and design without prior notice.	MODEL	IM-240WNE
	1. Install the product properly in accordance with the instructions on location, water supply/drain connections and electrical connections stated in the instruction manual provided. Allow 10mm extra space at the installation site to meet any installation requirements (additional spacing is also required for proper air flow and pipe connections). 2. The ice production depends on the ambient and water temperatures. Refer to the instruction manual. 3. Product Code: E1EC-D003 (Auxiliary code: B-1 and later)	POWER SUPPLY	1 PHASE 220–240V 50Hz Capacity: Min. 2.3kVA (9.6A) Running: 6.3A Rated Motor: 6.3A Starting: 35A
		AMPERAGE	
		ELECTRIC CONSUMPTION	Rated Motor: 1300W (Power factor: 85%)
		ICE PRODUCTION PER 24h	Approx. 230kg (50mm/240kg (15mm) (Ambient Temp. 10° C, Water Temp. 10° C) Approx. 215kg (50mm)/225kg (15mm) (Ambient Temp. 21° C, Water Temp. 15° C) Approx. 205kg (50mm)/215kg (15mm) (Ambient Temp. 32° C, Water Temp. 21° C)
		WATER CONSUMPTION PER 24h	Approx. 0.76m ³ (Ambient Temp. 10° C, Water Temp. 10° C) Approx. 0.37m ³ (Ambient Temp. 21° C, Water Temp. 15° C) Approx. 0.36m ³ (Ambient Temp. 32° C, Water Temp. 21° C)
		SHAPE OF ICE	Cube Approx. 28 x 28 x 23mm
		FREEZE CYCLE TIME PER CYCLE	Approx. 19min (Ambient Temp. 21° C, Water Temp. 15° C)
		MAX STORAGE CAPACITY	Approx. 3.2kg/140pcs (Ambient Temp. 21° C, Water Temp. 15° C)
		OUTSIDE DIMENSIONS	Approx. 110kg (Bin Control Setting Approx. 80kg)
		EXTERIOR	704mm(W) x 665mm(D) x 1510mm(H)
		INSULATION	Stainless Steel, Galvanized Steel (Rear)
		INSULATION FOAM BLOWING AGENT	Polyurethane Foam
		CONNECTIONS – ELECTRIC	Water Blown X-Type Con. (with CONT. Plug)
		CONNECTIONS – WATER SUPPLY	Inlet G3/4 (connected at rear side)
		CONNECTIONS – DRAIN	Outlet R3/4 (connected at rear side)
		CONNECTIONS – COOLING WATER	Inlet Rc1/2 (connected at left side) Outlet Rc1/2 (connected at left side)
		ICE MAKING SYSTEM	Cell type
		HARVESTING SYSTEM	Hot Gas Defrost
		COMPRESSOR	Hermetic
		CONDENSER	Tube in Tube Type, Water-Cooled
		HEAT REJECTION	2850W (2450kcal/h) (Ambient Temp. 32° C, Water Temp. 21° C)
		EVAPORATOR	Electroless nickel plated Copper Tube on Sheet and Cells
		REFRIGERANT CONTROL	Thermostatic Expansion Valve
		REFRIGERANT CHARGE	R404A/450g
		ICE MAKING CONTROL	Thermistor, Timer
		HARVESTING CONTROL	Thermistor
		BIN CONTROL	Microswitch (with Time Delay)
		ICE MAKING WATER CONTROL	Timer, Water Pan's Movement
		ELECTRICAL PROTECTION	Class I Appliance, 5A Fuse
		COMPRESSOR PROTECTION	Auto-reset Overload Protector
		ICE MAKER PROTECTION	Interlock by Controller Board
		WEIGHT	120kg (Gross 127kg)
		PACKAGE	Carton 805mm(W) x 760mm(D) x 1684mm(H)
		ACCESSORIES	Scoop, Leg, Installation Kit

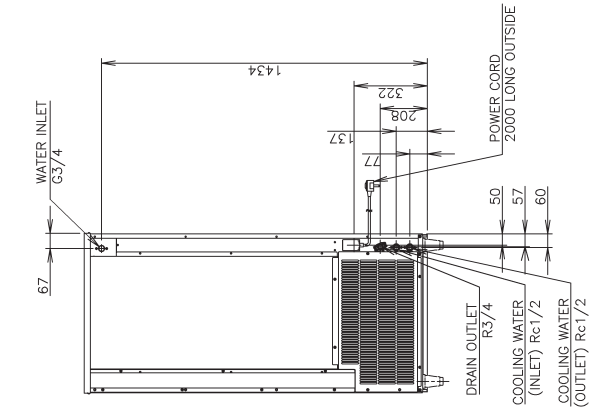
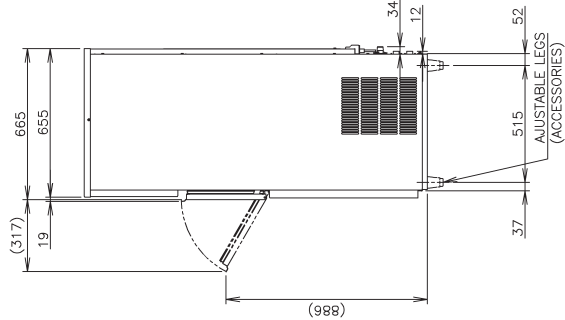
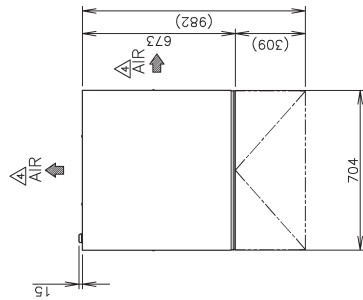

II. GENERAL INFORMATION

1. CONSTRUCTION

[a] IM-21CNE, IM-30CNE (Air-cooled)

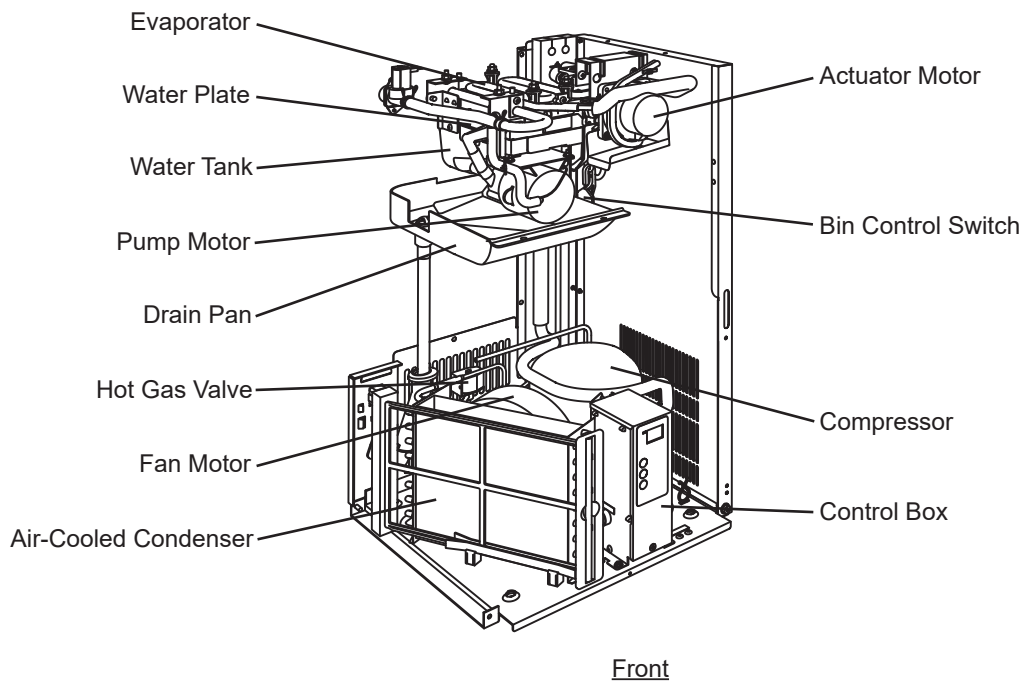
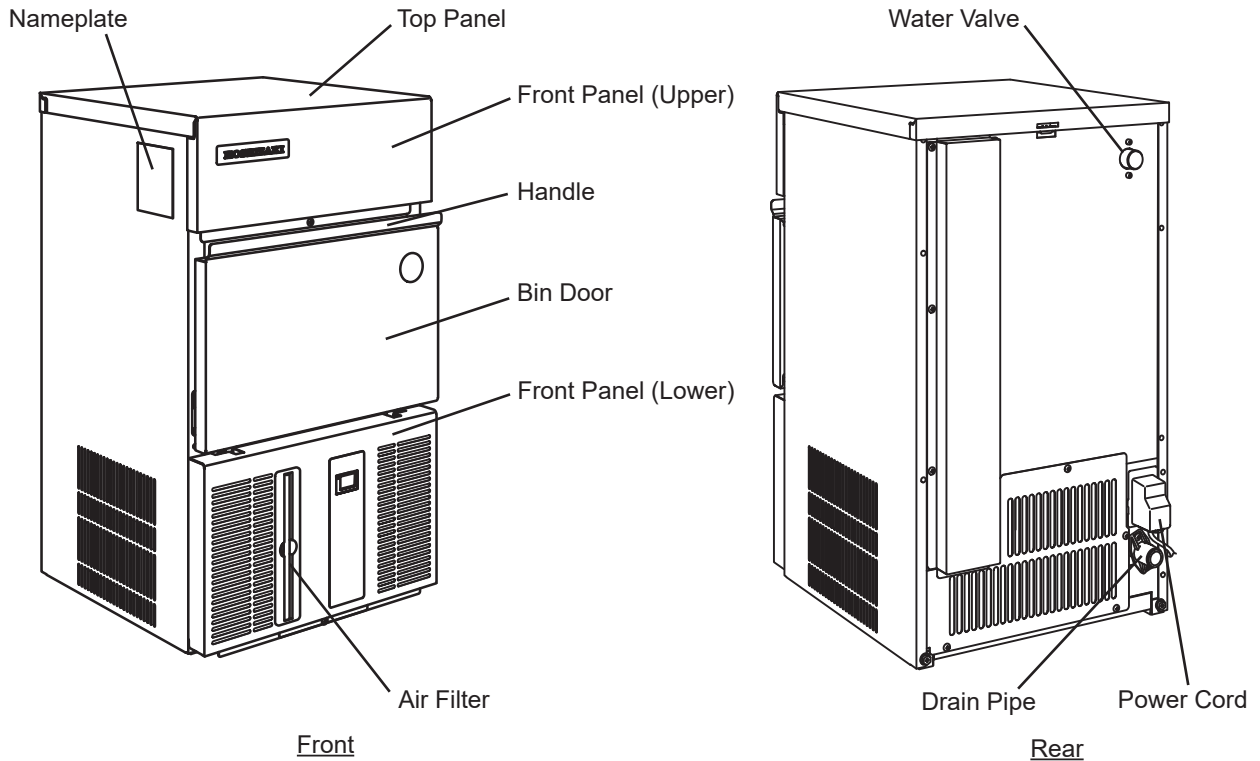

[b] IM-30CWNE (Water-cooled)

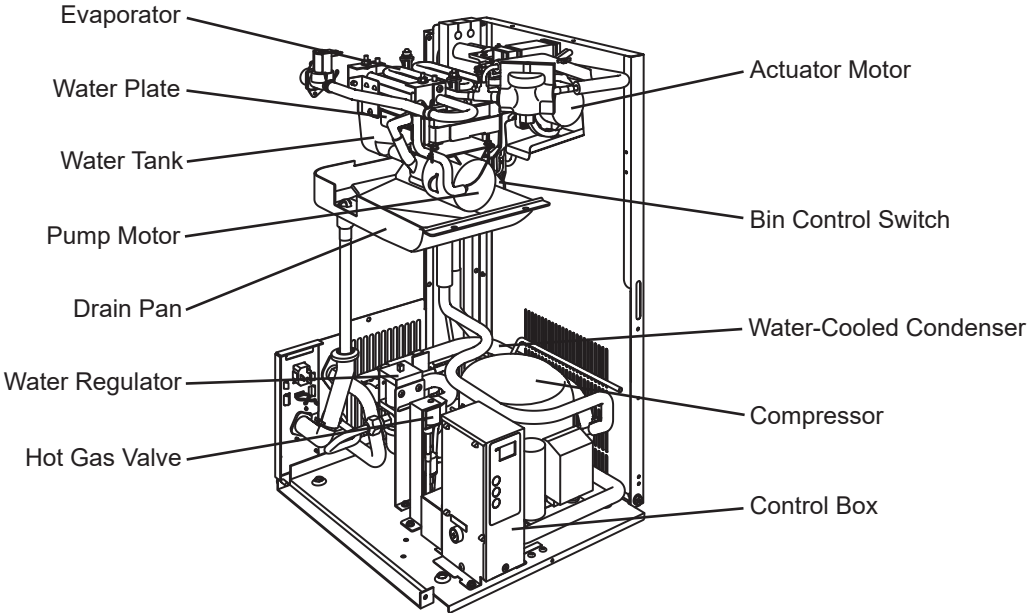
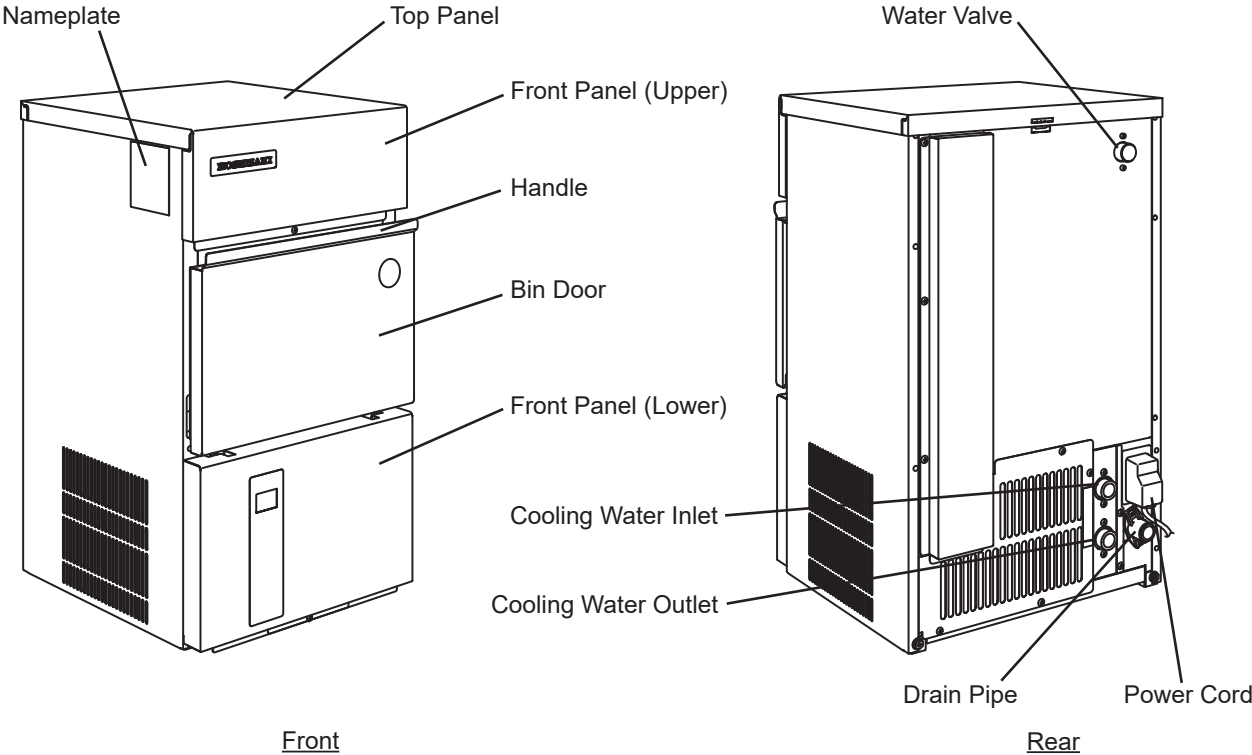

[c] IM-45CNE (Air-cooled)

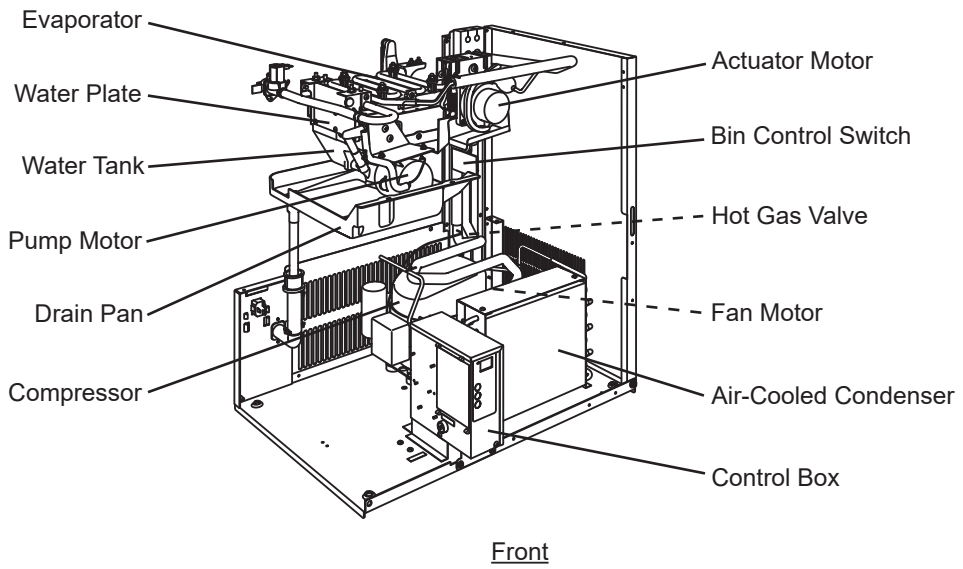
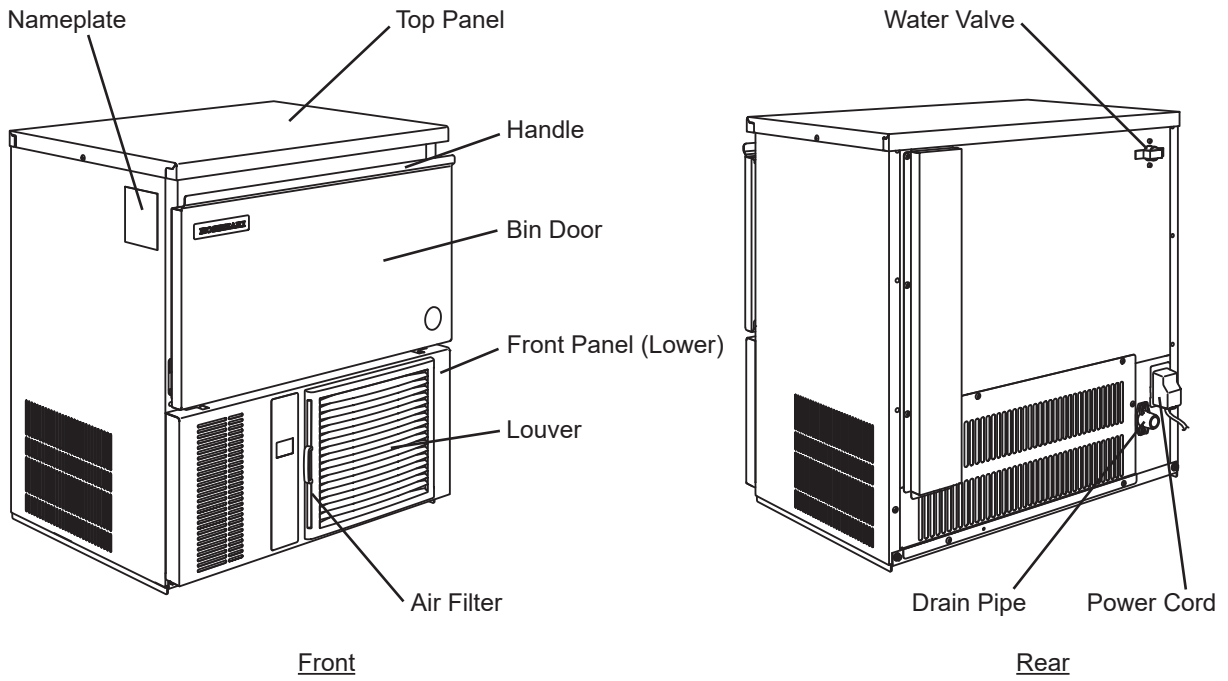

[d] IM-45NE, IM-65NE (Air-cooled)

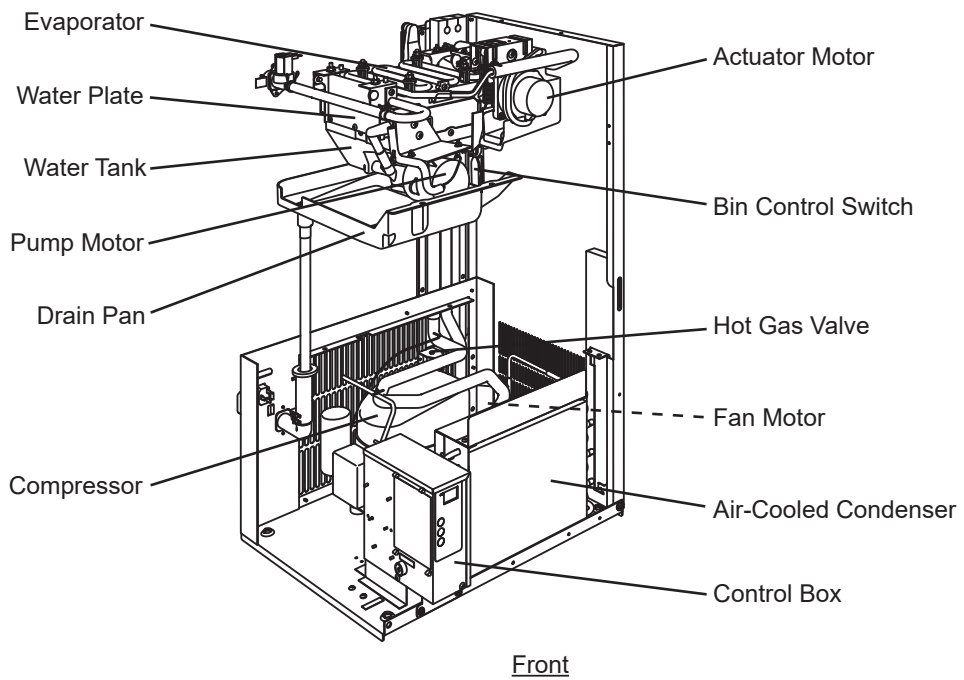
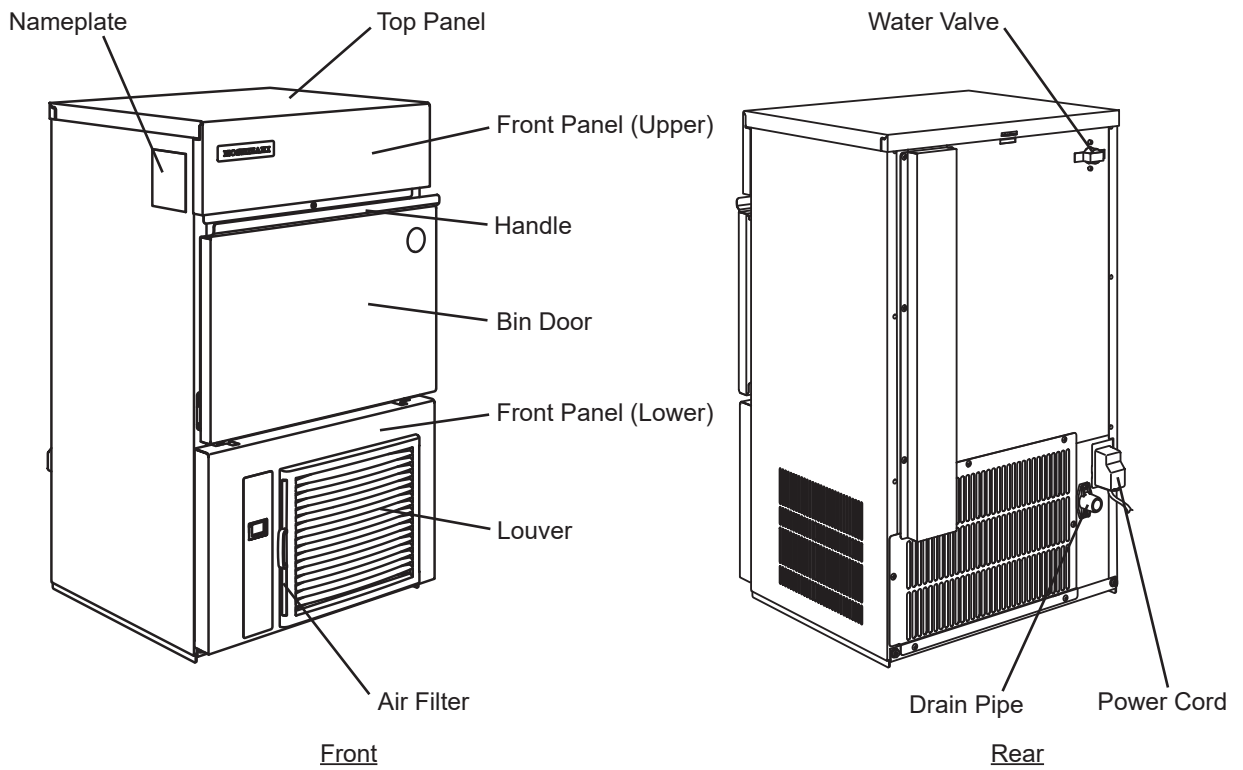

[e] IM-45WNE, IM-65WNE (Water-cooled)

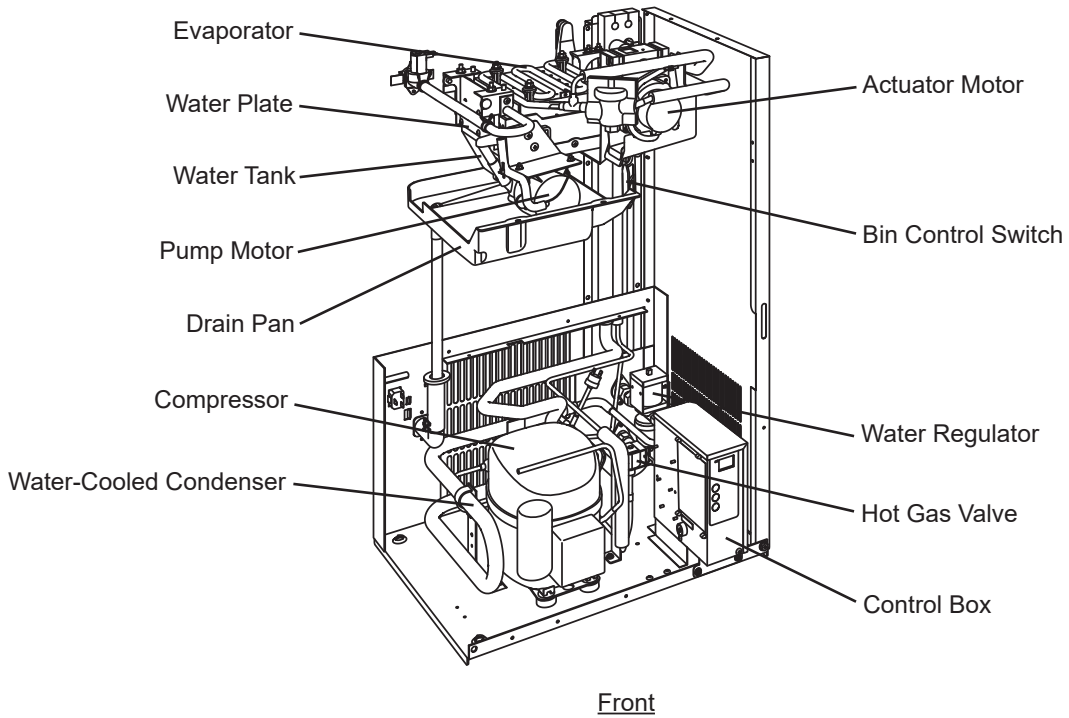
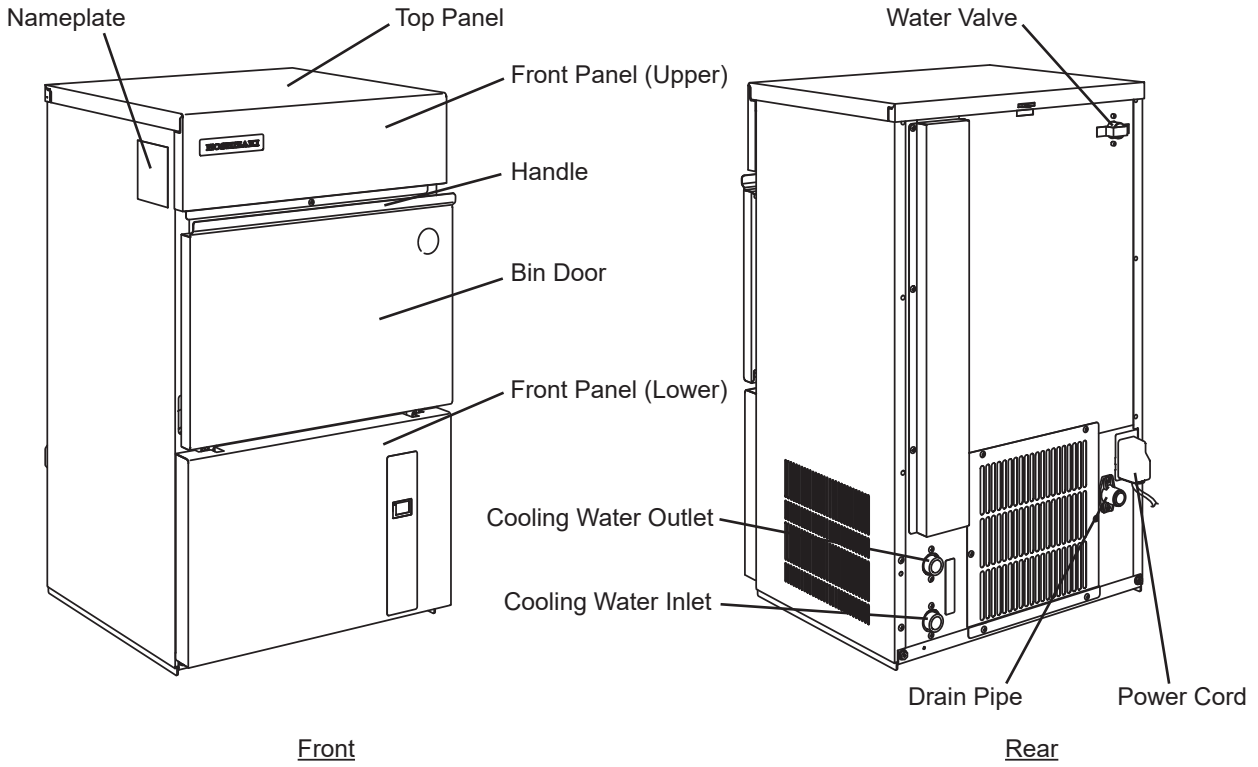

[f] IM-100CNE (Air-cooled)

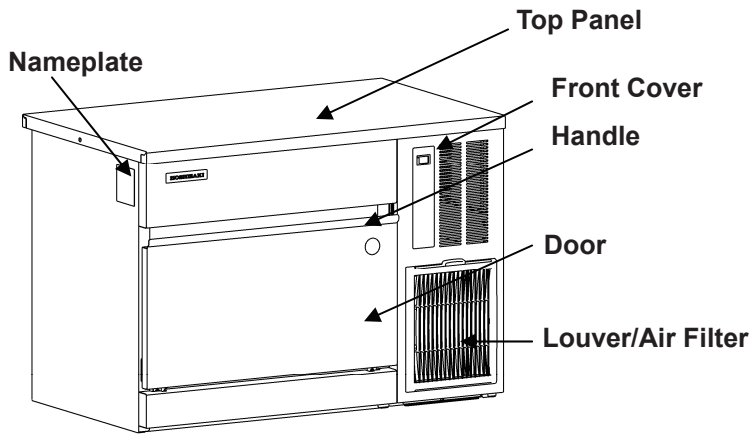

Front

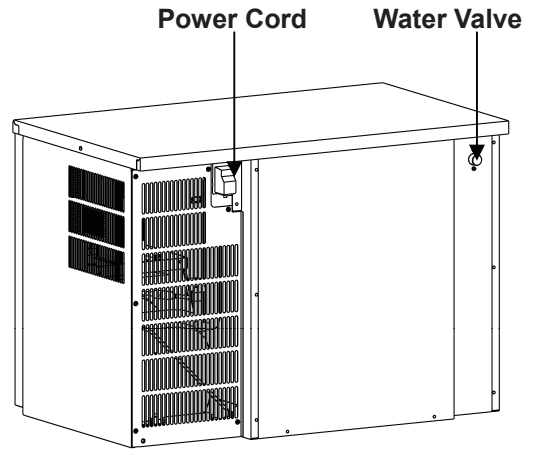

Rear

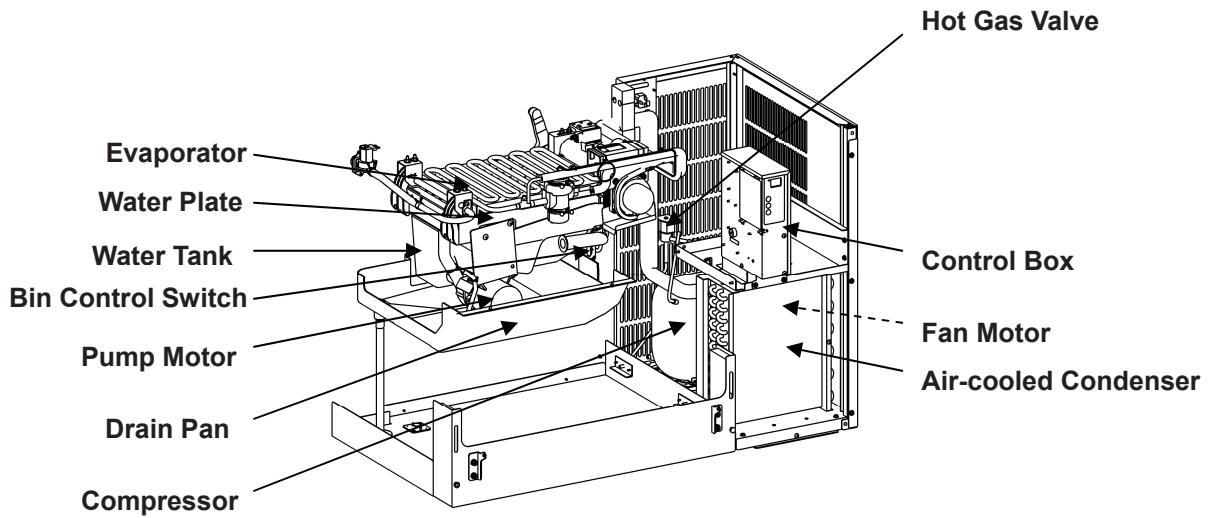

Front

[g] IM-100NE, IM-130NE (Air-cooled)

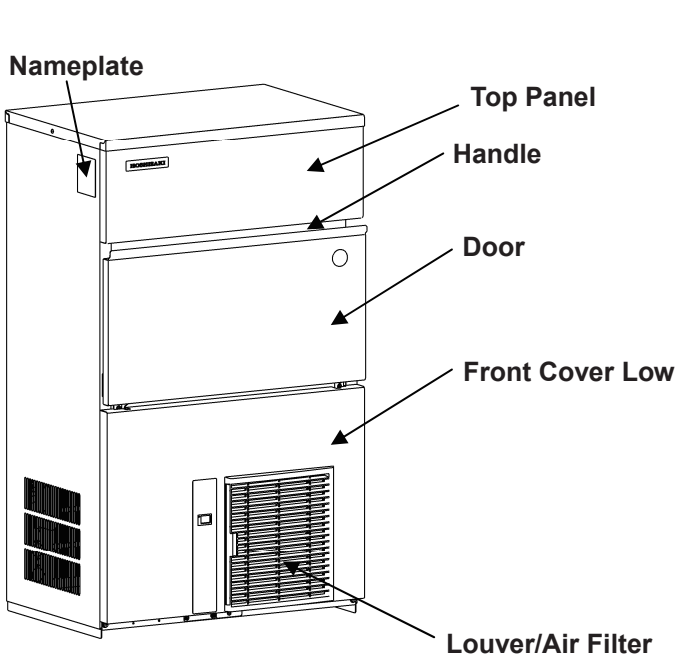

Front

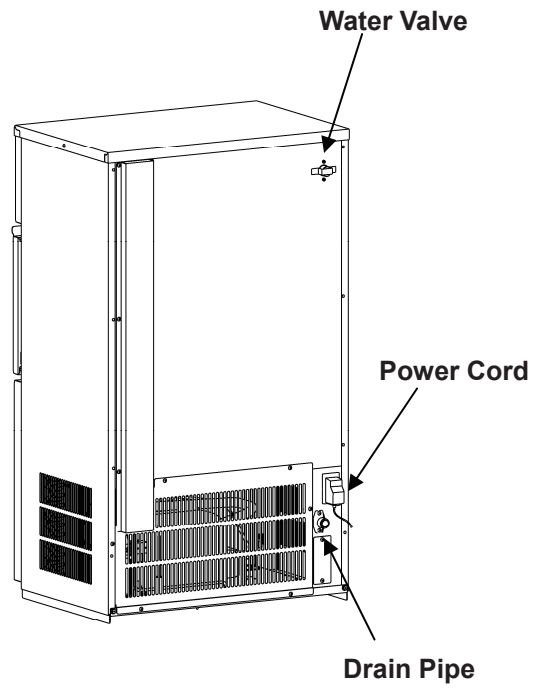

Rear

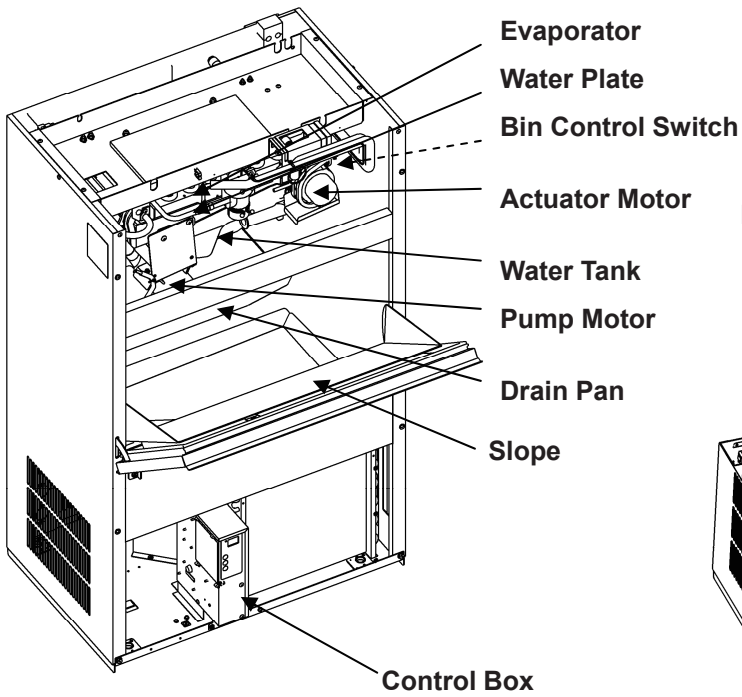

Front

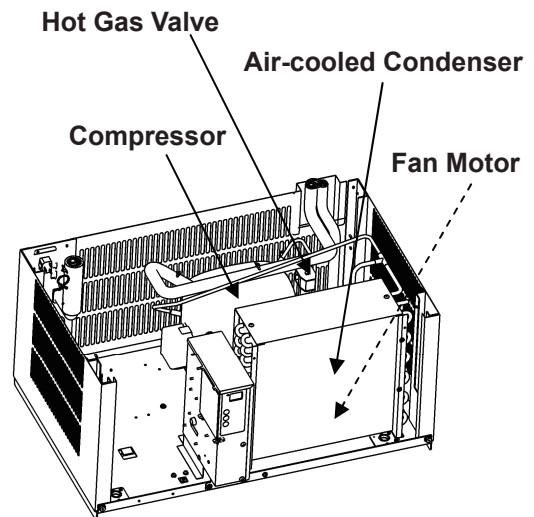

Front

[h] IM-100WNE, IM-130WNE (Water-cooled)

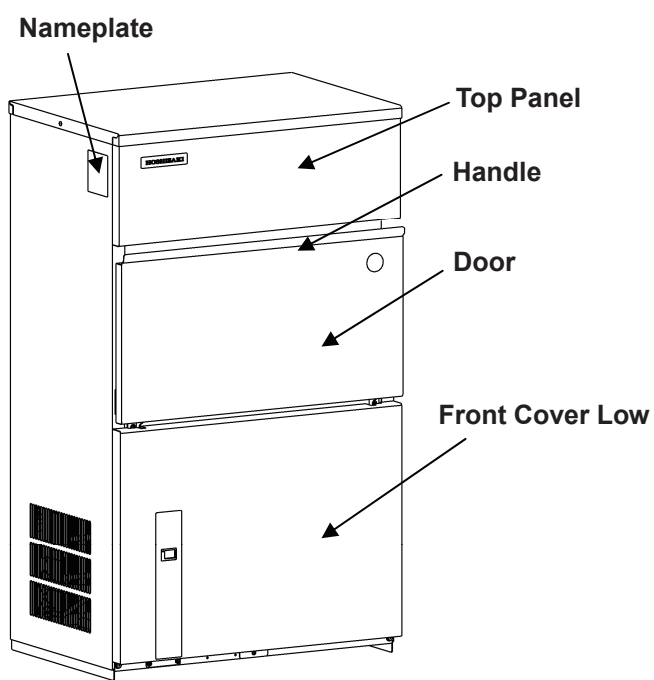

Front

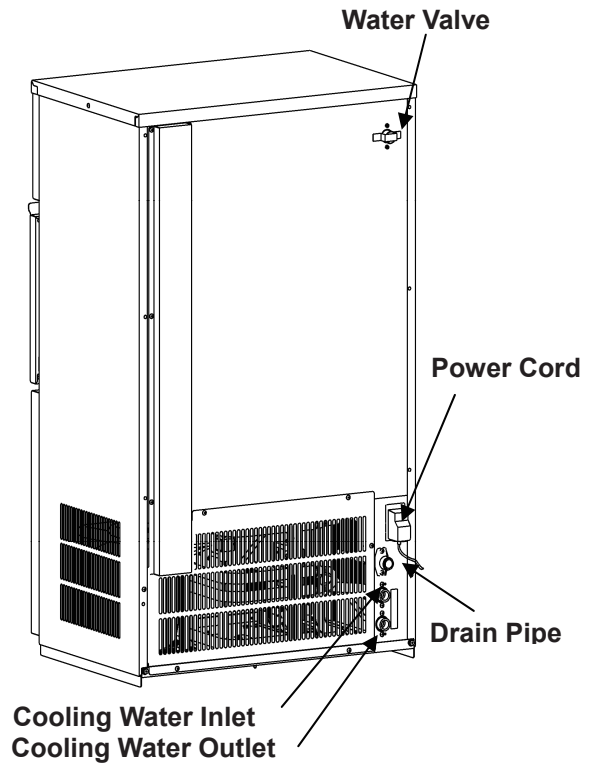

Rear

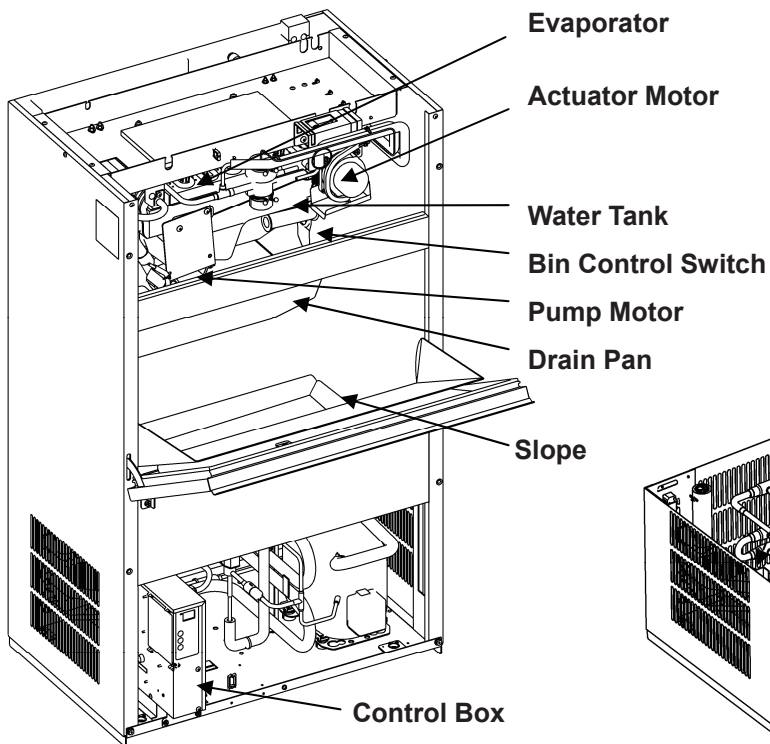

Front

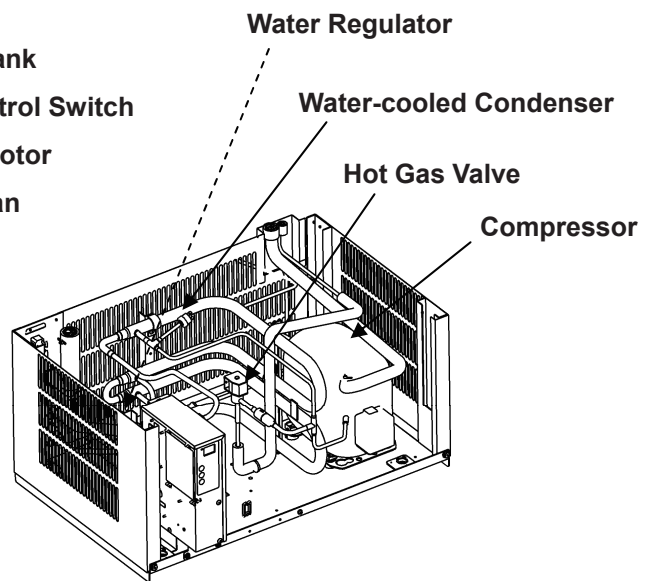

Front

[i] IM-240NE (Air-cooled)

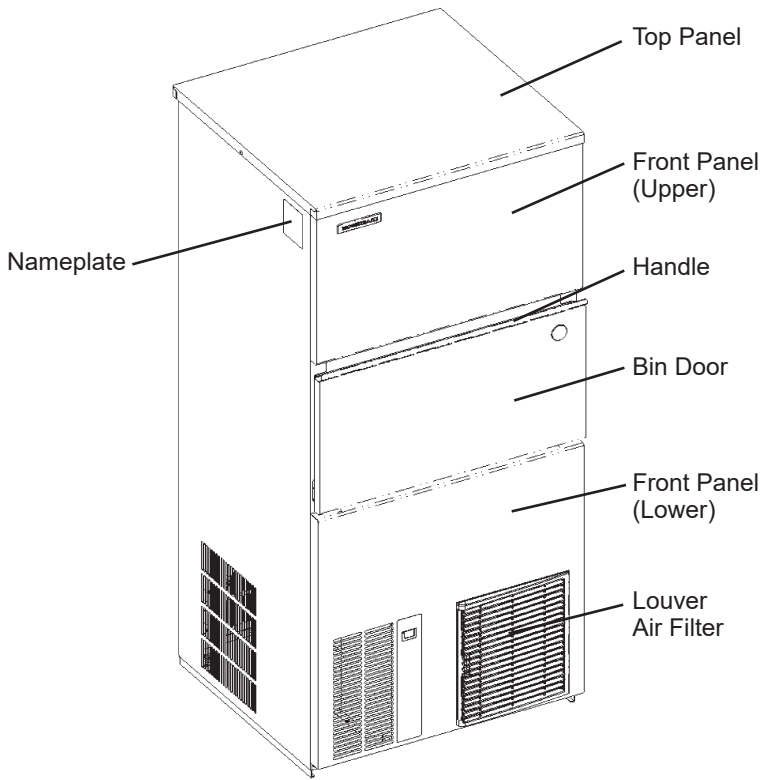

Front

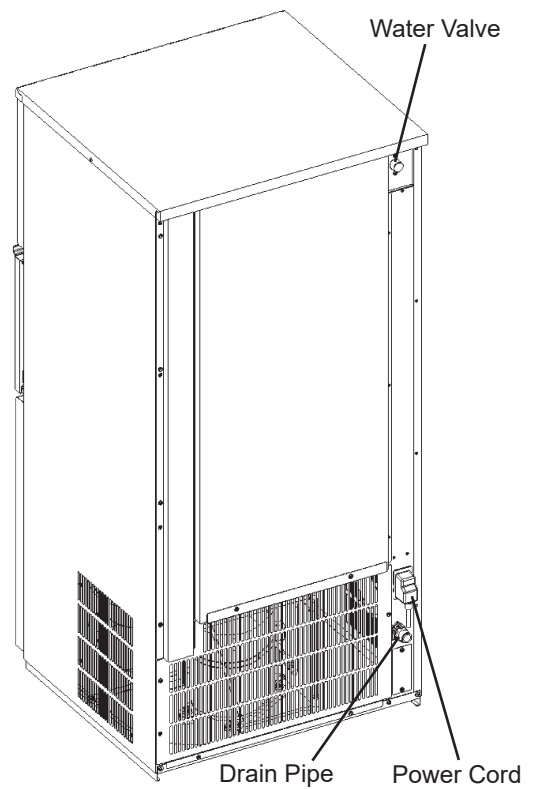

Rear

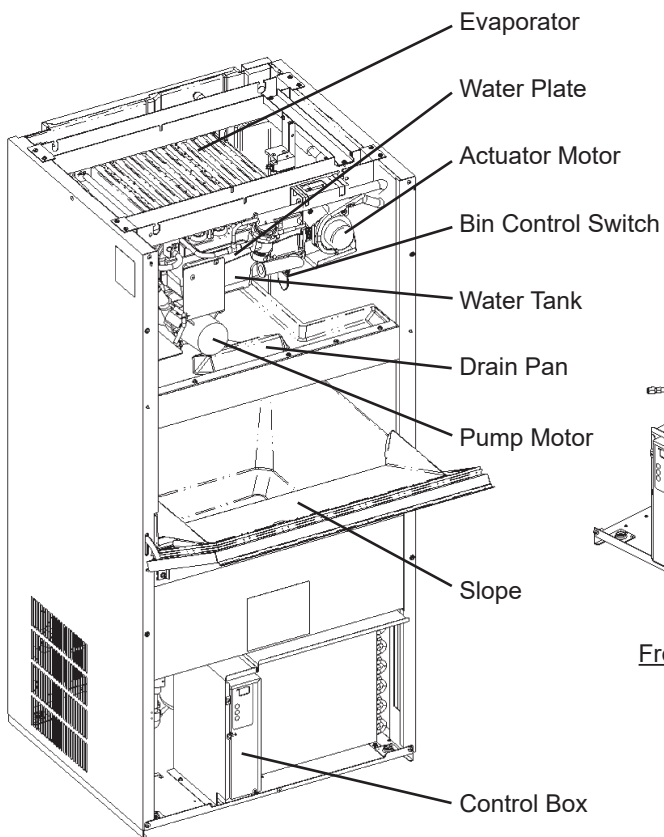

Front

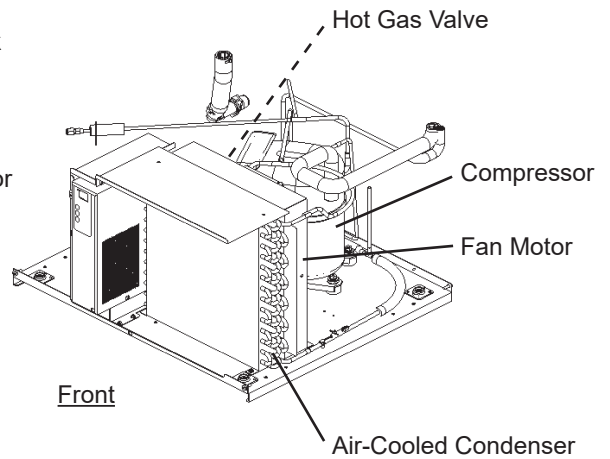

Front

[J] IM-240WNE (Water-cooled)

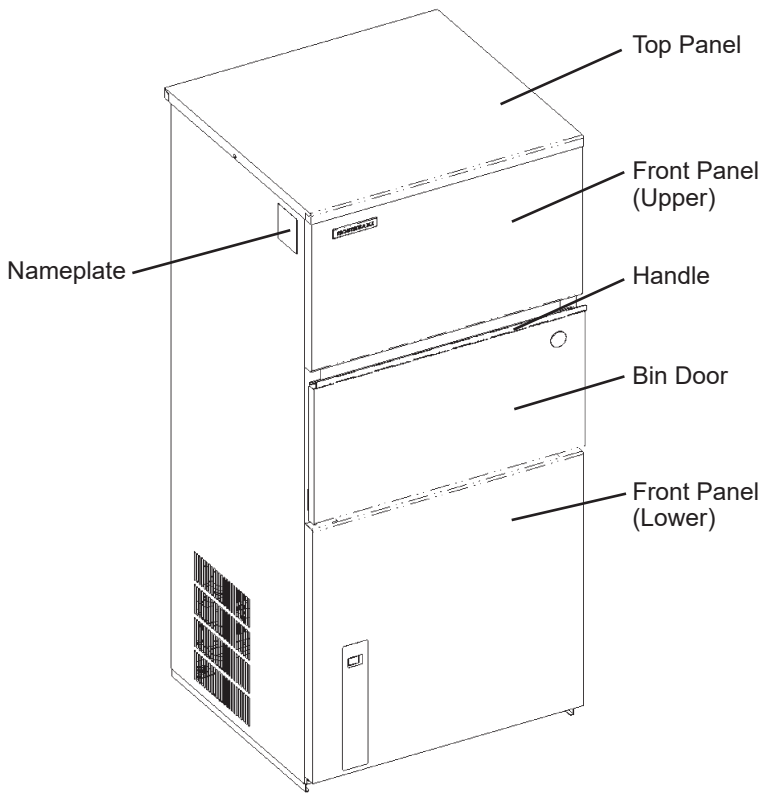

Front

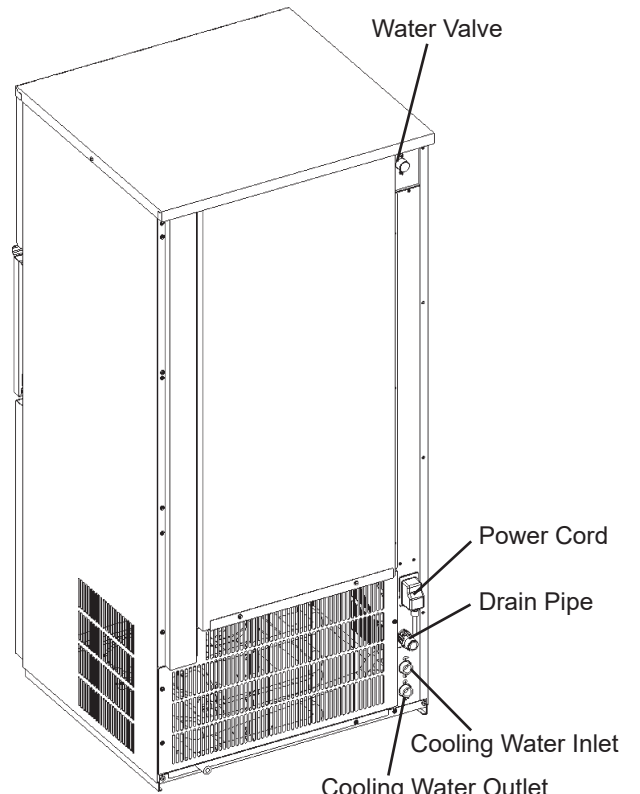

Rear

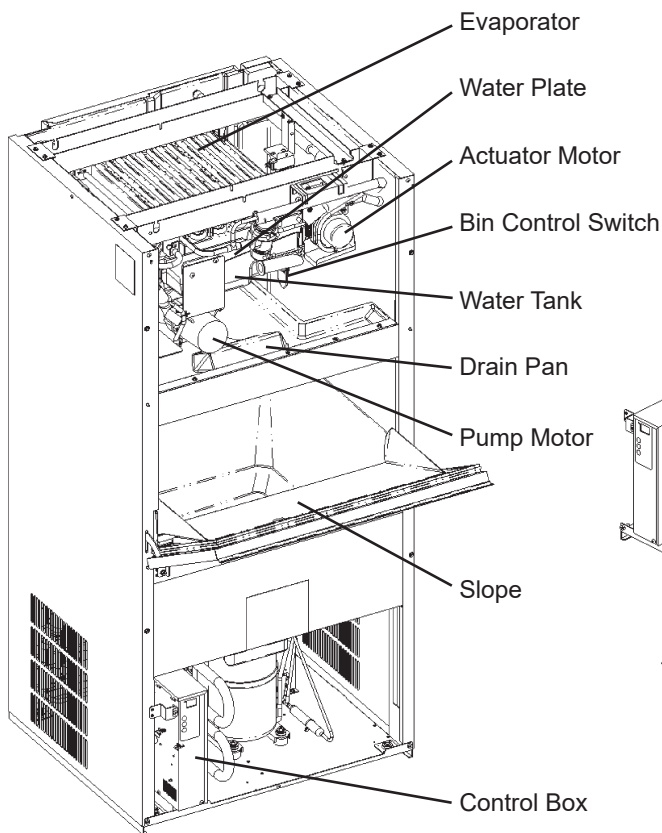

Front

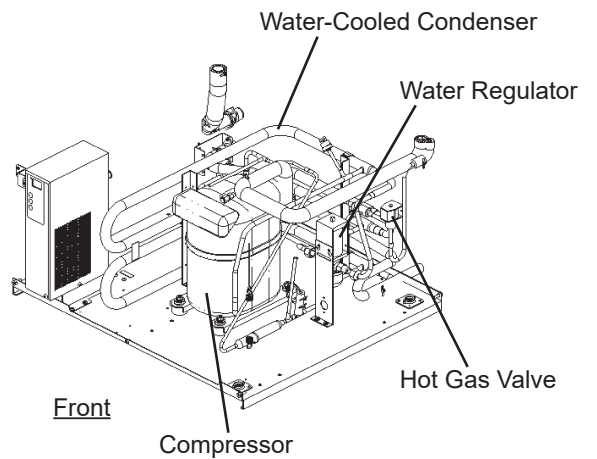

Front

2. CONTROLLER BOARD

Note: Refer to the controller board service manual.

IMPORTANT

If receiving a service call, ask the user to turn off the power to the icemaker and turn it on again, while watching the icemaker. This will reset the controller, and in some cases normal operation will resume.

NOTICE

1. Check that the icemaker has been earthed properly. If not, the controller board will not work properly.
2. Do not change wiring and connections, or the controller board will not work properly.
3. Do not touch the reverse side of the controller board and tiny electronic devices on it.
4. Do not repair the electronic devices and parts on the controller board in the field (except for fuse replacement). Replace the whole board assembly when it fails.
5. To get static free, always touch the metal part of the icemaker before servicing. Electrostatic discharge will cause severe damage to the controller board.
6. The signal ground wire must be connected to the control box when replacing the controller board after service.
7. The controller board is fragile. Handle with care.
 - * Do not drop the board on the floor.
 - * Handle the board by the edges only. Do not touch the electric parts and devices.

[b] INPUT/OUTPUT LAYOUT

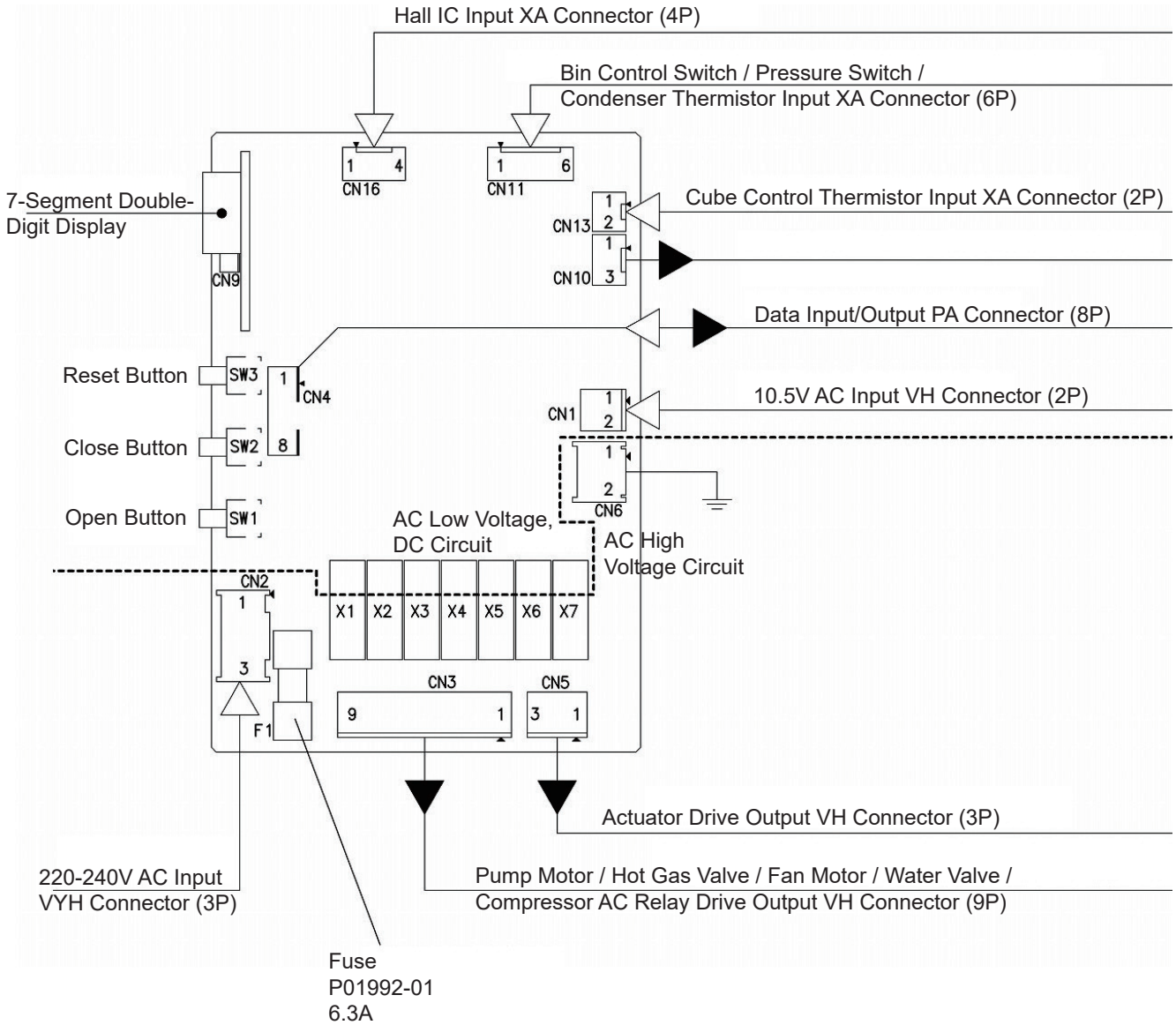

[c] BEFORE CHECKING CONTROLLER BOARD

Check the power source voltage and the components as shown in the table below.

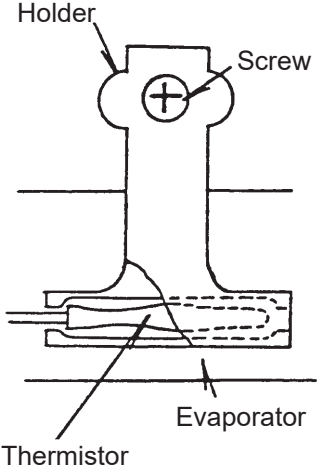
Component	Procedure	Normal
<p>1. Thermistor (on evaporator)</p> 	<div style="border: 1px solid black; padding: 5px; margin-bottom: 10px;"> <p style="text-align: center;">NOTICE</p> <p>Thermistor sensor part is fragile, glass sealed. Handle with care.</p> </div> <ul style="list-style-type: none"> * Disconnect the connector CN13 on the board. * Remove the screw and the thermistor holder on the evaporator. * Immerse the sensor part in a glass containing ice and water for 5 minutes. * Check the resistance between CN13 connector pins. * Replace the thermistor in its correct position. * Connect CN13. 	<p>5 -7 kilohms</p>
<p>2. Bin Control Switch</p>	<p>Manually set the micro switch in the TRIP and RESET positions, and check the period.</p>	<p>Approx. TRIP(Closed) 10 sec. RESET(Open) 80 sec.</p>

III. OPERATING INSTRUCTIONS

WARNING

The use of any electrical equipment involves the observance of some fundamental rules. In particular:

- * Instances of high humidity and moisture increase the risk of electrical short circuits and potential electrical shocks. If in doubt, disconnect the icemaker.
- * Do not damage the power cord or pull it in order to disconnect the icemaker from the electrical supply network.
- * Do not touch the electrical parts or operate the switches with damp hands.
- * This appliance is not intended for use by persons (including children) with reduced physical, sensory or mental capabilities, or lack of experience and knowledge, unless they have been given supervision or instruction concerning use of the appliance by a person responsible for their safety.
- * Young children should be supervised to ensure that they do not play with the appliance.
- * Do not attempt to modify the icemaker. Only qualified personnel may disassemble or repair the appliance.

CAUTION

Do not put your hands into the back of the storage bin or the ice chute on top of the storage bin. Ice may drop off the icemaker, a hard block of ice may suddenly break down, or the icemaking mechanism may suddenly move, resulting in injury.

NOTICE

1. All parts are factory-adjusted. Improper adjustments may result in failure.
2. If the unit is turned off, wait for at least 3 minutes before restarting the icemaker to prevent damage to the compressor.

HYGIENE

This icemaker is designed to produce and store edible ice. To keep the icemaker hygienic:

- * Wash your hands before removing ice. Use the plastic scoop provided (accessory).
- * The storage bin is for ice use only. Do not store anything else in the bin.
- * Clean the storage bin before use (see “IV. 1. PERIODICAL CLEANING”).
- * Keep the scoop clean. Clean it by using a neutral cleaner and rinse thoroughly.

* Close the door after removing ice to prevent entrance of dirt, dust or insects into the storage bin.

1. START UP

- 1) Disconnect the power supply.
- 2) Open the water tap.
- 3) Connect the power supply and energise.
- 4) The following should occur in sequence:
 - a) Hot gas valve will open.
 - b) Compressor will start.
 - c) Water pan will fully open.
 - d) Water valve will open.
 - e) Water pan will start to close (hot gas valve closed).
 - f) Water pan fully closed - pump motor will start.
 - g) Water valve will close.

2. PREPARING THE ICEMAKER FOR LONG STORAGE

⚠ WARNING

Drain the icemaker to prevent damage to the water supply line at subfreezing temperatures, using air or carbon dioxide. Shut off the icemaker until proper air temperature is resumed.

[a] IM-21, 30, 45, 65

- 1) Close the water supply tap, and remove the inlet hose.
- 2) Remove the front panel.
- 3) Push the reset switch. The water pan will start to open.
- 4) Blow out the water supply line immediately after the water pan has opened.

Note: This procedure is necessary to protect the icemaker from freezing up at subfreezing temperature.

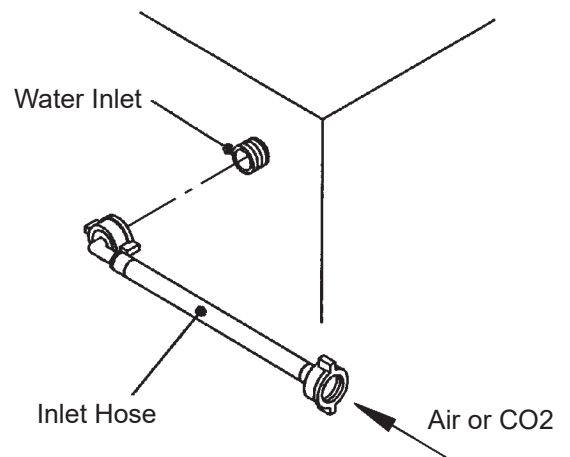

Fig. 1

- 5) Unplug the icemaker or disconnect the power source when the water pan has fully opened.
- 6) Remove all ice from the storage bin, and clean the bin.
- 7) Replace the front panel in its correct position.
- 8) Replace the inlet hose in its correct position.

[b] IM-100, 130, 240

- 1) Close the water supply tap, and remove the inlet hose.
- 2) Remove the front panel.
- 3) Remove the screw located on the front of the water tank.
- 4) Move the tank drain pipe to the drain position. See Fig. 2.
- 5) Push the reset switch. The water pan will start to open.
- 6) Blow out the water supply line immediately after the water pan has opened.

Note: This procedure is necessary to protect the icemaker from freezing up at subfreezing temperature.

- 7) Unplug the icemaker or disconnect the power source when the water pan has fully opened.
- 8) Move the tank drain pipe to the normal position, and secure it with the screw.
- 9) Remove all ice from the storage bin, and clean the bin.
- 10) Replace the front panel in its correct position.
- 11) Replace the inlet hose in its correct position.

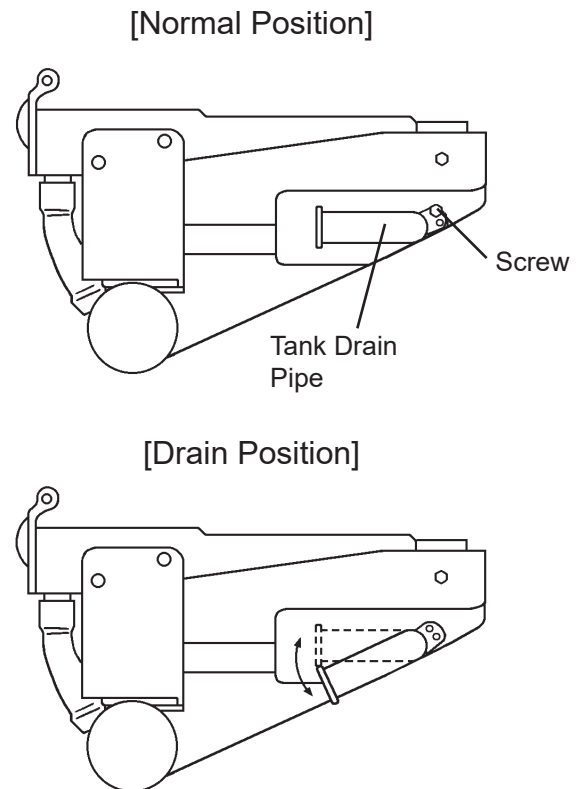

Fig. 2

3. BIN CONTROL

Bin control switch is mounted on the upper side of the storage bin. This switch will turn off the unit automatically when the storage bin is full of ice.

Handle the bin control switch carefully, because the switch assembly is fragile. Especially on removing ice, do not touch or poke with a scoop.

Keep away from the water plate or drain pan to prevent jamming.

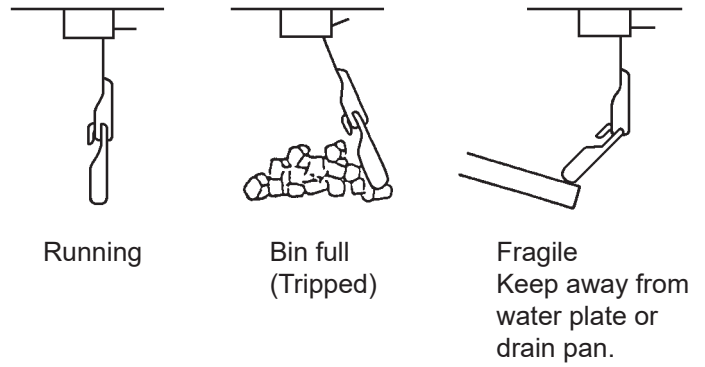

Fig. 3

[a] BIN CONTROL SWITCH ASSEMBLY

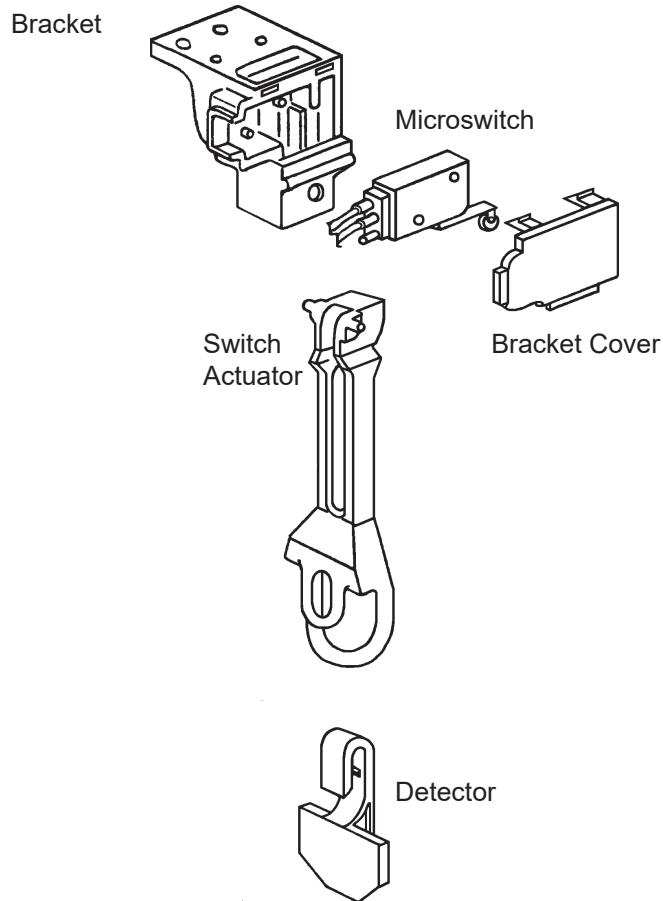

Fig. 4

[b] REMOVAL

BRACKET COVER

Push the two pawls and remove the bracket cover.

SWITCH

Pull out the switch, holding the rubber leads cap. Handle with care.

SWITCH ACTUATOR

Insert a flat blade screwdriver and wrench it slightly to pull out the switch actuator. Handle with care to prevent damage to the cam surface of the actuator.

DETECTOR

Push out the detector, holding the switch actuator.

[c] REASSEMBLING

SWITCH ACTUATOR

Insert the lower shaft and push it along the U notch. Check that the switch actuator moves free.

SWITCH & BRACKET COVER

Place the switch lever first, and then attach the switch in position. Insert the guide and push the bracket cover to lock.

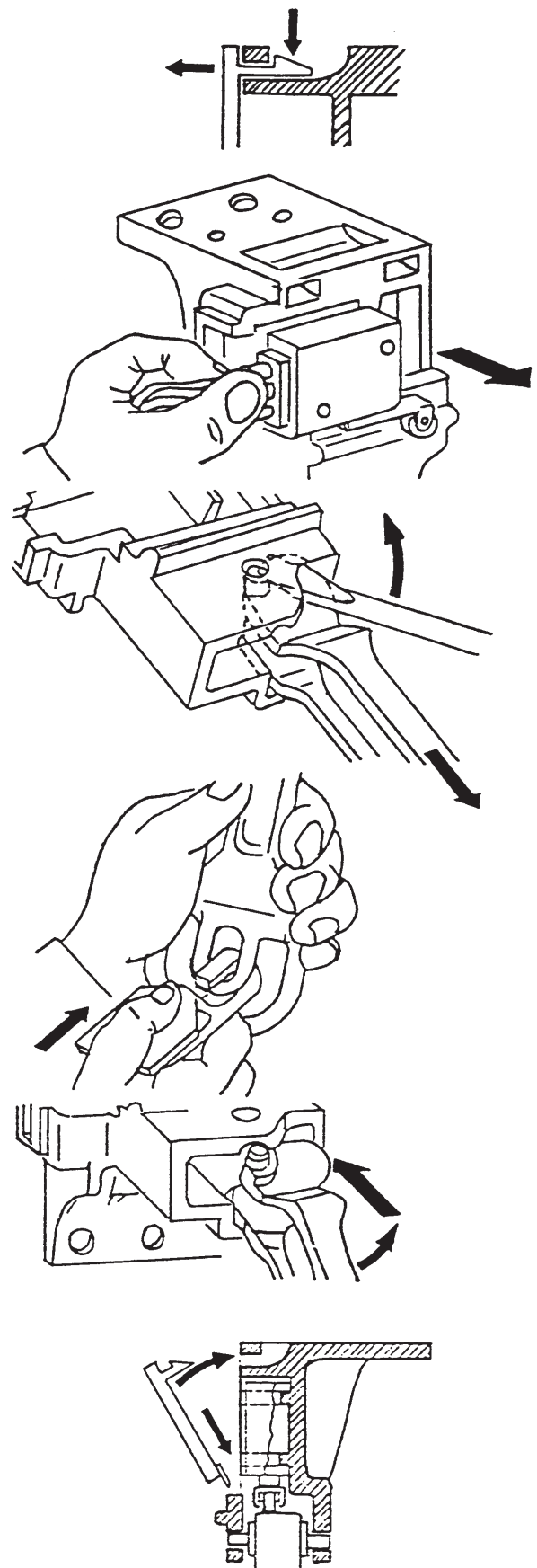

Fig. 5

IV. MAINTENANCE INSTRUCTIONS

WARNING

1. Before carrying out any cleaning or maintenance operations, unplug the icemaker from the electrical supply network.
2. This appliance must not be cleaned by use of a water jet.

CAUTION

Before handling or using cleaning solutions, check the guidelines on the product for advice on suitable personal protective clothing, gloves, goggles, etc.

NOTICE

1. Clean and sanitize the icemaker water system at least twice a year, and check and clean the condenser at least once a year.
2. To prevent possible damage, do not clean the plastic parts with water above 40°C or in a dishwasher.

1. PERIODICAL CLEANING

[1] Machine and Bin Exterior

Wipe the exterior at least once per week with a clean, soft cloth. Use a damp cloth containing a neutral cleaner to wipe off grease or dirt.

[2] Scoop and Storage Bin Handle Cleaning/Sanitisation (Daily)

- 1) Either mix 1 litre of water with 4 ml of 5.25% sodium hypochlorite solution in a suitable container, or the recommended Hoshizaki sanitiser as directed.
- 2) Soak the scoop in the solution for more than 3 minutes. Rinse thoroughly, and shake to remove surplus liquid.

Note: Using a cloth to dry may re-contaminate.

- 3) Use a neutral cleaner to wash the storage bin handle. Rinse thoroughly.
- 4) Soak a clean cloth with the sanitising solution, and wipe the handle. Use fresh water and a clean cloth to rinse/dry.

[3] Storage Bin Interior Cleaning/Sanitisation (Weekly)

- 1) Open the storage bin door, and remove all ice.
- 2) Wash the bin liner with a neutral non-abrasive cleaner. Rinse thoroughly.
- 3) Soak a clean cloth with the neutral cleaner, and wipe both sides of the slope and the door inner surface. Wipe off the cleaner with a clean damp cloth.
- 4) Either mix 5 litres of water with 18 ml of 5.25% sodium hypochlorite solution in a suitable container, or the recommended Hoshizaki sanitiser as directed.
- 5) Soak a clean sponge or cloth with the solution, and wipe the bin liner, bin door and slope.
- 6) The remaining solution can be used to sanitise utensils.

Note: Do not wipe dry or rinse after sanitising, but allow to air dry.

[4] Air Filter (Air-Cooled Model Only)

Plastic mesh air filters remove dirt or dust from the air, and keep the condenser from getting clogged. If the filters get clogged, the icemaker's performance will be reduced. Remove and clean the air filters at least twice per month:

- 1) Slide the air filter off the filter guide [IM-21CNE/30CNE] or the louver [IM-45CNE/45NE/65NE/100CNE/100NE/130NE/240NE].

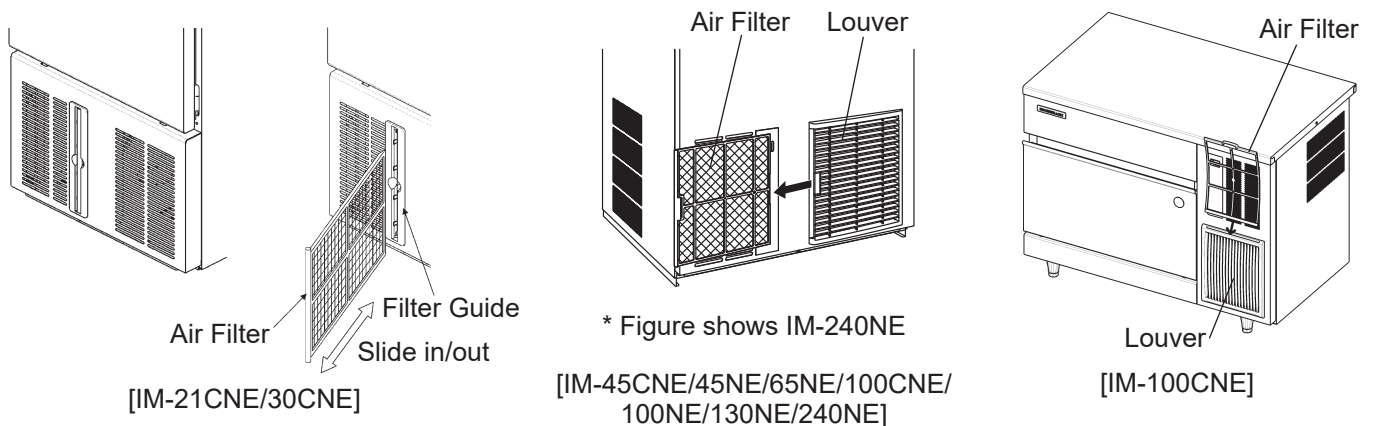

Fig. 6

- 2) Clean the air filter by using a vacuum cleaner. When severely clogged, use warm water and a neutral cleaner to wash the air filter.
- 3) Rinse and dry the air filter thoroughly.

NOTICE

After cleaning, be sure to place the air filter back in position.

2. WATER VALVE

- 1) Unplug the icemaker or disconnect the power source.
- 2) Close the water supply tap.
- 3) Remove the top panel and front panel.
- 4) Disconnect the inlet hose from the water valve.
- 5) Remove the mesh filter from the water valve.
- 6) Clean the mesh using a brush.
- 7) Replace the mesh and inlet hose in their correct positions.
- 8) Open the shut-off valve.
- 9) Plug in the icemaker or connect the power source.
- 10) Check for leaks.
- 11) Replace the panels in their correct positions.

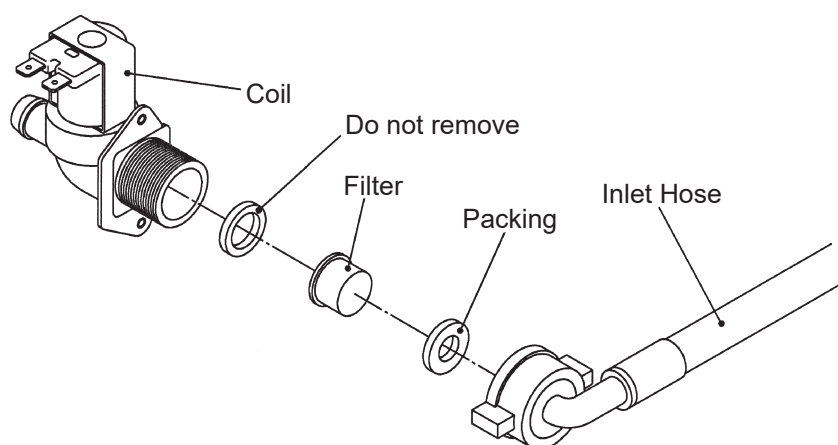

Fig. 7

3. WATER-COOLED CONDENSER

Deposits inside the water circuit of the water-cooled condenser decrease cooling performance. Clean inside of the condenser by circulating a cleaning solution.

1) Prepare the following:

Cleaning solution [Read and follow any instructions on label or bottle.]

Pump Container for solution Hose Hose bands

Two fittings [R1/2 - 3/8" DIA] Two fittings [3/8" flare - 3/8" DIA]

NOTICE

Do not use a cleaning solution that will corrode the copper tubing. In case of contact with the solution, flush with water.

- 2) Remove the panels and check for leaks from the water line.
- 3) Unplug the icemaker or disconnect the power source, and close the water supply tap.
- 4) Disconnect the cooling water inlet and outlet pipings and attach fittings to connect hoses.
- 5) Disconnect the inlet and outlet tubings of the water regulator and replace the water regulator by fittings.
- 6) Connect hoses as shown in Fig. 8 and secure them by hose bands.

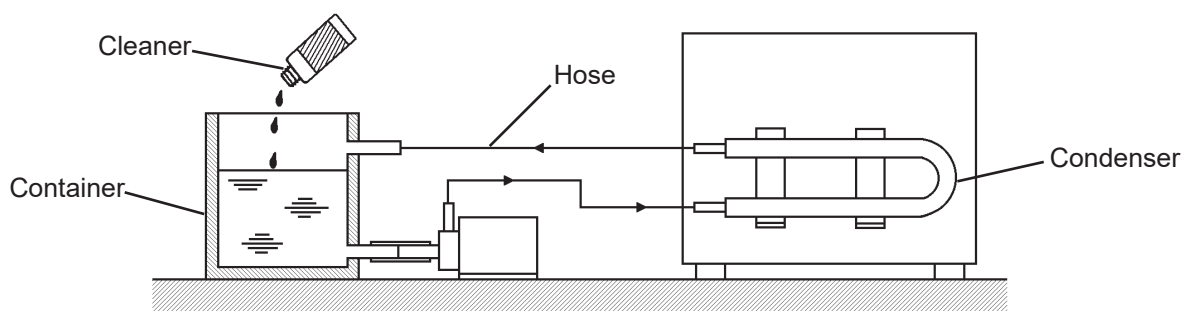

Fig. 8

- 7) Fill the container with the cleaning solution.
- 8) Run the pump motor and circulate the solution for a period recommended in the instructions on label or bottle of the cleaner.
- 9) Rinse the water circuit.

10) Reverse the above procedure in steps 2) through 6).

11) Check the icemaking capacity referring to “V. 3. PERFORMANCE DATA”.

4. ICEMAKING WATER SYSTEM

To keep the icemaker hygienic, clean and sanitize the icemaking water system at least once every six months. More frequent cleaning and sanitizing may be required depending on the water quality.

CAUTION

Always wear rubber gloves, eye protectors, apron, etc. for safe handling of the cleaner and sanitizer.

NOTICE

1. Use the cleaners and sanitizers recommended by Hoshizaki. Contact your local Hoshizaki office for further details. (The instructions below give an example of those recommended cleaners and sanitizers.)
2. Never mix cleaning and sanitizing solutions in an attempt to shorten cleaning time.
3. Wipe off any splashed or spilt cleaner/sanitizer immediately.
4. Do not use any ammonia type cleaners on any part of the icemaker.
5. When the ambient and water temperatures are 10°C or below, the water pan may remain open. Warm the icemaking compartment up to 20°C around the thermistor.
6. Be sure to follow the cleaning and sanitizing instructions below.

- 1) Use a suitable container to dilute 236 ml of the cleaner (“Nickel-Safe Ice Machine Cleaner” by The Rectorseal Corporation) with 11.4 lit. of water.
- 2) Open the storage bin door, and remove all the ice to avoid contaminating by the cleaner.
- 3) Remove the front and top panels.
- 4) If the icemaker is in a defrost cycle, wait until a freeze cycle starts.
- 5) Close the water supply tap.

- 6) [IM-100, 130, 240 only]
Remove the screw, and move the tank drain pipe to the drain position. See Fig. 2.
- 7) Push the reset switch to open the water pan.
- 8) Unplug the icemaker or disconnect the power source when the water pan has fully opened.
- 9) After the water has completely drained out, plug in the icemaker or connect the power source. When the 7-segment display on the controller board turns on, press DOWN on the controller board for 3 seconds to start the flush mode. (See the controller board service manual for further details.)
- 10) When the flush mode has started, pour the cleaning solution prepared in 1) carefully into the water tank within 60 seconds before the pump motor starts. Do not splash or spill the solution onto the other parts.
- 11) Circulate the cleaning solution for 30 minutes. Push the reset switch to open the water pan. Unplug the icemaker or disconnect the power source when the water pan has fully opened. Wait until the cleaning solution has completely drained out.
- 12) Open the water supply tap, and repeat the above step 9). Since the water supply tap is open this time, water is supplied as in the normal freeze cycle.
- 13) When the water pan closes again, pour clean water into the water pan until it floods from the overflow pipe, and circulate the water for 5 minutes.
- 14) Push the reset switch to open the water pan and drain the water. This time the water does not drain out completely.
- 15) Repeat the above steps 13) and 14) at least three times to rinse thoroughly. To drain the rinse water completely, unplug the icemaker or disconnect the power source when the water pan has fully opened.

SANITIZING INSTRUCTIONS

Note: Sanitizing should always be completed after cleaning or alternately as an individual procedure if conditions exist to make it necessary.

- 16) Use a suitable container to dilute 44 ml of 5.25% sodium hypochlorite solution with 11.4 lit. of water.

* Alternatively use the Hoshizaki recommended sanitizer as directed by the relevant instructions.

- 17) Close the water supply tap. Plug in the icemaker or connect the power source. When the 7-segment display on the controller board turns on, press DOWN on the controller board for 3 seconds to start the flush mode.
- 18) When the flush mode has started, pour the cleaning solution prepared in 16) carefully into the water tank within 60 seconds before the pump motor starts. Do not splash or spill the solution onto the other parts.
- 19) Circulate the sanitizing solution for 15 minutes. Push the reset switch to open the water pan. Unplug the icemaker or disconnect the power source when the water pan has fully opened. Wait until the sanitizing solution has completely drained out.
- 20) Open the water supply tap, and repeat the above step 9). Since the water supply tap is open this time, water is supplied as in the normal freeze cycle.
- 21) When the water pan closes again, pour clean water into the water pan until it floods from the overflow pipe, and circulate the water for 5 minutes.
- 22) Push the reset switch to open the water pan and drain the water. This time the water does not drain out completely.
- 23) Repeat the above steps 21) and 22) at least three times to rinse thoroughly. To drain the rinse water completely, unplug the icemaker or disconnect the power source when the water pan has fully opened.
- 24) [IM-100, 130, 240 only]
Move the tank drain pipe to the normal position, and secure it with the screw. See Fig. 2.
- 25) Plug in the icemaker or connect the power source. Check for proper icemaking operation.
- 26) Replace the front panel and top panel in their correct positions.
- 27) Complete storage bin cleaning as detailed in IV. 1. [3].

V. TECHNICAL INFORMATION

1. WATER CIRCUIT AND REFRIGERANT CIRCUIT

[a] IM-21CNE, IM-30CNE, IM-45CNE, IM-45NE, IM-65NE (Air-cooled)

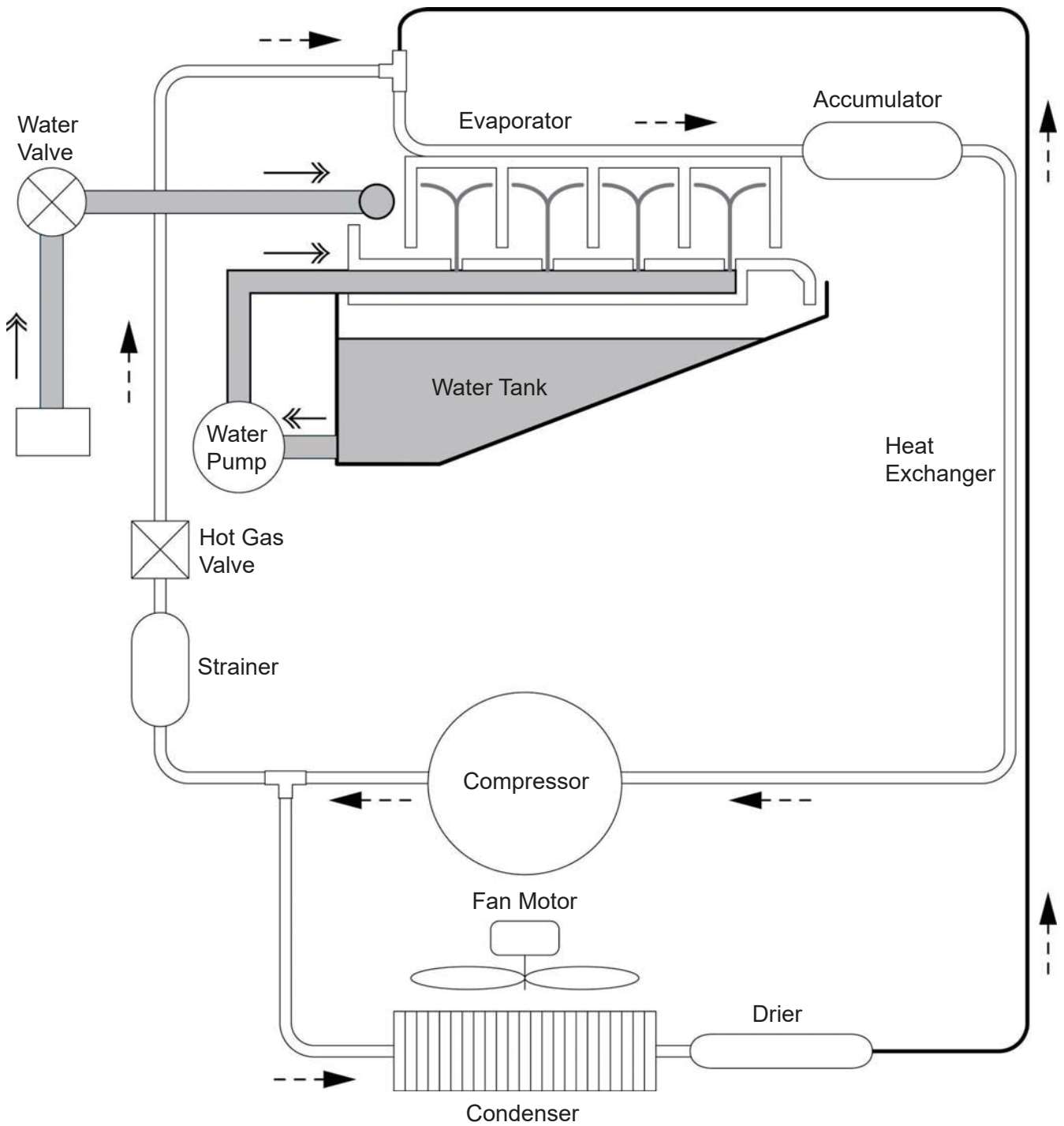

[b] IM-100CNE, IM-100NE, IM-130NE, IM-240NE (Air-cooled)

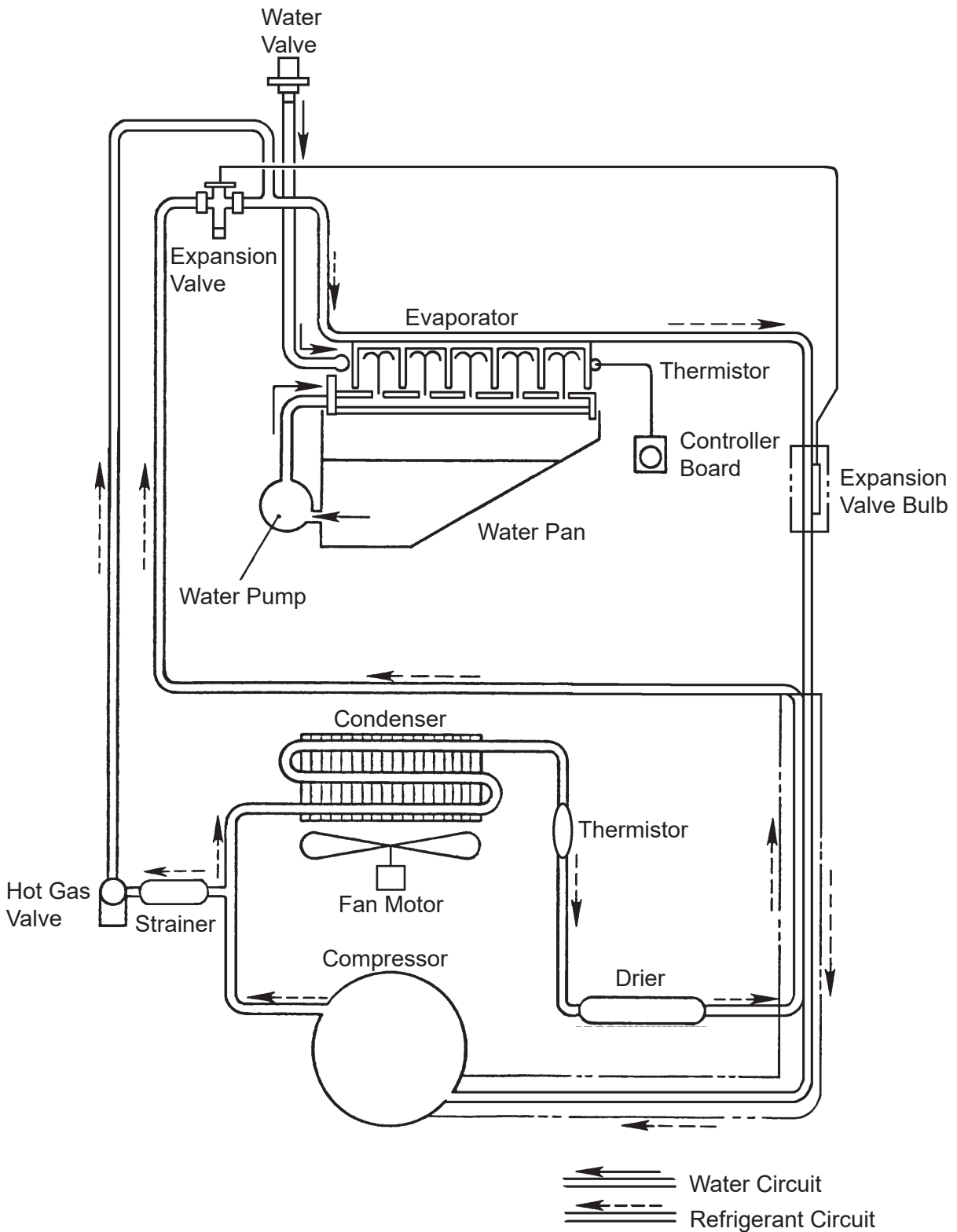

[c] IM-65WNE (Water-cooled)

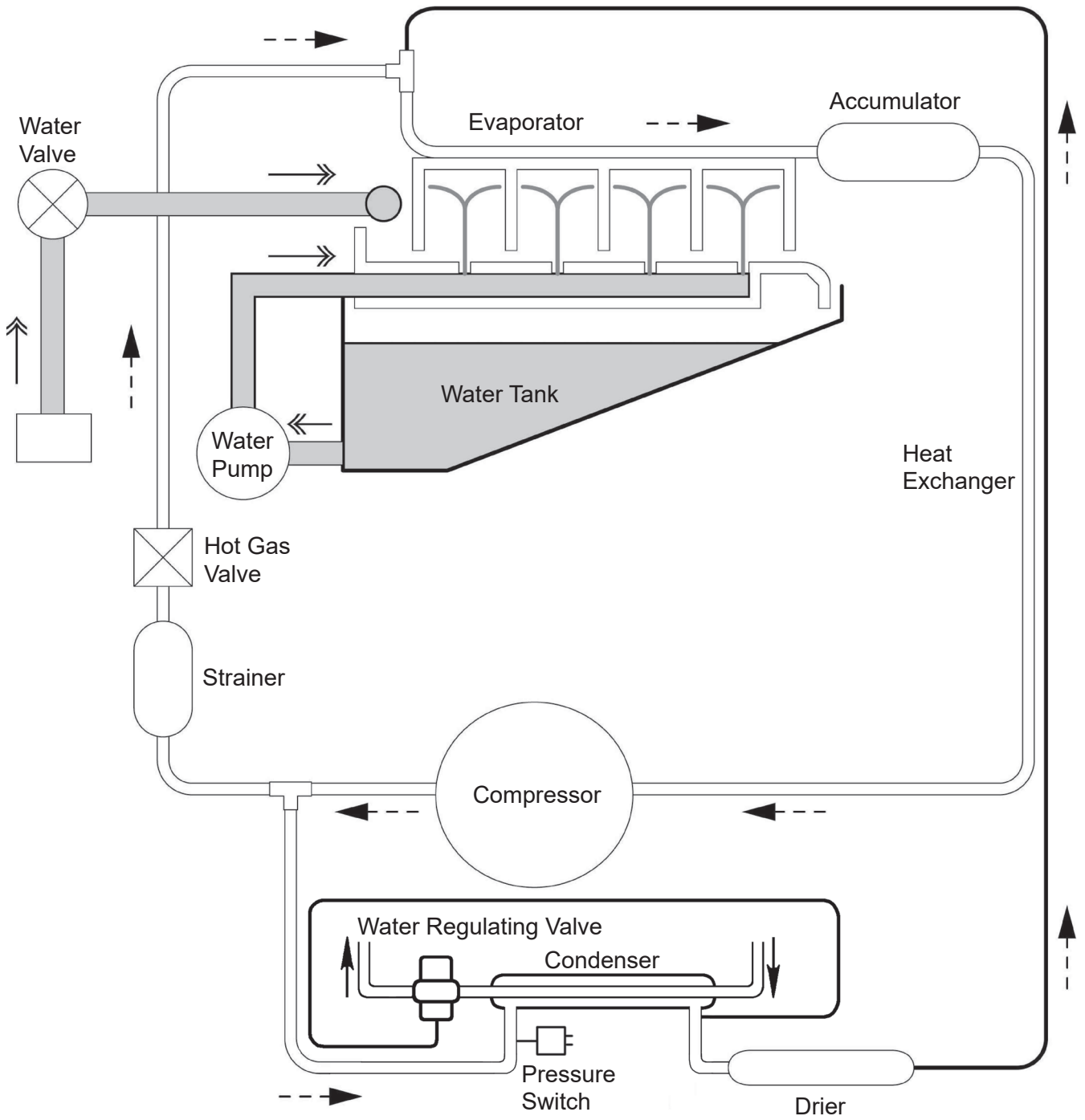

[d] IM-30CWNE, IM-45WNE, IM-100WNE, IM-130WNE, IM-240WNE (Water-cooled)

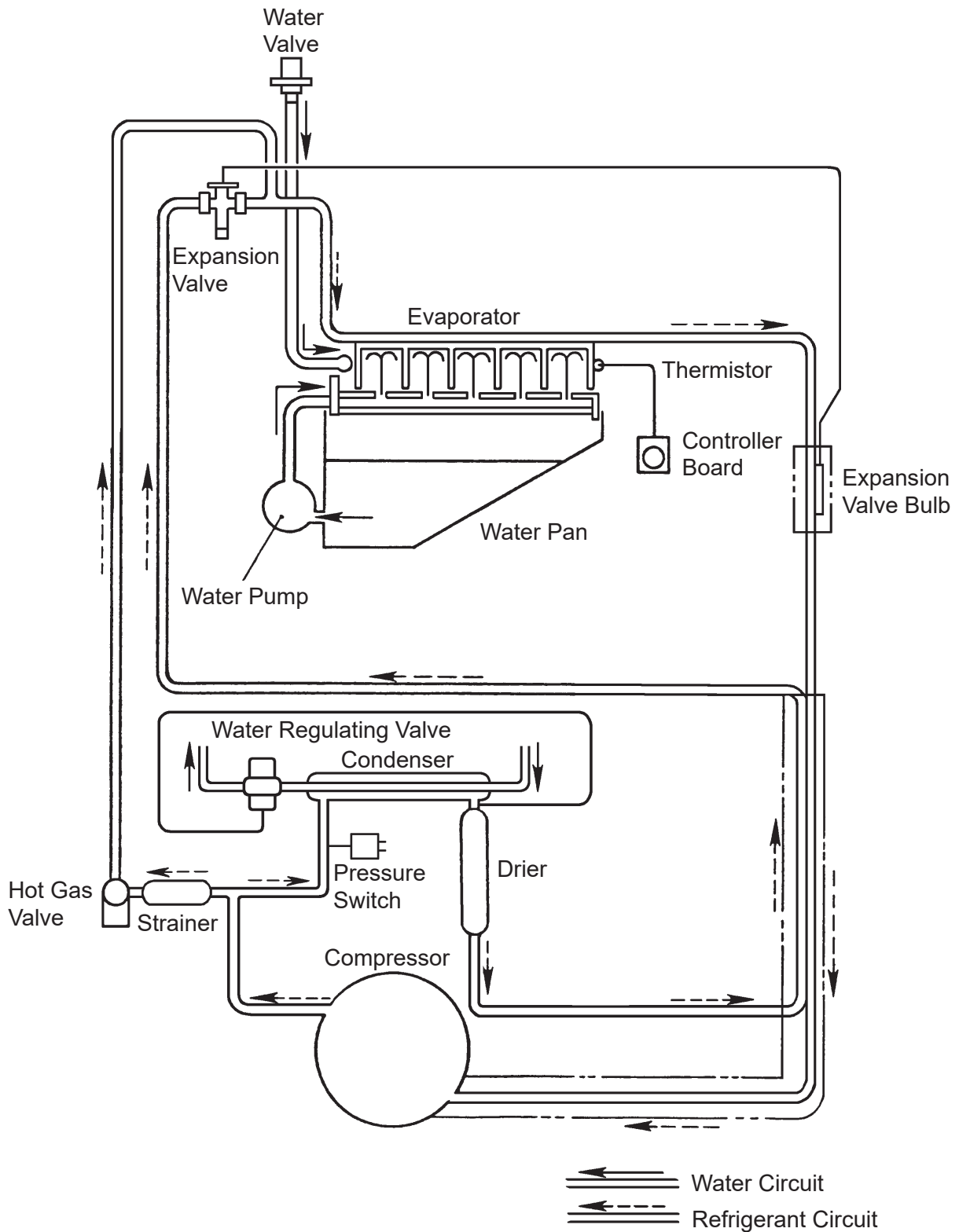

2. WIRING DIAGRAM

[a] IM-21CNE, IM-30CNE, IM-30CWNE

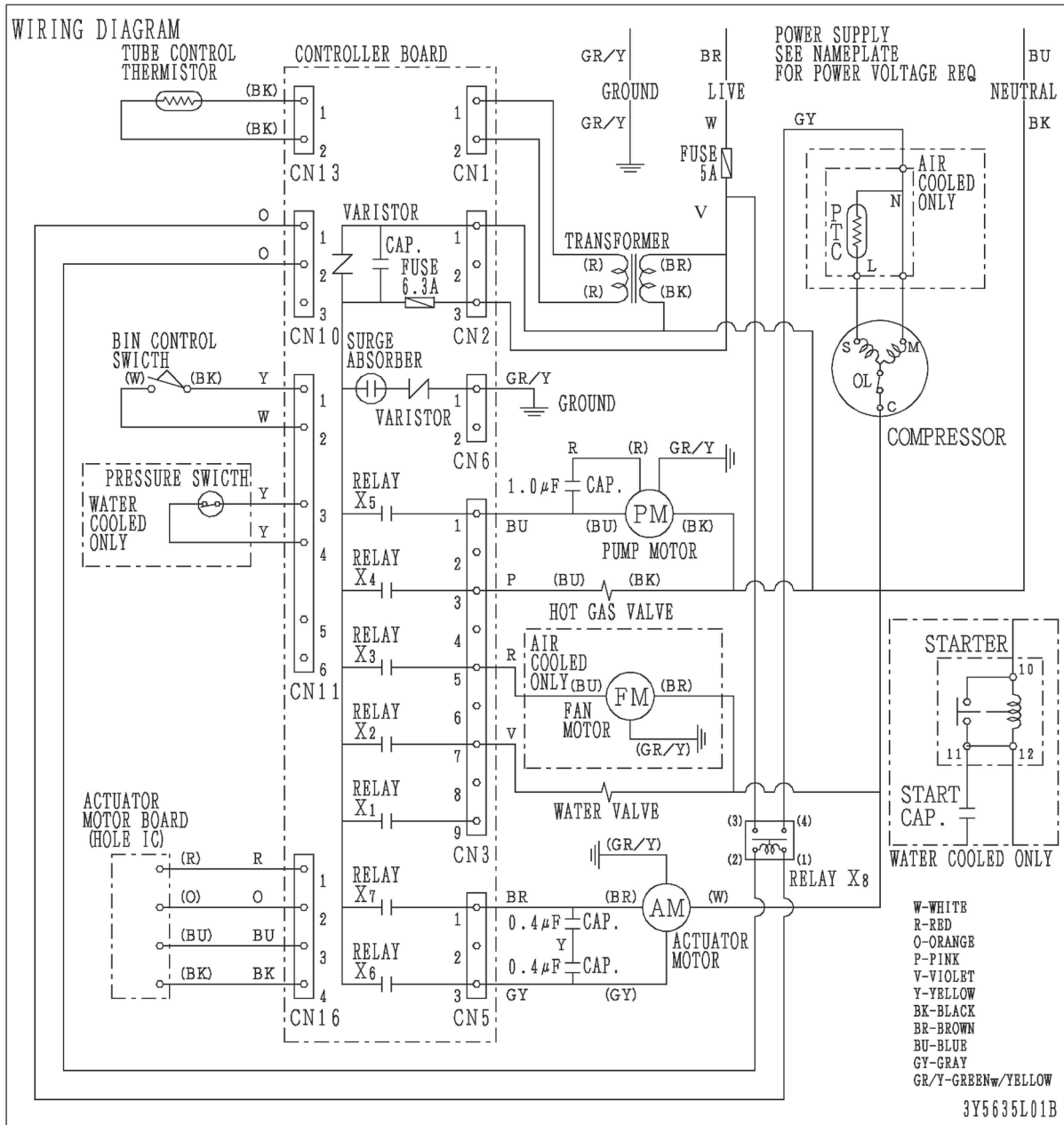

[b] IM-45CNE, IM-45NE, IM-45WNE, IM-65NE, IM-65WNE

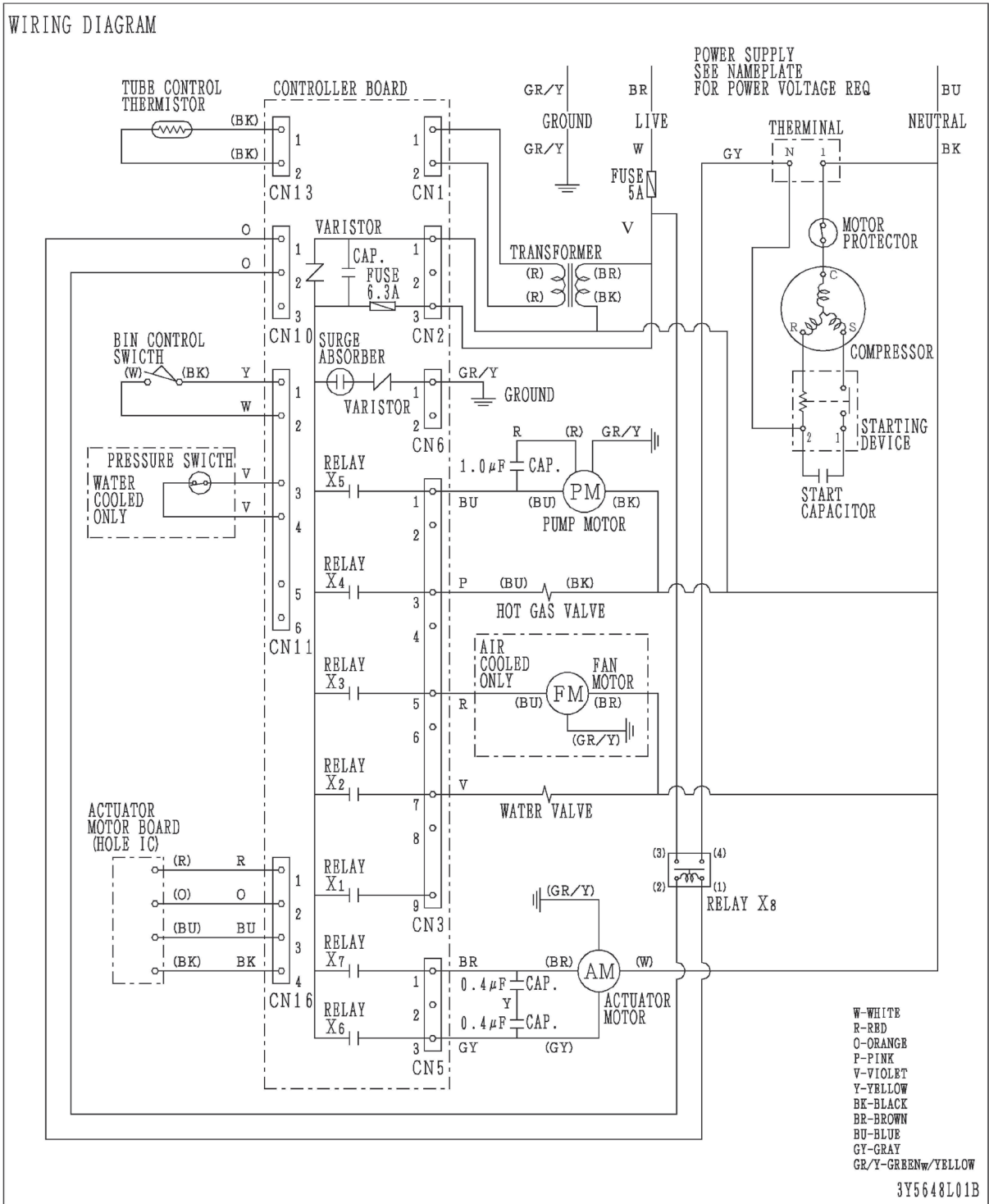

[c] IM-100CNE, IM-100NE, IM-100WNE, IM-130NE, IM-130WNE

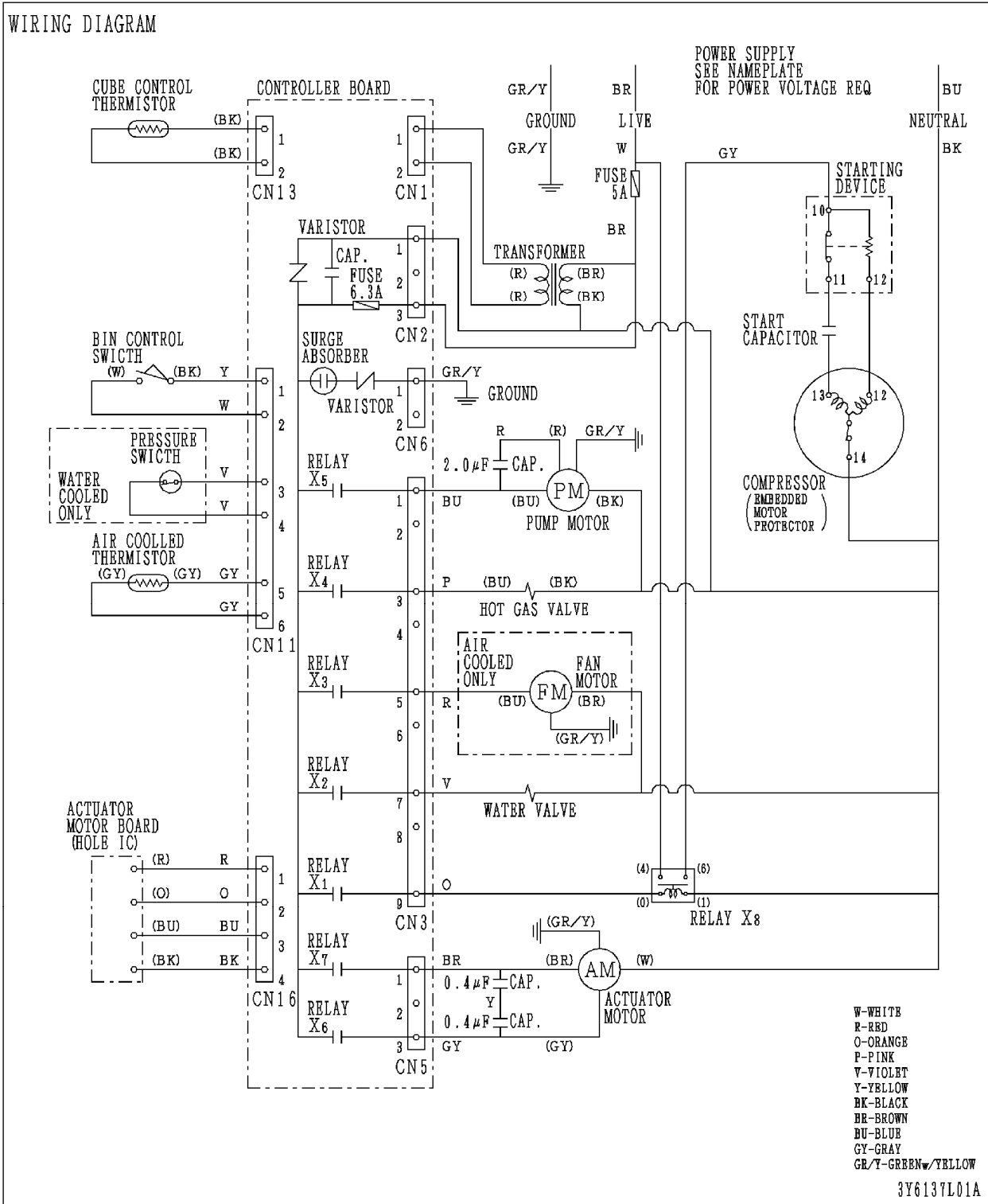

[d] IM-240NE, IM-240WNE

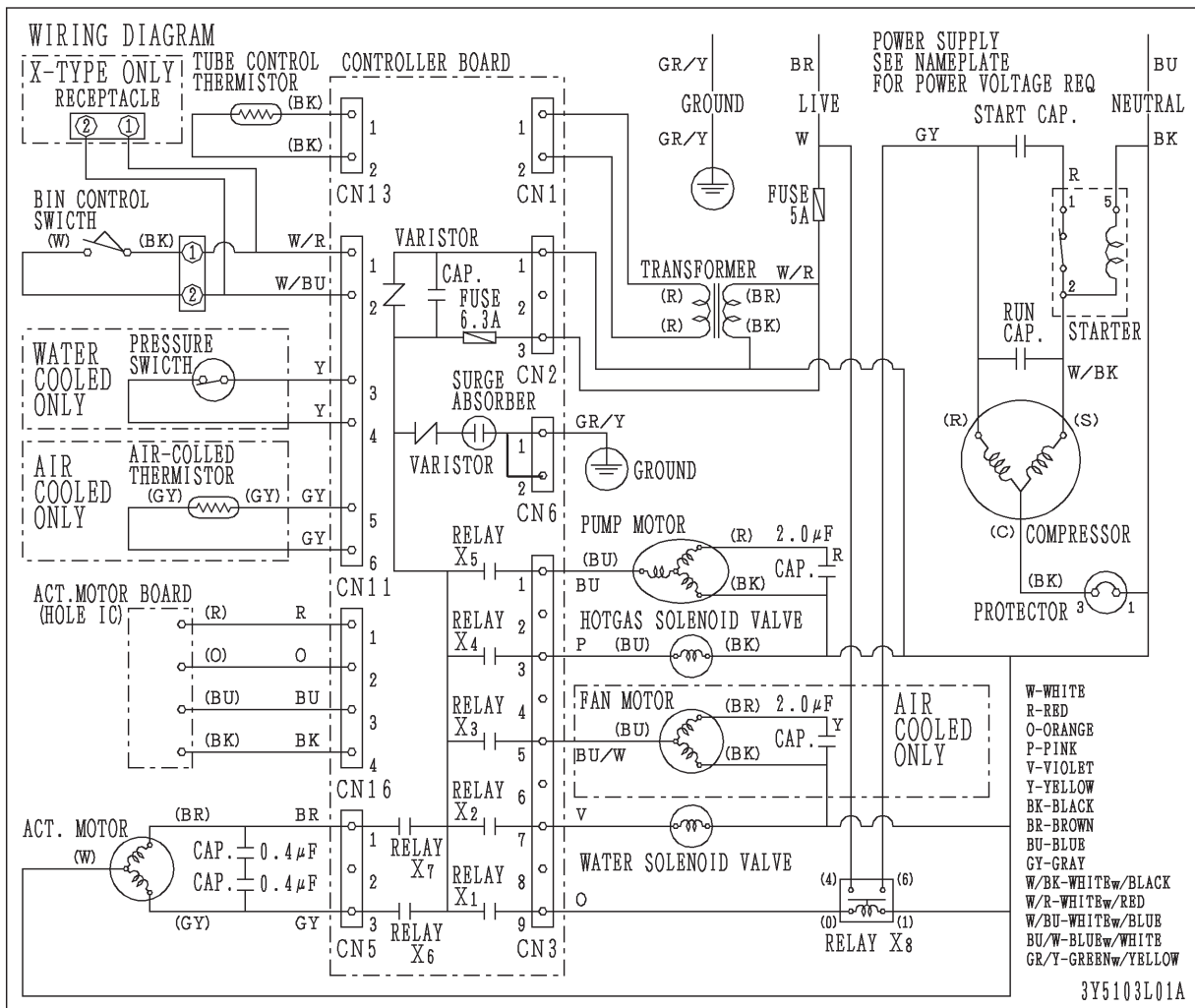

3. PERFORMANCE DATA

Ice Production = Capacity when shipped from factory

Values for water-cooled models are for icemaking water only. Use a cooling tower for cooling water.

Cube Hole Diameter: 5mm (15mm) for -28, -23, -32 3mm (7mm) for -21 6mm for -Q ball ice (45mm dia)
5mm for -S star ice, -H heart ice 10mm for -LM, -LM103

Model	Ambient Temp. (°C)	10	21	32	38
	Water Temp. (°C)	10	15	21	32
	Cube Hole Diameter (mm)	5 (15)	5 (15)	5 (15)	5 (15)
IM-21CNE	Ice Production (kg/d)	20 (22)	17 (19)	14 (16)	12 (14)
	Freeze Cycle Time (min)	23.0 (21.7)	30.4 (17.5)	39.0 (34.1)	45.0 (39.2)
	Defrost Cycle Time (min)	5.8 (4.5)	3.5 (2.8)	2.1 (1.9)	2.0 (1.9)
	Water Consumption (lit/h)	3.4 (3.6)	1.7 (1.8)	1.4 (1.6)	1.2 (1.4)
	Electric Consumption (W)	200	220	240	250
	Head Pressure [peak] (bar)	5.1	7.6	10.2	12.8
IM-30CNE	Ice Production (kg/d)	23 (28)	22 (24)	18 (19)	15 (16)
	Freeze Cycle Time (min)	21.0 (13.5)	23.8 (17.7)	30.0 (23.1)	36.5 (27.9)
	Defrost Cycle Time (min)	4.0 (3.5)	2.4 (2.1)	2.0 (1.9)	1.9 (1.8)
	Water Consumption (lit/h)	4.0 (5.8)	2.2 (2.9)	1.8 (2.3)	1.5 (1.9)
	Electric Consumption (W)	240	250	270	280
	Head Pressure [peak] (bar)	5.1	7.6	10.2	12.8
IM-30CNE (60Hz)	Ice Production (kg/d)	24 (27)	23 (24)	20 (21)	16 (17)
	Freeze Cycle Time (min)	20.5 (14.6)	23.0 (17.8)	27.2 (21.0)	34.4 (26.4)
	Defrost Cycle Time (min)	4.0 (3.5)	2.0 (2.0)	1.6 (1.6)	1.6 (1.6)
	Water Consumption (lit/h)	4.1 (5.6)	2.3 (2.9)	2.0 (2.5)	1.6 (2.0)
	Electric Consumption (W)	240	250	270	280
	Head Pressure [peak] (bar)	5.1	7.6	10.2	12.8
IM-30CNE-25	Ice Production (kg/d)	22 (24)	18 (20)	15 (17)	11 (13)
	Freeze Cycle Time (min)	13.7 (9.7)	19.2 (13.7)	23.9 (16.7)	33.4 (22.6)
	Defrost Cycle Time (min)	4.0 (3.5)	2.4 (2.1)	2.0 (1.9)	1.9 (1.8)
	Water Consumption (lit/h)	5.6 (7.5)	2.6 (3.6)	2.2 (3.1)	1.6 (2.3)
	Electric Consumption (W)	240	250	270	280
	Head Pressure [peak] (bar)	5.1	7.6	10.2	12.8
IM-30CWNE	Ice Production (kg/d)	28 (32)	26 (30)	24 (28)	22 (26)
	Freeze Cycle Time (min)	18.5 (16.0)	20.1 (17.3)	22.0 (18.9)	24.3 (20.6)
	Defrost Cycle Time (min)	2.1 (2.0)	2.1 (1.9)	2.0 (1.7)	1.9 (1.6)
	Water Consumption (lit/h)	4.8 (5.5)	2.6 (2.9)	2.4 (2.7)	2.2 (2.5)
	Electric Consumption (W)	235	235	245	340
	Head Pressure [peak] (bar)	10.0	10.0	10.0	10.0
IM-30CWNE-25	Ice Production (kg/d)	24 (25)	22 (23)	21 (22)	20 (21)
	Freeze Cycle Time (min)	14.0 (10.7)	15.4 (11.9)	16.7 (12.7)	17.6 (13.3)
	Defrost Cycle Time (min)	2.1 (2.0)	2.1 (1.9)	2.0 (1.8)	1.8 (1.7)
	Water Consumption (lit/h)	4.3 (7.0)	5.5 (6.9)	2.8 (3.6)	2.7 (3.4)
	Electric Consumption (W)	235	235	245	340
	Head Pressure [peak] (bar)	10.0	10.0	10.0	10.0
IM-30CWNE (60Hz)	Ice Production (kg/d)	25 (28)	24 (27)	22 (26)	19 (24)
	Freeze Cycle Time (min)	19.8 (14.4)	22.4 (15.3)	24.2 (15.8)	28.5 (17.4)
	Defrost Cycle Time (min)	2.1 (2.0)	2.0 (2.0)	1.9 (1.9)	1.8 (1.8)
	Water Consumption (lit/h)	4.1 (5.5)	2.1 (3.0)	2.0 (2.9)	1.7 (2.7)
	Electric Consumption (W)	219	233	245	251
	Head Pressure [peak] (bar)	10.0	10.0	10.0	10.0
IM-45CNE	Ice Production (kg/d)	36 (44)	32 (40)	29 (32)	26 (29)
	Freeze Cycle Time (min)	22.5 (15.8)	27.5 (19.5)	31.1 (25.0)	35.2 (28.0)
	Defrost Cycle Time (min)	4.3 (3.8)	2.7 (2.1)	2.2 (2.0)	1.9 (1.8)
	Water Consumption (lit/h)	7.0 (9.6)	3.8 (5.4)	3.5 (4.3)	3.1 (3.9)
	Electric Consumption (W)	295	315	320	370
	Head Pressure [peak] (bar)	6.0	9.0	12.0	15.0

Model	Ambient Temp. (°C)	10	21	32	38
	Water Temp. (°C)	10	15	21	32
	Cube Hole Diameter (mm)	5 (15)	5 (15)	5 (15)	5 (15)
IM-45CNE-25	Ice Production (kg/d)	35 (39)	32 (35)	27 (28)	24 (25)
	Freeze Cycle Time (min)	18.1 (13.3)	21.7 (16.6)	27.2 (22.4)	31.0 (25.2)
	Defrost Cycle Time (min)	4.5 (4.1)	3.1 (2.7)	2.1 (1.8)	2.0 (1.9)
	Water Consumption (lit/h)	8.3 (10.8)	4.7 (6.0)	4.0 (4.8)	3.5 (4.3)
	Electric Consumption (W)	290	305	330	360
	Head Pressure [peak] (bar)	6.0	9.0	12.0	15.0
IM-45CNE (60Hz)	Ice Production (kg/d)	41 (46)	37 (40)	33 (36)	30 (33)
	Freeze Cycle Time (min)	18.9 (14.8)	23.3 (19.3)	27.0 (22.1)	30.1 (24.4)
	Defrost Cycle Time (min)	4.6 (4.0)	2.8 (2.3)	2.2 (1.9)	2.1 (1.8)
	Water Consumption (lit/h)	8.0 (9.7)	4.4 (5.2)	4.0 (4.8)	3.6 (4.4)
	Electric Consumption (W)	310	340	360	380
	Head Pressure [peak] (bar)	6.0	9.0	12.0	15.0
IM-45NE-25	Ice Production (kg/d)	35 (39)	32 (35)	27 (28)	24 (25)
	Freeze Cycle Time (min)	18.5 (13.9)	21.7 (16.6)	27.2 (22.4)	31.1 (25.3)
	Defrost Cycle Time (min)	4.1 (3.5)	3.1 (2.7)	2.1 (1.8)	1.9 (1.8)
	Water Consumption (lit/h)	8.3 (10.8)	4.7 (6.0)	4.0 (4.8)	3.5 (4.3)
	Electric Consumption (W)	290	305	330	360
	Head Pressure [peak] (bar)	6.0	9.0	12.0	15.0
IM-45NE (60Hz)	Ice Production (kg/d)	41 (46)	37 (40)	33 (36)	26 (29)
	Freeze Cycle Time (min)	19.1 (14.9)	23.3 (18.9)	27.0 (22.1)	35.2 (28.0)
	Defrost Cycle Time (min)	4.4 (3.9)	2.8 (2.7)	2.2 (1.9)	1.9 (1.8)
	Water Consumption (lit/h)	8.0 (9.7)	4.4 (5.3)	4.0 (4.8)	3.1 (3.9)
	Electric Consumption (W)	310	340	360	390
	Head Pressure [peak] (bar)	6.0	9.0	12.0	15.0
IM-45NE-25 (60Hz)	Ice Production (kg/d)	38 (41)	36 (39)	31 (34)	27 (30)
	Freeze Cycle Time (min)	16.9 (12.9)	18.1 (15.3)	23.5 (18.2)	27.4 (20.9)
	Defrost Cycle Time (min)	3.9 (3.6)	3.9 (2.1)	2.0 (1.7)	1.9 (1.7)
	Water Consumption (lit/h)	9.0 (11.2)	5.3 (6.1)	4.5 (5.7)	4.0 (5.1)
	Electric Consumption (W)	310	340	360	390
	Head Pressure [peak] (bar)	6.0	9.0	12.0	15.0
IM-45WNE	Ice Production (kg/d)	45 (47)	38 (40)	35 (37)	32 (34)
	Freeze Cycle Time (min)	19.5 (17.7)	23.6 (21.2)	25.8 (23.1)	28.5 (25.5)
	Defrost Cycle Time (min)	1.9 (1.9)	1.8 (1.8)	1.8 (1.8)	1.7 (1.6)
	Water Consumption (lit/h)	8.8 (9.6)	4.6 (5.0)	4.2 (4.7)	3.8 (4.3)
	Electric Consumption (W)	275	280	295	315
	Head Pressure [peak] (bar)	10.0	10.0	10.0	10.0
IM-45WNE-25	Ice Production (kg/d)	40 (49)	38 (45)	36 (42)	34 (38)
	Freeze Cycle Time (min)	17.6 (11.8)	18.9 (13.3)	20.2 (14.6)	21.6 (16.2)
	Defrost Cycle Time (min)	2.2 (2.0)	2.0 (1.8)	1.8 (1.6)	1.7 (1.6)
	Water Consumption (lit/h)	7.5 (13.4)	9.8 (13.4)	5.3 (7.1)	5.0 (6.5)
	Electric Consumption (W)	275	280	295	315
	Head Pressure [peak] (bar)	10.0	10.0	10.0	10.0
IM-45WNE (60Hz)	Ice Production (kg/d)	45 (50)	41 (45)	39 (43)	36 (40)
	Freeze Cycle Time (min)	19.1 (16.2)	21.5 (18.5)	22.8 (19.6)	25 (21.3)
	Defrost Cycle Time (min)	2.3 (2.2)	2.0 (2.0)	1.9 (1.8)	1.8 (1.7)
	Water Consumption (lit/h)	8.8 (10.2)	4.9 (5.7)	4.7 (5.4)	4.3 (5.0)
	Electric Consumption (W)	300	305	310	320
	Head Pressure [peak] (bar)	10.0	10.0	10.0	10.0

Model	Ambient Temp. (°C)	10	21	32	38
	Water Temp. (°C)	10	15	21	32
	Cube Hole Diameter (mm)	5 (15)	5 (15)	5 (15)	5 (15)
IM-45WNE-25 (60Hz)	Ice Production (kg/d)	39 (43)	40 (42)	37 (41)	46 (40)
	Freeze Cycle Time (min)	18.3 (13.8)	18.5 (14.4)	19.7 (14.9)	20.3 (15.3)
	Defrost Cycle Time (min)	2.0 (1.9)	1.8 (1.7)	1.7 (1.6)	1.7 (1.6)
	Water Consumption (lit/h)	9.3 (11.9)	5.7 (7.2)	5.4 (7.0)	5.3 (6.8)
	Electric Consumption (W)	300	305	310	320
	Head Pressure [peak] (bar)	10.0	10.0	10.0	10.0
IM-65NE	Ice Production (kg/d)	50 (63)	47 (56)	39 (46)	35 (42)
	Freeze Cycle Time (min)	21.4 (15.0)	25.9 (19.7)	32.6 (24.9)	36.7 (27.2)
	Defrost Cycle Time (min)	5.7 (4.4)	2.9 (2.2)	2.1 (1.7)	2.0 (1.9)
	Water Consumption (lit/h)	7.1 (9.3)	4.7 (6.0)	3.9 (5.0)	3.5 (4.7)
	Electric Consumption (W)	320	340	400	420
	Head Pressure [peak] (bar)	5.0	7.0	10.0	12.5
IM-65NE-Q φ45mm	Ice Production (kg/d)	26	24	20	17
	Freeze Cycle Time (min)	29.6	33.2	42.2	53.8
	Defrost Cycle Time (min)	7.5	7.0	6.0	3.0
	Water Consumption (lit/h)	40.4	29.9	18.7	10.0
	Electric Consumption (W)	320	350	390	420
	Head Pressure [peak] (bar)	5.0	7.0	10.0	12.5
IM-65NE-H	Ice Production (kg/d)	28	27	25	22
	Freeze Cycle Time (min)	18.9	22.7	27.2	29.7
	Defrost Cycle Time (min)	7.1	5.0	3.1	3.5
	Water Consumption (lit/h)	6.2	4.8	4.4	4.0
	Electric Consumption (W)	330	340	370	390
	Head Pressure [peak] (bar)	5.5	7.0	10.5	12.5
IM-65NE-S	Ice Production (kg/d)	22	21	20	19
	Freeze Cycle Time (min)	15.1	18.5	21.9	24.8
	Defrost Cycle Time (min)	8.5	6.5	4.0	2.5
	Water Consumption (lit/h)	17.0	4.8	4.6	4.4
	Electric Consumption (W)	340	350	400	450
	Head Pressure [peak] (bar)	5.5	7.0	10.5	12.5
IM-65NE-LM	Ice Production (kg/d)	40	33	25	20
	Freeze Cycle Time (min)	43.8	61.6	79.4	90
	Defrost Cycle Time (min)	8.0	5.5	3.5	2.5
	Water Consumption (lit/h)	36.4	3.2	2.6	1.7
	Electric Consumption (W)	340	350	400	450
	Head Pressure [peak] (bar)	5.5	7.0	10.5	12.5
IM-65NE-LM103	Ice Production (kg/d)	32	28	23	18
	Freeze Cycle Time (min)	55.8	71.2	86.7	90
	Defrost Cycle Time (min)	9.0	6.5	3.5	2.5
	Water Consumption (lit/h)	32.8	2.8	2.5	1.7
	Electric Consumption (W)	340	350	400	450
	Head Pressure [peak] (bar)	5.5	7.0	10.5	12.5
IM-65NE-LM (60Hz)	Ice Production (kg/d)	43	33	28	24
	Freeze Cycle Time (min)	40.7	57.8	70.6	83.1
	Defrost Cycle Time (min)	7.5	5.0	3.5	2.5
	Water Consumption (lit/h)	33.3	3.3	2.9	70.6
	Electric Consumption (W)	340	370	410	465
	Head Pressure [peak] (bar)	5.5	7.0	10.5	12.5

Model	Ambient Temp. (°C)	10	21	32	38
	Water Temp. (°C)	10	15	21	32
	Cube Hole Diameter (mm)	5 (15)	5 (15)	5 (15)	5 (15)
IM-65NE-LM103 (60Hz)	Ice Production (kg/d)	33	30	26	23
	Freeze Cycle Time (min)	54.8	64.1	75.8	87.7
	Defrost Cycle Time (min)	8.0	5.0	4.0	2.5
	Water Consumption (lit/h)	27.9	2.9	2.5	2.2
	Electric Consumption (W)	370	410	450	525
	Head Pressure [peak] (bar)	5.5	7.0	10.5	12.5
IM-65NE-25	Ice Production (kg/d)	45 (56.)	44 (52)	37 (42)	35 (38)
	Freeze Cycle Time (min)	15.8 (13.8)	21.5 (16.7)	25.9 (21.0)	27.6 (23.5)
	Defrost Cycle Time (min)	7.2 (3.4)	2.1 (1.9)	2.1 (2.0)	2.0 (1.9)
	Water Consumption (lit/h)	9.0 (9.9)	6.6 (8.3)	5.6 (6.8)	5.3 (6.1)
	Electric Consumption (W)	320	340	400	420
	Head Pressure [peak] (bar)	5.0	7.0	10.0	12.5
IM-65NE (60Hz)	Ice Production (kg/d)	55 (62)	52 (58)	43 (47)	40 (44)
	Freeze Cycle Time (min)	19.9 (15.9)	23.1 (18.9)	29.6 (24.4)	32.0 (26.1)
	Defrost Cycle Time (min)	4.7 (3.8)	2.9 (2.2)	1.9 (1.6)	1.8 (1.7)
	Water Consumption (lit/h)	8.5 (10.1)	6.0 (7.2)	5.0 (5.9)	4.6 (5.6)
	Electric Consumption (W)	325	350	370	400
	Head Pressure [peak] (bar)	5.0	7.0	10.0	12.5
IM-65NE-25 (60Hz)	Ice Production (kg/d)	50 (59)	47 (52)	40 (44)	37.0 (41)
	Freeze Cycle Time (min)	16.0 (13.7)	19.7 (16.5)	23.9 (20.2)	26.0 (21.6)
	Defrost Cycle Time (min)	4.7 (2.7)	2.4 (2.1)	2.0 (1.7)	1.9 (1.9)
	Water Consumption (lit/h)	10.0 (11.3)	7.1 (8.3)	6.0 (7.0)	5.6 (6.6)
	Electric Consumption (W)	325	350	370	400
	Head Pressure [peak] (bar)	5.0	7.0	10.0	12.5
IM-65NE-Q (60Hz)	Ice Production (kg/d)	29	26	20	16
	Freeze Cycle Time (min)	24.4	29.9	42.1	54.8
	Defrost Cycle Time (min)	8.1	5.8	5.6	5.5
	Water Consumption (lit/h)	44.8	32.4	19.0	24.1
	Electric Consumption (W)	290	340	355	365
	Head Pressure [peak] (bar)	4.6	7.6	10.2	19.4
IM-65WNE-25	Ice Production (kg/d)	50 (60)	46 (54)	42 (49)	40 (47)
	Freeze Cycle Time (min)	18.7 (14.2)	20.7 (16.1)	22.7 (18.1)	23.9 (18.9)
	Defrost Cycle Time (min)	2.0 (1.9)	2.0 (1.8)	2.0 (1.6)	2.0 (1.6)
	Water Consumption (lit/h)	7.1 (11.6)	9.9 (12.4)	5.5 (6.8)	5.2 (6.6)
	Electric Consumption (W)	350	360	370	400
	Head Pressure [peak] (bar)	10.0	10.0	10.0	10.0
IM-65WNE-Q	Ice Production (kg/d)	26	25	22	19
	Freeze Cycle Time (min)	31.4	33.5	39.1	44.8
	Defrost Cycle Time (min)	5.0	4.8	4.8	4.5
	Water Consumption (lit/h)	31.4	16.1	10.9	9.2
	Electric Consumption (W)	330	340	350	356
	Head Pressure [peak] (bar)	10.0	10.0	10.0	10.0
IM-65WNE (60Hz)	Ice Production (kg/d)	57 (67)	56 (58)	52 (54)	50 (52)
	Freeze Cycle Time (min)	18.0 (14.4)	22.5 (19.6)	24.4 (21.1)	25.5 (21.9)
	Defrost Cycle Time (min)	2.0 (1.7)	1.7 (1.6)	1.6 (1.6)	1.6 (1.6)
	Water Consumption (lit/h)	8.1 (10.0)	5.6 (6.4)	5.2 (6.0)	3.5 (5.8)
	Electric Consumption (W)	300	305	310	320
	Head Pressure [peak] (bar)	10.0	10.0	10.0	10.0

Model	Ambient Temp. (°C)	10	21	32	38
	Water Temp. (°C)	10	15	21	32
	Cube Hole Diameter (mm)	5 (15)	5 (15)	5 (15)	5 (15)
IM-65WNE-25 (60Hz)	Ice Production (kg/d)	58 (66)	57 (58)	52 (53)	50 (55)
	Freeze Cycle Time (min)	15.9 (12.9)	16.5 (15.0)	18.3 (16.6)	19.1 (15.9)
	Defrost Cycle Time (min)	2.0 (1.7)	1.7 (1.6)	1.6 (1.6)	1.6 (1.6)
	Water Consumption (lit/h)	11.6 (13.9)	8.6 (9.3)	7.8 (8.6)	7.5 (8.9)
	Electric Consumption (W)	300	305	310	320
	Head Pressure [peak] (bar)	10.0	10.0	10.0	10.0
IM-100NE	Ice Production (kg/d)	85 (95)	83 (93)	73 (84)	65 (70)
	Freeze Cycle Time (min)	25.1 (20.0)	28.3 (23.2)	33.2 (26.4)	38.0 (32.1)
	Defrost Cycle Time (min)	5.4 (5.0)	2.9 (2.3)	2.3 (1.9)	1.9 (1.8)
	Water Consumption (lit/h)	17.7 (21.3)	8.3 (9.9)	7.3 (9.1)	6.5 (7.6)
	Electric Consumption (W)	540	570	630	640
	Head Pressure [peak] (bar)	6.5	9.0	12.0	15.0
IM-100NE-C	Ice Production (kg/d)	77 (85)	74 (81)	65 (71)	60 (66)
	Freeze Cycle Time (min)	28.4 (22.0)	31.6 (25.1)	38.5 (31.2)	42.4 (34.2)
	Defrost Cycle Time (min)	6.2 (6.0)	4.4 (4.2)	2.5 (2.3)	2.0 (1.8)
	Water Consumption (lit/h)	16.2 (10.7)	8.3 (10.2)	6.3 (7.8)	5.9 (7.2)
	Electric Consumption (W)	540	570	630	640
	Head Pressure [peak] (bar)	6.5	9.0	12.0	15.0
IM-100NE-23	Ice Production (kg/d)	72 (79)	71 (77)	67 (70)	65 (70)
	Freeze Cycle Time (min)	20.9 (16.5)	22.8 (18.7)	25.9 (22.5)	27.0
	Defrost Cycle Time (min)	5.1 (5.0)	3.6 (3.4)	2.0 (1.8)	1.8 (1.7)
	Water Consumption (lit/h)	20.8 (25.0)	9.9 (11.7)	9.3 (10.6)	9.0 (10.7)
	Electric Consumption (W)	540	570	630	640
	Head Pressure [peak] (bar)	6.5	9.0	12.0	15.0
IM-100NE-21	Ice Production (kg/d)	87 (98)	86 (95)	76 (87)	71 (78)
	Freeze Cycle Time (min)	12.3 (9.4)	15.9 (12.4)	20 (15)	21.6 (16.9)
	Defrost Cycle Time (min)	5.0 (4.0)	3.4 (2.8)	1.8 (1.6)	1.7 (1.6)
	Water Consumption (lit/h)	28.4 (34.4)	13.5 (16.5)	11.9 (15.5)	11.7 (14.0)
	Electric Consumption (W)	540	570	630	640
	Head Pressure [peak] (bar)	6.5	9.0	12.0	15.0
IM-100NE (60Hz)	Ice Production (kg/d)	88 (98)	85 (93)	75 (83)	70 (75)
	Freeze Cycle Time (min)	24.5 (19.9)	26.9 (22.5)	32.4 (26.7)	35.0 (29.8)
	Defrost Cycle Time (min)	5.0 (4.3)	3.6 (3.0)	2.2 (1.9)	2.0 (1.9)
	Water Consumption (lit/h)	18.3 (21.6)	8.5 (9.9)	7.5 (9.0)	7.0 (8.2)
	Electric Consumption (W)	610	630	650	660
	Head Pressure [peak] (bar)	6.5	9.0	12.0	15.0
IM-100NE-23 (60Hz)	Ice Production (kg/d)	75 (81)	73 (79)	69 (75)	65 (70)
	Freeze Cycle Time (min)	20.0 (16.1)	22.1 (18.2)	25.0 (20.9)	26.9 (22.5)
	Defrost Cycle Time (min)	5.0 (4.9)	3.5 (3.3)	2.1 (1.8)	1.9 (1.8)
	Water Consumption (lit/h)	21.6 (25.6)	10.1 (12.0)	9.6 (11.3)	9.0 (10.7)
	Electric Consumption (W)	610	630	650	660
	Head Pressure [peak] (bar)	6.5	9.0	12.0	15.0
IM-100NE-21 (60Hz)	Ice Production (kg/d)	87 (98)	86 (95)	76 (87)	71 (78)
	Freeze Cycle Time (min)	14.0 (10.7)	16.0 (12.5)	19.9 (14.9)	21.5 (16.8)
	Defrost Cycle Time (min)	5.0 (4.0)	3.3 (2.7)	1.9 (1.7)	1.8 (1.7)
	Water Consumption (lit/h)	28.4 (34.4)	13.5 (16.5)	11.9 (15.5)	11.1
	Electric Consumption (W)	610	630	650	660
	Head Pressure [peak] (bar)	6.5	9.0	12.0	15.0
IM-100WNE	Ice Production (kg/d)	90 (97)	86 (95)	78 (88)	70 (75)
	Freeze Cycle Time (min)	25.6 (21.8)	27.4 (22.7)	30.9 (24.9)	34.7 (29.5)
	Defrost Cycle Time (min)	3.2 (2.7)	2.7 (2.3)	2.3 (2.1)	2.3 (2.2)
	Water Consumption (lit/h)	18.8 (21.6)	8.6 (10.2)	7.8 (9.6)	7.0 (8.2)
	Electric Consumption (W)	520	530	540	550
	Head Pressure [peak] (bar)	10.5	10.5	10.5	10.5

Model	Ambient Temp. (°C)	10	21	32	38
	Water Temp. (°C)	10	15	21	32
	Cube Hole Diameter (mm)	5 (15)	5 (15)	5 (15)	5 (15)
IM-100WNE-23	Ice Production (kg/d)	77 (84)	73 (80)	71 (78)	69 (76)
	Freeze Cycle Time (min)	22.1 (18.2)	23.1 (19.3)	24.2 (19.9)	25.1 (20.6)
	Defrost Cycle Time (min)	2.3 (2.0)	2.3 (2.0)	2.2 (1.9)	2.0 (1.8)
	Water Consumption (lit/h)	20.6 (26.4)	13.7 (16.1)	9.9 (11.8)	9.6 (11.6)
	Electric Consumption (W)	520	530	540	550
	Head Pressure [peak] (bar)	10.5	10.5	10.5	10.5
IM-100WNE-21	Ice Production (kg/d)	87 (96)	84 (88)	79 (82)	74 (81)
	Freeze Cycle Time (min)	16.8 (13.0)	17.6 (14.5)	19.0 (15.9)	20.1 (15.6)
	Defrost Cycle Time (min)	2.2 (2.0)	2.1 (1.9)	2.0 (1.7)	2.3 (2.2)
	Water Consumption (lit/h)	28.4 (35.5)	13.2 (15.7)	12.4 (14.6)	11.6 (14.6)
	Electric Consumption (W)	520	530	540	550
	Head Pressure [peak] (bar)	10.5	10.5	10.5	10.5
IM-100WNE (60Hz)	Ice Production (kg/d)	95 (104)	90 (98)	84 (92)	76 (83)
	Freeze Cycle Time (min)	23.9 (19.9)	26.1 (21.9)	28.5 (23.5)	31.8 (26.4)
	Defrost Cycle Time (min)	3.4 (2.9)	2.7 (2.3)	2.4 (2.3)	2.3 (2.2)
	Water Consumption (lit/h)	19.8 (23.1)	9.0 (10.5)	8.4 (10.0)	7.6 (9.1)
	Electric Consumption (W)	560	580	600	620
	Head Pressure [peak] (bar)	10.5	10.5	10.5	10.5
IM-100WNE-21 (60Hz)	Ice Production (kg/d)	94 (103)	88 (97)	85 (94)	82 (90)
	Freeze Cycle Time (min)	15.3 (12.0)	16.7 (13.0)	17.6 (13.7)	18.4 (14.3)
	Defrost Cycle Time (min)	2.3 (2.0)	2.1 (1.8)	1.9 (1.6)	1.8 (1.7)
	Water Consumption (lit/h)	30.7 (37.8)	13.8 (17.2)	13.3 (16.6)	12.9 (16.3)
	Electric Consumption (W)	560	580	600	620
	Head Pressure [peak] (bar)	10.5	10.5	10.5	10.5
IM-130NE	Ice Production (kg/d)	100 (130)	104 (112)	88 (96)	75 (82)
	Freeze Cycle Time (min)	19.0 (14.5)	22.4 (19.0)	27.4 (23.0)	32.9 (27.4)
	Defrost Cycle Time (min)	6.9 (3.8)	2.5 (2.2)	2.1 (1.8)	1.7 (1.6)
	Water Consumption (lit/h)	20.8 (25.3)	10.4 (12.1)	8.8 (10.4)	7.5 (8.9)
	Electric Consumption (W)	610	650	700	720
	Head Pressure [peak] (bar)	12.5	16.0	21.0	24.5
IM-130NE-23	Ice Production (kg/d)	90 (100)	86 (90)	75 (76)	70 (75)
	Freeze Cycle Time (min)	15.6 (12.9)	19.0 (16.6)	23.0 (20.9)	24.8 (20.9)
	Defrost Cycle Time (min)	5.2 (4.1)	2.6 (2.3)	2.0 (1.8)	1.9 (1.7)
	Water Consumption (lit/h)	26.0 (29.8)	12.0 (13.6)	10.4 (11.5)	9.7 (11.5)
	Electric Consumption (W)	610	650	700	720
	Head Pressure [peak] (bar)	12.5	16.0	21.0	24.5
IM-130WNE	Ice Production (kg/d)	110 (127)	105 (117)	95 (105)	90 (99)
	Freeze Cycle Time (min)	19.9 (15.7)	21.6 (17.7)	24.9 (20.6)	26.8 (22.1)
	Defrost Cycle Time (min)	3.7 (3.0)	3.1 (2.6)	2.4 (2.0)	2.0 (1.9)
	Water Consumption (lit/h)	22.9 (27.8)	10.5 (12.5)	9.5 (11.3)	9.0 (10.8)
	Electric Consumption (W)	610	650	700	720
	Head Pressure [peak] (bar)	19.5	19.5	19.5	19.5
IM-130WNE-23	Ice Production (kg/d)	90 (100)	91 (95)	90 (92)	87 (89)
	Freeze Cycle Time (min)	17.6 (14.0)	17.9 (15.4)	18.6 (16.5)	19.5 (17.3)
	Defrost Cycle Time (min)	3.2 (3.0)	2.7 (2.5)	2.2 (1.9)	2.0 (1.8)
	Water Consumption (lit/h)	26.0 (31.8)	12.6 (19.3)	12.2 (13.9)	11.7 (13.6)
	Electric Consumption (W)	610	650	700	720
	Head Pressure [peak] (bar)	19.5	19.5	19.5	19.5
IM-100CNE	Ice Production (kg/d)	85 (95)	83 (93)	73 (84)	65 (70)
	Freeze Cycle Time (min)	25.6 (21.1)	28.5 (23.4)	33.6 (26.6)	38.0 (32.1)
	Defrost Cycle Time (min)	4.9 (3.9)	2.7 (2.1)	1.9 (1.7)	1.9 (1.8)
	Water Consumption (lit/h)	17.7 (20.8)	8.3 (9.9)	7.3 (9.1)	6.5 (7.7)
	Electric Consumption (W)	555	570	630	640
	Head Pressure [peak] (bar)	6.5	9.0	12.0	15.0

Model	Ambient Temp. (°C)	10	21	32	38
	Water Temp. (°C)	10	15	21	32
	Cube Hole Diameter (mm)	5 (15)	5 (15)	5 (15)	5 (15)
IM-100CNE-23	Ice Production (kg/d)	72 (79)	71 (77)	67 (70)	65 (70)
	Freeze Cycle Time (min)	20.9 (16.5)	23.4 (19.5)	26.1 (22.6)	27.0 (22.6)
	Defrost Cycle Time (min)	5.1 (5.0)	3.0 (2.6)	1.8 (1.7)	1.8 (1.7)
	Water Consumption (lit/h)	20.8 (25.0)	9.9 (11.6)	9.3 (10.7)	9.0 (10.7)
	Electric Consumption (W)	555	570	630	640
	Head Pressure [peak] (bar)	6.5	9.0	12.0	15.0
IM-100CNE-21	Ice Production (kg/d)	90 (92)	85 (87)	62 (64)	60 (62)
	Freeze Cycle Time (min)	14.9 (12.5)	16.8 (14.3)	24.7 (20.7)	25.7 (21.5)
	Defrost Cycle Time (min)	3.5 (3.2)	2.7 (2.3)	2.0 (1.8)	1.9 (1.7)
	Water Consumption (lit/h)	29.3 (33.9)	13.3 (15.3)	9.7 (11.5)	9.4 (11.2)
	Electric Consumption (W)	555	570	630	640
	Head Pressure [peak] (bar)	6.5	9.0	12.0	15.0
IM-100CNE (60Hz)	Ice Production (kg/d)	88 (98)	85 (93)	75 (83)	70 (75)
	Freeze Cycle Time (min)	23.9 (18.8)	26.2 (21.4)	32.6 (26.8)	35.0 (29.8)
	Defrost Cycle Time (min)	5.6 (5.4)	4.3 (4.1)	2.0 (1.8)	2.0 (1.9)
	Water Consumption (lit/h)	18.3 (22.3)	8.5 (10.2)	7.5 (9.1)	7.0 (8.2)
	Electric Consumption (W)	610	630	650	660
	Head Pressure [peak] (bar)	6.5	9.0	12.0	15.0

[a] COPELAND COMPRESSOR

Ice Production = Capacity when shipped from factory

Values for water-cooled models are for icemaking water only. Use a cooling tower for cooling water.

Cube Hole Diameter: 5mm (15mm) for -28, -23, -32 3mm (7mm) for -21 6mm for -Q ball ice (45mm dia)
5mm for -S star ice, -H heart ice 10mm for -LM, -LM103

Model	Ambient Temp. (°C)	10	21	32	38
	Water Temp. (°C)	10	15	21	32
	Cube Hole Diameter (mm)	5 (15)	5 (15)	5 (15)	5 (15)
IM-240NE	Ice Production (kg/d)	230 (240)	210 (230)	195 (210)	170 (195)
	Freeze Cycle Time (min)	15.9 (14.3)	19.5 (16.7)	21.6 (18.9)	25.3 (20.5)
	Defrost Cycle Time (min)	4.1 (3.7)	2.4 (2.1)	2.0 (1.7)	1.8 (1.7)
	Water Consumption (lit/h)	31.3 (34.1)	14.9 (17.2)	13.9 (15.7)	12.1 (14.7)
	Electric Consumption (W)	1195	1270	1320	1450
	Head Pressure [peak] (bar)	14.0	17.0	21.0	25.0
IM-240NE-23	Ice Production (kg/d)	185 (225)	175 (215)	165 (195)	155 (185)
	Freeze Cycle Time (min)	14.6 (10.8)	17.1 (13.0)	19.0 (15.2)	20.3 (15.0)
	Defrost Cycle Time (min)	3.9 (3.7)	2.5 (2.2)	1.8 (1.6)	1.8 (1.7)
	Water Consumption (lit/h)	33.9 (42.6)	16.7 (21.2)	15.8 (19.3)	14.8 (18.5)
	Electric Consumption (W)	1195	1270	1320	1450
	Head Pressure [peak] (bar)	14.0	17.0	21.0	25.0
IM-240WNE	Ice Production (kg/d)	230 (240)	215 (225)	205 (215)	185 (195)
	Freeze Cycle Time (min)	17.9 (16.0)	19.4 (17.3)	20.7 (18.4)	23.2 (20.6)
	Defrost Cycle Time (min)	2.1 (2.0)	2.0 (1.9)	1.8 (1.7)	1.7 (1.6)
	Water Consumption (lit/h)	31.3 (34.7)	15.3 (17.0)	14.6 (16.2)	13.2 (14.7)
	Electric Consumption (W)	1250	1250	1300	1300
	Head Pressure [peak] (bar)	19.5	19.7	19.8	20.0

Suction Pressure and Evaporator Temp.

50/60 Hz

Model	Ambient Temp. (°C)	10	21	32	38
	Water Temp. (°C)	10	15	21	32
IM-21_NE	Suction Pressure Peak (bar)	0.4	1.0	1.5	2.1
	Evaporator Inlet Temp. (°C)	-17	-17	-16	-15
IM-30_NE	Suction Pressure Peak (bar)	0.4	1.0	1.5	2.1
	Evaporator Inlet Temp. (°C)	-17	-17	-16	-15
IM-45_NE	Suction Pressure Peak (bar)	0.7	1.1	1.6	2.1
	Evaporator Inlet Temp. (°C)	-19	-18	-15	-14
IM-65_NE	Suction Pressure Peak (bar)	0.7	1.0	1.3	1.7
	Evaporator Inlet Temp. (°C)	-16	-16	-13	-12
IM-65NE-Q (60Hz)	Suction Pressure Peak (bar)	0.7	1.0	1.3	1.7
	Evaporator Inlet Temp. (°C)	-23	-20	-17	-12
IM-65WNE-Q	Suction Pressure Peak (bar)	0.7	1.0	1.3	1.5
	Evaporator Inlet Temp. (°C)	-19	-17	-19	-15
IM-100_NE	Suction Pressure Peak (bar)	1.2	1.5	1.8	2.2
	Evaporator Inlet Temp. (°C)	-17	-17	-14	-12
IM-130_NE	Suction Pressure Peak (bar)	3.0	3.5	4.0	5.0
	Evaporator Inlet Temp. (°C)	-20	-19	-18	-17
IM-240_NE	Suction Pressure Peak (bar)	3.0	3.5	4.0	5.0
	Evaporator Inlet Temp. (°C)	-20	-19	-18	-17
IM-100_NE-21	Suction Pressure Peak (bar)	1.2	1.5	1.8	2.2
	Evaporator Inlet Temp. (°C)	-13	-11	-10	-9.0
IM-100_NE-23	Suction Pressure Peak (bar)	1.2	1.5	1.8	2.2
	Evaporator Inlet Temp. (°C)	-17	-17	-14	-12
IM-130_NE-23	Suction Pressure Peak (bar)	3.0	3.5	4.0	5.0
	Evaporator Inlet Temp. (°C)	-20	-19	-18	-17
IM-240_NE-21	Suction Pressure Peak (bar)	3.0	3.5	4.0	5.0
	Evaporator Inlet Temp. (°C)	-13	-11	-10	-9
IM-240_NE-23	Suction Pressure Peak (bar)	3.0	3.5	4.0	5.0
	Evaporator Inlet Temp. (°C)	-20	-19	-18	-17
IM-240_NE-32	Suction Pressure Peak (bar)	3.0	3.5	4.0	5.0
	Evaporator Inlet Temp. (°C)	-23	-22	-21	-20

Note: The above data are only for reference in servicing. Actual readings may be slightly different for each product.

Suction Pressure = Peak readings in freezing cycle

Evaporator Inlet Temp. = 5 minutes before completion of freezing cycle

[b] SECOP (DANFOSS) COMPRESSOR

Ice Production = Capacity when shipped from factory

Values for water-cooled models are for icemaking water only. Use a cooling tower for cooling water.

Cube Hole Diameter: 5mm (15mm) for -28, -23, -32 3mm (7mm) for -21

Model	Ambient Temp. (°C)	10	21	32	38
	Water Temp. (°C)	10	15	21	32
	Cube Hole Diameter (mm)	5 (15)	5 (15)	5 (15)	5 (15)
IM-240NE	Ice Production (kg/d)	230 (240)	210 (230)	195 (210)	170 (195)
	Freeze Cycle Time (min)	15.9 (14.3)	19.5 (16.7)	21.6 (18.9)	25.3 (20.5)
	Defrost Cycle Time (min)	4.1 (3.7)	2.4 (2.1)	2.0 (1.7)	1.8 (1.7)
	Water Consumption (lit/h)	31.3 (34.1)	14.9 (17.2)	13.9 (15.7)	12.1 (14.7)
	Electric Consumption (W)	1195	1270	1320	1450
	Head Pressure [peak] (bar)	14.0	17.0	21.0	25.0
IM-240NE-23	Ice Production (kg/d)	185 (225)	175 (215)	165 (195)	155 (185)
	Freeze Cycle Time (min)	14.6 (10.8)	17.1 (13.0)	19.0 (15.2)	20.3 (15.0)
	Defrost Cycle Time (min)	3.9 (3.7)	2.5 (2.2)	1.8 (1.6)	1.8 (1.7)
	Water Consumption (lit/h)	33.9 (42.6)	16.7 (21.2)	15.8 (19.3)	14.8 (18.5)
	Electric Consumption (W)	1195	1270	1320	1450
	Head Pressure [peak] (bar)	14.0	17.0	21.0	25.0
IM-240NE-21	Ice Production (kg/d)	190 (217)	180 (210)	165 (190)	152 (167)
	Freeze Cycle Time (min)	12.3 (8.3)	14.5 (10.2)	16.3 (11.9)	18.1 (13.8)
	Defrost Cycle Time (min)	3.6 (3.6)	2.3 (2.1)	2.0 (1.7)	1.8 (1.7)
	Water Consumption (lit/h)	39.5 (52.6)	19.5 (26.2)	17.9 (23.5)	16.5 (21.0)
	Electric Consumption (W)	1195	1270	1320	1450
	Head Pressure [peak] (bar)	14.0	17.0	21.0	25.0
IM-240WNE	Ice Production (kg/d)	230 (240)	215 (225)	205 (215)	185 (195)
	Freeze Cycle Time (min)	17.9 (16.0)	19.4 (17.3)	20.7 (18.4)	23.2 (20.6)
	Defrost Cycle Time (min)	2.1 (2.0)	2.0 (1.9)	1.8 (1.7)	1.7 (1.6)
	Water Consumption (lit/h)	31.3 (34.7)	15.3 (17.0)	14.6 (16.2)	13.2 (14.7)
	Electric Consumption (W)	1250	1250	1300	1300
	Head Pressure [peak] (bar)	19.5	19.7	19.8	20.0
IM-240WNE-23	Ice Production (kg/d)	185 (210)	175 (202)	168 (185)	150 (165)
	Freeze Cycle Time (min)	15.5 (12.8)	16.6 (13.5)	17.7 (15.1)	20.8 (18.0)
	Defrost Cycle Time (min)	3.0 (2.8)	2.9 (2.7)	2.7 (2.5)	2.5 (2.3)
	Water Consumption (lit/h)	31.7 (39.8)	21.4 (25.4)	16.1 (18.4)	14.4 (16.4)
	Electric Consumption (W)	1250	1250	1300	1330
	Head Pressure [peak] (bar)	19.5	19.7	19.8	20.0

Suction Pressure and Evaporator Temp.

50/60 Hz

Model	Ambient Temp. (°C)	10	21	32	38
	Water Temp. (°C)	10	15	21	32
IM-240_NE	Suction Pressure Peak (bar)	3.0	3.5	4.0	5.0
	Evaporator Inlet Temp. (°C)	-20	-19	-18	-17
IM-240_NE-21	Suction Pressure Peak (bar)	3.0	3.5	4.0	5.0
	Evaporator Inlet Temp. (°C)	-13	-11	-10	-9
IM-240_NE-32	Suction Pressure Peak (bar)	3.0	3.5	4.0	5.0
	Evaporator Inlet Temp. (°C)	-23	-22	-21	-20

Note: The above data are only for reference in servicing. Actual readings may be slightly different for each product.

Suction Pressure = Peak readings in freezing cycle

Evaporator Inlet Temp. = 5 minutes before completion of freezing cycle

VI. SERVICE DIAGNOSIS

1. ERROR CODE INDICATION

* See the controller board service manual for detailed diagnosis and remedies.

* The error and caution codes other than E1 and E2 are indicated as "EE" in the 7-segment display at the time of occurrence. But the error history is recorded as the actual error codes in parenthesis, and a maximum of five errors are indicated from the latest entry.

Error	Item	Description	Operation	Reset
E1	Freeze error	Freeze backup timer (45/60 minutes) counts up before freeze cycle completes, and evaporator temperature is 0°C or higher.	Shut down	Press reset switch
E2	Defrost error	Defrost backup timer (30 minutes) counts up before defrost cycle completes.	Shut down	Press reset switch
EE (E3)	Water pan opening error	Water pan has not fully opened within 60 seconds, and 3 minutes have passed even with opening failure control.	Halt	Press reset switch
		Unit resumes operation after 60 minutes and repeats the above error.	Shut down	
EE (E4)	Water pan closing error	[Controller board before ver. 1.6A] Water pan has not fully closed within 60 seconds, and 3 minutes have passed even with closing failure control.	Halt	Press reset switch
		[Controller board ver. 1.6A and later] Water pan has not fully closed within 50 seconds, opened and started to close again, but failed to close fully within 50 seconds.		
		Unit resumes operation after 60 minutes and repeats the above error.	Shut down	
EE (E5)	High temperature error	Evaporator temperature stays 60°C or higher for 5 seconds or more.	Shut down	Press reset switch
EE (E9)	Condenser thermistor error	Condenser thermistor circuit is open or shorted for 2 seconds.	Shut down	Replace thermistor
EE (EA)	Data error	Model setting data memory IC is defective.	Shut down	Replace controller board
EE (EC)	Cube control thermistor error	Cube control thermistor circuit is open or shorted for 2 seconds.	Shut down	Replace thermistor
EE (Ed)	Water regulator error	Cooling water cannot stop by water regulator error, and thermistor senses set point or lower temperature.	Continue	Press reset switch

Caution	Item	Description	Operation	Reset
EE (C2)	High pressure	[Air-cooled] Condenser thermistor senses 63°C or higher temperature. [Water-cooled] Pressure switch senses 2.65MPa or higher pressure.	Compressor stops	After 5 minutes, condensing temperature 50°C or lower, pressure 1.96MPa or lower

2. NO ERROR CODE INDICATION

Problem	Check	Possible Cause	Remedy
Icemaker will not start.	Power source	Turned off.	Turn on.
		Supply voltage too low.	Remove cause
		Power failure	Wait until power is resumed.
	Transformer	Defective.	Replace.
	Power cord	Not connected properly.	Reconnect.
		Open circuit (damaged).	Replace.
	Controller board	Defective.	Replace.
	Fuse	Blown out.	Check for cause. Replace.
Bin control switch	Stuck on other parts (e.g. ice guide).	Remove ice.	
	Short circuit (display shows "on").	Replace.	
Slab does not break into separate cubes.	Extension spring	Over-extended.	Replace.
	Water plate	Obstacle caught between evaporator and water plate.	Remove obstacle.
Icemaker will not stop when bin is filled with ice.	Bin control switch actuator	Out of position.	Place in position.
		Broken.	Replace.
	Bin control switch	Out of position.	Place in position.
		Broken.	Replace.
	Bin control switch detector	Out of position.	Place in position.
		Broken.	Replace.
Bin control micro switch	Disconnected from switch box.	Reconnect.	
	Seizing with open contacts.	Replace.	
Controller board	Defective.	Replace.	
Cloudy cubes.	Water quality	High hardness.	Set hard water control.
			Switch to full drain flush (see note below).
	Ice condition	Slush ice.	Set slush ice control.
Abnormal noise	Pump motor	Bearing worn out.	Replace.
		Vapor lock.	Clean water valve filter.
			Check water supply cycle time setting.
	Fan motor	Bearing worn out.	Replace.
		Fan touching obstacle.	Remove obstacle.
Actuator motor	Gear worn out.	Replace.	
Cubes drop separately.	Refrigeration circuit	Gas leaks (long defrost cycle).	Repair.
	Cam arm	Worn out.	Replace.

Note:

Full drain flush - After a freeze cycle ends, the unit drains all the remaining water in the tank and refills the tank in the next freeze cycle.

Partial drain flush (default setting) - After a freeze cycle ends, the unit leaves the remaining water in the tank and adds some water to fill the tank in the next freeze cycle.

Problem	Check	Possible Cause	Remedy
Imperfect ice production.	Insufficient water supply	Water valve filter clogged.	Clean.
		Water supply cycle too short.	Extend.
		Water supply pressure too low.	Remove cause.
	Water leaks from water tank or water plate	Water tank broken.	Replace.
		Water plate broken.	Replace.
		Icemaker not level.	Adjust.
	Water valve	Water leaks valve body.	Replace.
		Water leaks from water supply pipe joint.	Check hose clamp. Replace connection hose.
	Water plate	Spray holes clogged.	Unclog.
Pump motor	Defective.	Replace.	
Large-hole cubes.	Refrigeration circuit	Gas leaks (low refrigeration capacity).	Repair.
	Condenser	Not clean (low condensing capacity).	Clean.
		Filter clogged.	Clean.
	Fan motor	Defective.	Replace.
	Installation site	No clearance at right side and rear (air-cooled model only).	Ensure clearance.
		Ambient temperature above 40°C.	Ensure ventilation to lower temperature.
	Power supply	Supply voltage too low (low refrigeration capacity).	Remove cause.
Water valve	Water leaks.	Replace.	
Insufficient water supply	Water supply pressure too low.	Remove cause.	
Freeze cycle time is too long.	Installation site	Ambient temperature too high.	Ensure ventilation to lower temperature.
	Condenser	Not clean (low condensing capacity).	Clean.
		Filter clogged.	Clean.
	Fan motor	Defective.	Replace.
Refrigeration circuit	Gas leaks (low refrigeration capacity).	Repair.	

VII. ADJUSTMENT

1. EXPANSION VALVE

The expansion valve is factory-adjusted. Do not adjust it except at replacement or service. Adjust the valve setting, if necessary, as follows:

- 1) Remove the cap nut.
- 2) Rotate the adjust screw by using a flat blade screwdriver.
- 3) Watch holes of ice cubes produced. Standard setting is that evaporator inlet side and outlet side cubes have almost the same diameters. To make the inlet side larger, rotate 90 - 180° clockwise. Smaller, counterclockwise. Do not rotate more than 180° at a time.

NOTICE

Over adjustment of the valve may result in liquid refrigerant return causing freezing to the suction line and severe damage to the compressor.

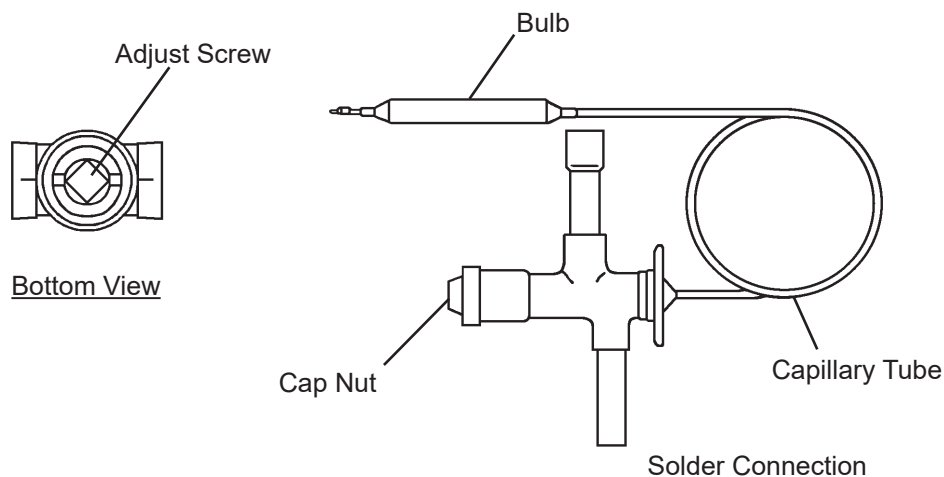

Fig. 9

2. WATER REGULATING VALVE - WATER-COOLED MODEL ONLY

The water regulating valve is factory-adjusted. Do not adjust it except at replacement or service. Adjust the valve setting, if necessary, as follows:

- 1) Attach a pressure gauge to high-side line, or prepare a thermometer to check condenser drain temperature.
- 2) Rotate the adjust screw using a flat blade screwdriver so that the pressure gauge shows 10 bar (IM-30/45/65/100) / 16 bar (IM-130) / 19 bar (IM-240), or the thermometer reads 30 - 40°C (IM-30/45/65/100) / 35 - 40°C (IM-130) / 45 - 50°C (IM-240), 5 minutes after freeze cycle starts.
When the pressure or temperature exceeds the above, rotate the adjust screw counterclockwise.
- 3) Check that the pressure or temperature holds.

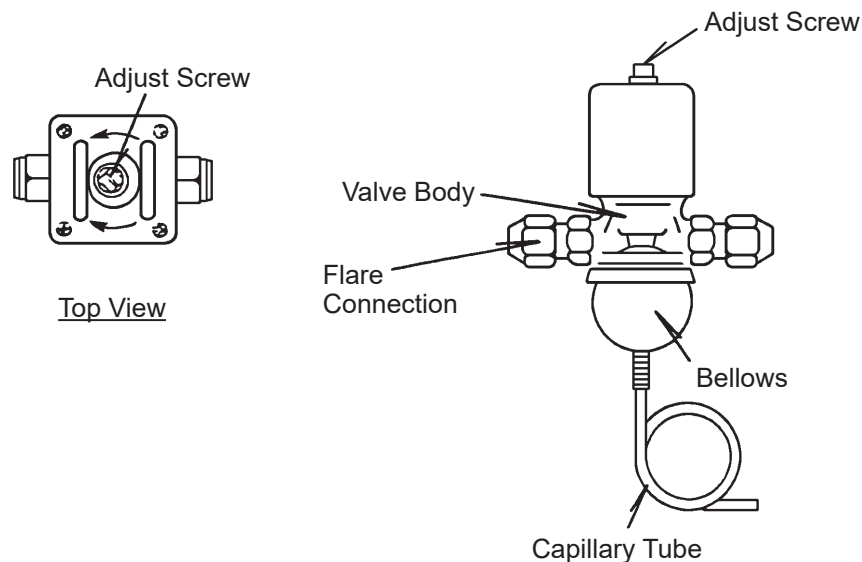

Fig. 10

3. FULL DRAIN FLUSH

In some hard water areas, white ice and scaling can be caused. In such case, install a filter or softener, and change the flush mode from “partial drain flush” to “full drain flush” according to the following instructions.

Full drain flush – After a freeze cycle ends, the unit drains all the remaining water in the tank and refills the tank in the next freeze cycle.

Partial drain flush (default setting) – After a freeze cycle ends, the unit leaves the remaining water in the tank and adds some water to fill the tank in the next freeze cycle.

- 1) Remove the screw located on the front of the water tank. Move the tank drain pipe to the drain position (see Fig. 11). Secure the tank drain pipe with the screw.

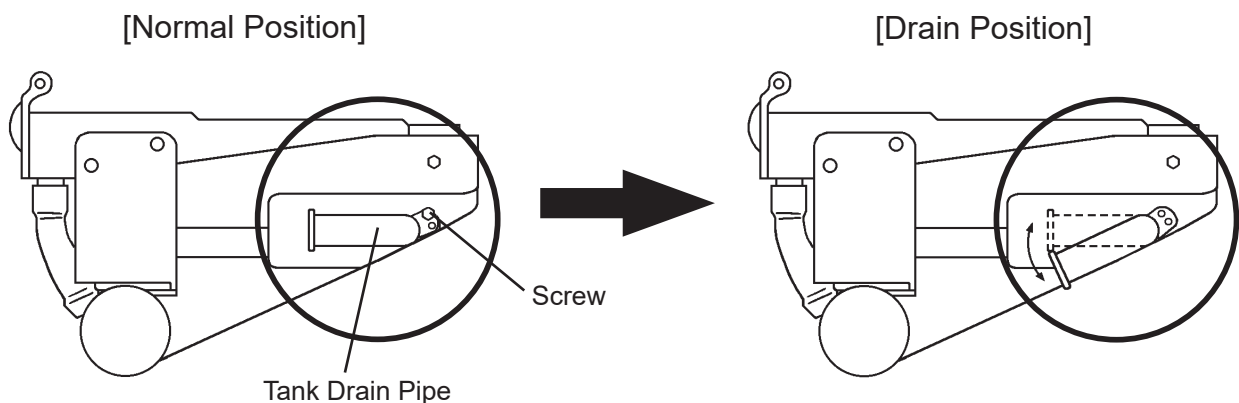

Fig. 11

- 2) Change the following controller board settings from “partial drain flush” to “full drain flush”, referring to “3. [b] MAINTENANCE MODE” in the IM-N series controller board service manual (E1CK-811).

Full / partial drain flush selection – Maintenance mode No. 14 (0: full, 1: partial)

Icemaking water supply time – Maintenance mode No. 12

Additional icemaking water supply time – Maintenance mode No. 15

4. DIMPLE DIAMETER

See “2. [i] DIMPLE DIAMETER SETTING” in the IM-N series controller board service manual (E1CK-811).

VIII. REMOVAL AND REPLACEMENT

1. SERVICE FOR REFRIGERANT LINES

[a] SERVICE INFORMATION

1) Allowable Compressor Opening Time and Prevention of Lubricant Mixture [R134a/R404A]

The compressor must not be opened more than 30 minutes in replacement or service. Do not mix lubricants of different compressors even if both are charged with the same refrigerant, except when they use the same lubricant.

2) Treatment for Refrigerant Leak [R134a/R404A]

If a refrigerant leak occurs in the low side of an ice maker, air may be drawn in. Even if the low side pressure is higher than the atmospheric pressure in normal operation, a continuous refrigerant leak will eventually reduce the low side pressure below the atmospheric pressure and will cause air suction. Air contains a large amount of moisture, and ester oil easily absorbs a lot of moisture. If an ice maker charged with R134a/R404A has possibly drawn in air, the drier must be replaced. Be sure to use a drier designed for R134a/R404A.

3) Handling of Handy Flux [R134a/R404A]

Repair of the refrigerant circuit needs brazing. It is no problem to use the same handy flux that has been used for the current refrigerants. However, its entrance into the refrigerant circuit should be avoided as much as possible.

4) Oil for Processing of Copper Tubing [R134a/R404A]

When processing the copper tubing for service, wipe off oil, if any used, by using alcohol or the like. Do not use too much oil or let it into the tubing, as wax contained in the oil will clog the capillary tubing.

5) Service Parts for R134a/R404A

Some parts used for refrigerants other than R134a/R404A are similar to those for R134a/R404A. But never use any parts unless they are specified for R134a/R404A because their endurance against the refrigerant has not been evaluated. Also, for R134a/R404A, do not use any parts that have been used for other refrigerants. Otherwise, wax and chlorine remaining on the parts may adversely affect the R134a/R404A.

6) Replacement Copper Tubing [R134a/R404A]

The copper tubes currently in use are suitable for R134a/R404A. But do not use them if

oily inside. The residual oil in copper tubes should be as little as possible. (Low residual oil type copper tubes are used in the shipped units.)

7) Evacuation, Vacuum Pump and Refrigerant Charge [R134a/R404A]

Never allow the oil in the vacuum pump to flow backward. The vacuum level and vacuum pump may be the same as those for the current refrigerants. However, the rubber hose and gauge manifold to be used for evacuation and refrigerant charge should be exclusively for R134a/R404A.

8) Refrigerant Leak Check

Refrigerant leaks can be detected by charging the unit with a little refrigerant, raising the pressure with nitrogen and using an electronic detector. Do not use air or oxygen instead of nitrogen for this purpose, or rise in pressure as well as in temperature may cause R134a/R404A to suddenly react with oxygen and explode. Be sure to use nitrogen to prevent explosion.

[b] REFRIGERANT RECOVERY

IM-21, 30, 45, 65, 100 (R134a)

No refrigerant access valve is provided in the unit. A tap valve should initially be fitted to the low-side process tube and be replaced with a proper access valve (see Fig. 12) when recovery is completed.

Recover the refrigerant by using a refrigerant recovery machine (see its instruction manual for proper operation), and store the refrigerant in a proper container. Do not discharge the refrigerant into the atmosphere.

IM-130, 240 (R404A)

A low-side access valve is provided on an extension pipe connected to the suction port of the compressor. A tap valve should initially be fitted to the high-side process tube and be replaced with a proper access valve (see Fig. 12) when recovery is completed.

Recover the refrigerant by using a refrigerant recovery machine (see its instruction manual for proper operation), and store the refrigerant in a proper container. Do not discharge the refrigerant into the atmosphere.

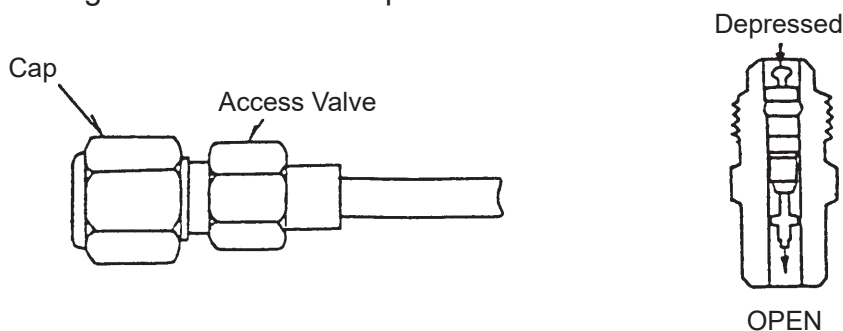

Fig. 12

[c] EVACUATION AND RECHARGE

IM-21, 30, 45, 65, 100 (R134a)

- 1) Attach a charging hose of a gauge manifold to a vacuum pump and the low-side access valve.
- 2) Open the low-side valve on the gauge manifold, and turn on the vacuum pump.
- 3) Allow the vacuum pump to pull down to a 760 mmHg vacuum. Evacuating period depends on the pump capacity.
- 4) Close the low-side valve on the gauge manifold.
- 5) Disconnect the vacuum pump, and attach a refrigerant charging cylinder to accurately weigh in the liquid charge. Remember to purge any air from the charging hose. See the nameplate for the required refrigerant charge.
- 6) Open the low-side valve on the gauge manifold and the valve on the charging cylinder.
- 7) When no more refrigerant is drawn in, turn on the icemaker. When the required amount of refrigerant has been charged, close the valve on the charging cylinder and turn off the icemaker.
- 8) Close the low-side valve on the gauge manifold.
- 9) Disconnect the charging hose from the access valve. Always cap the access valve to prevent a refrigerant leak.
- 10) Always thoroughly leak test all joints and valve caps.
- 11) Avoid charging large quantities of liquid into the low side in case of damage to the compressor.

IM-130, 240 (R404A)

- 1) Attach charging hoses of a gauge manifold to a vacuum pump and the low-side and high-side access valves.
- 2) Open the low-side and high-side valves on the gauge manifold, and turn on the vacuum pump.
- 3) Allow the vacuum pump to pull down to a 760 mmHg vacuum. Evacuating period depends on the pump capacity.
- 4) Close the low-side and high-side valves on the gauge manifold.

- 5) Disconnect the vacuum pump, and attach a refrigerant charging cylinder to accurately weigh in the liquid charge. Remember to purge any air from the charging hose. See the nameplate for the required refrigerant charge.
- 6) Open the high-side valve on the gauge manifold and the valve on the charging cylinder.

Note: Always charge in the liquid stage, as many refrigerants are blends and vapour charging will affect the blend consistency (e.g. R404A).
- 7) When no more refrigerant is drawn in, turn on the icemaker. When the required amount of refrigerant has been charged, close the valve on the charging cylinder and turn off the icemaker.
- 8) Close the high-side valve on the gauge manifold.
- 9) Disconnect the charging hoses from the access valves. Always cap the access valves to prevent a refrigerant leak.
- 10) Always thoroughly leak test all joints and valve caps.
- 11) Avoid charging large quantities of liquid into the low side in case of damage to the compressor.

2. COMPRESSOR

- 1) Unplug the icemaker or disconnect the power source.
- 2) Remove the front and rear panels.
- 3) Recover the refrigerant and store it in a proper container, if required by an applicable law (See "1. [b] REFRIGERANT RECOVERY").
- 4) Remove the terminal cover on the compressor, and disconnect solderless terminals.
- 5) Disconnect the discharge and suction pipes using brazing equipment.
- 6) Remove the hold-down bolts, washers and rubber grommets.
- 7) Slide and remove the compressor. Unpack the new compressor package.
- 8) Attach the rubber grommets of the previous compressor.
- 9) Clean the suction and discharge pipes with an abrasive cloth/paper.
- 10) Place the compressor in position, and secure it using the bolts and washers.

- 11) Remove plugs from the compressor suction and discharge pipes.
- 12) Braze or solder the access, suction and discharge lines (Do not change this order), with nitrogen gas flowing at the pressure of 0.2 - 0.3 bar.
- 13) Install the new drier (See "3. DRIER").
- 14) Check for leaks using nitrogen gas (10 bar) and soap bubbles.
- 15) Evacuate the system and charge it with refrigerant (See "1. [c] EVACUATION AND RECHARGE").
- 16) Connect the solderless terminals and replace the terminal cover in its correct position.
- 17) Replace the panels in their correct positions.
- 18) Plug in the icemaker or connect the power source.

Note: Hoshizaki recommends that compressor starting electrics are always replaced at the same time as the compressor.

3. DRIER

- 1) Unplug the icemaker or disconnect the power source.
- 2) Remove the front and rear panels.
- 3) Recover the refrigerant and store it in a proper container, if required by an applicable law (See "1. [b] REFRIGERANT RECOVERY").
- 4) Remove the drier holder, if any, and pull the drier toward you for easy service.
- 5) Remove the drier using brazing equipment.
- 6) Braze or solder the new drier, with the arrow on the drier in the direction of the refrigerant flow. Use nitrogen gas at the pressure of 0.2 - 0.3 bar when brazing tubings.
- 7) Check for leaks using nitrogen gas (10 bar) and soap bubbles.
- 8) Evacuate the system and charge it with refrigerant (See "1. [c] EVACUATION AND RECHARGE").
- 9) Replace the panels in their correct positions.

10) Plug in the icemaker or connect the power source.

Note: Always use a drier of the correct capacity and refrigerant type.

4. EXPANSION VALVE

IMPORTANT

Always install a new drier every time the sealed refrigeration system is opened. Do not replace the drier until after all other repair or replacement has been made.

- 1) Unplug the icemaker or disconnect the power source.
- 2) Remove the front and rear panels.
- 3) Recover the refrigerant and store it in a proper container, if required by an applicable law (See "1. [b] REFRIGERANT RECOVERY").
- 4) Remove the expansion valve using brazing equipment. Protect the evaporator and pipes from excessive heat with damp cloths or similar.
- 5) Remove the expansion valve sensor (bulb).
- 6) Remove the drier using brazing equipment.
- 7) Braze in the new expansion valve. Protect the body of the valve from excessive heat, and use nitrogen at a pressure of 0.2 - 0.3 bar when brazing.
- 8) Braze or solder the new drier (See "3. DRIER").
- 9) Check for leaks using nitrogen gas (10 bar) and soap bubbles.
- 10) Evacuate the system and charge it with refrigerant (See "1. [c] EVACUATION AND RECHARGE").
- 11) Attach the bulb to the suction line in position. Be sure to secure it using a wire or clamp and replace the insulation.
- 12) Replace the panels in their correct positions.
- 13) Plug in the icemaker or connect the power source.

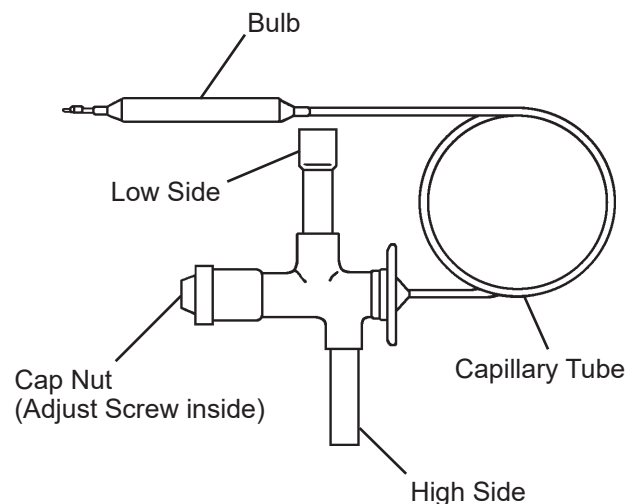

5. EVAPORATOR

IMPORTANT

Always install a new drier every time the sealed refrigeration system is opened. Do not replace the drier until after all other repair or replacement has been made.

- 1) Unplug the icemaker or disconnect the power source.
- 2) Remove the front and rear panels.
- 3) Recover the refrigerant and store it in a proper container, if required by an applicable law (See "1. [b] REFRIGERANT RECOVERY").
- 4) Remove the water pan assembly, referring to "8. WATER PAN ASSEMBLY".
- 5) Disconnect the solder connections on the evaporator using brazing equipment. Protect the expansion valve from excessive heat.
- 6) Remove four nuts holding the evaporator.
- 7) Install the new evaporator, and secure it with the bolts, collars (spacer) and nuts.
- 8) Install the new drier (See "3. DRIER").
- 9) Braze pipes, with nitrogen gas flowing at the pressure of 0.2 - 0.3 bar.
- 10) Check for leaks using nitrogen gas (10 bar) and soap bubbles.
- 11) Evacuate the system and charge it with refrigerant (See "1. [c] EVACUATION AND RECHARGE").
- 12) Replace the removed panels in their correct positions.
- 13) Plug in the icemaker or connect the power source.

6. HOT GAS VALVE

IMPORTANT

Always install a new drier every time the sealed refrigeration system is opened. Do not replace the drier until after all other repair or replacement has been made.

- 1) Unplug the icemaker or disconnect the power source.
- 2) Remove the front and rear panels.
- 3) Recover the refrigerant and store it in a proper container, if required by an applicable law (See "1. [b] REFRIGERANT RECOVERY").
- 4) Disconnect the hot gas valve leads.
- 5) Remove the screw and the solenoid coil.
- 6) Remove the valve and drier using brazing equipment.
- 7) Braze the new hot gas valve with nitrogen gas flowing at the pressure of 0.2 - 0.3 bar.

WARNING

Always protect the valve body by using a damp cloth to prevent the valve from overheating. Do not braze with the valve body exceeding 120°C.

- 8) Install the new drier (See "3. DRIER").
- 9) Check for leaks using nitrogen gas (10 bar) and soap bubbles.
- 10) Evacuate the system and charge it with refrigerant (See "1. [c] EVACUATION AND RECHARGE").
- 11) Attach the solenoid coil to the valve body, and secure it with the screw.
- 12) Connect the leads.
- 13) Replace the panels in their correct positions.
- 14) Plug in the icemaker or connect the power source.

7. WATER REGULATING VALVE - WATER-COOLED MODEL ONLY

[a] VALVE BODY

- 1) Unplug the icemaker or disconnect the power source.
- 2) Close the water supply tap.
- 3) Remove the front and rear panels.
- 4) Disconnect the flare connections of the water regulating valve.
- 5) Remove the valve from the bracket.
- 6) Install a new water regulating valve.
- 7) Connect the flare connections.
- 8) Open the water supply tap.
- 9) Check for water leaks.
- 10) Replace the panels in their correct positions.
- 11) Plug in the icemaker or connect the power source.

[b] WHOLE VALVE

IMPORTANT

Always install a new drier every time the sealed refrigeration system is opened. Do not replace the drier until after all other repair or replacement has been made.

- 1) Unplug the icemaker or disconnect the power source.
- 2) Close the water supply tap.
- 3) Remove the front and rear panels.
- 4) Recover the refrigerant and store it in a proper container, if required by an applicable law (See "1. [b] REFRIGERANT RECOVERY").
- 5) Cut off the copper tube near the capillary tube solder connection, using a pipe cutter.

- 6) Cut off the capillary tubes of the valve and high-pressure switch, using a file and pliers. Be careful not to damage the capillary tube end.
- 7) Disconnect the flare connections from the bracket.
- 8) Remove the screws and the valve from the bracket.
- 9) Install the new valve, and insert the capillary tubes into the copper tube.
- 10) Web the copper tube end, and braze or solder the copper tube and capillary tubes together.
- 11) Install the new drier (See “3. DRIER”).
- 12) Check for leaks using nitrogen gas (10 bar) and soap bubbles.
- 13) Evacuate the system and charge it with refrigerant (See “1. [c] EVACUATION AND RECHARGE”).
- 14) Connect the flare connections.
- 15) Open the water supply tap.
- 16) Check for water leaks.
- 17) Replace the panels in their correct positions.
- 18) Plug in the icemaker or connect the power source.

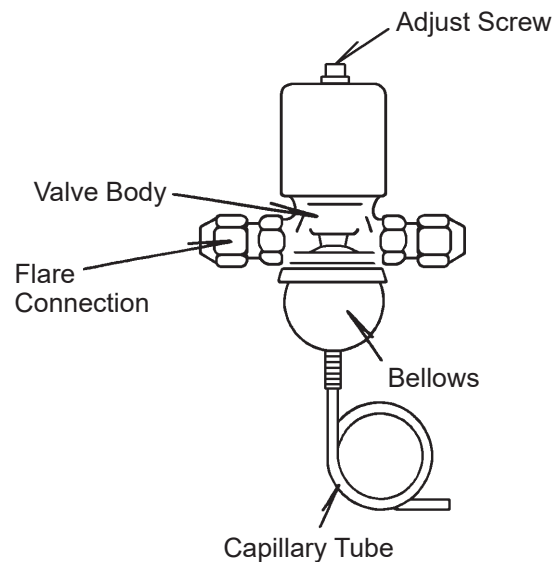

Fig. 14

8. WATER PAN ASSEMBLY

- 1) Remove the top and front panels.
- 2) Push the reset switch on the control box to open the water pan.
- 3) Unplug the icemaker or disconnect the power source.
- 4) Disconnect the pump motor leads in the wiring channel.
- 5) Remove the two extension springs from the cams.
- 6) Remove the water plate bracket and the water pan assembly.
- 7) Remove the two spring hook screws from the water tank.
- 8) Remove the screws and the water plate bracket.
- 9) Remove the pump suction and discharge tubings.
- 10) Remove the pump motor bracket from the water plate.
- 11) Install the new water plate or water tank in the reverse order of the removal procedure.
- 12) Replace the panels in their correct positions.
- 13) Plug in the icemaker or connect the power source.

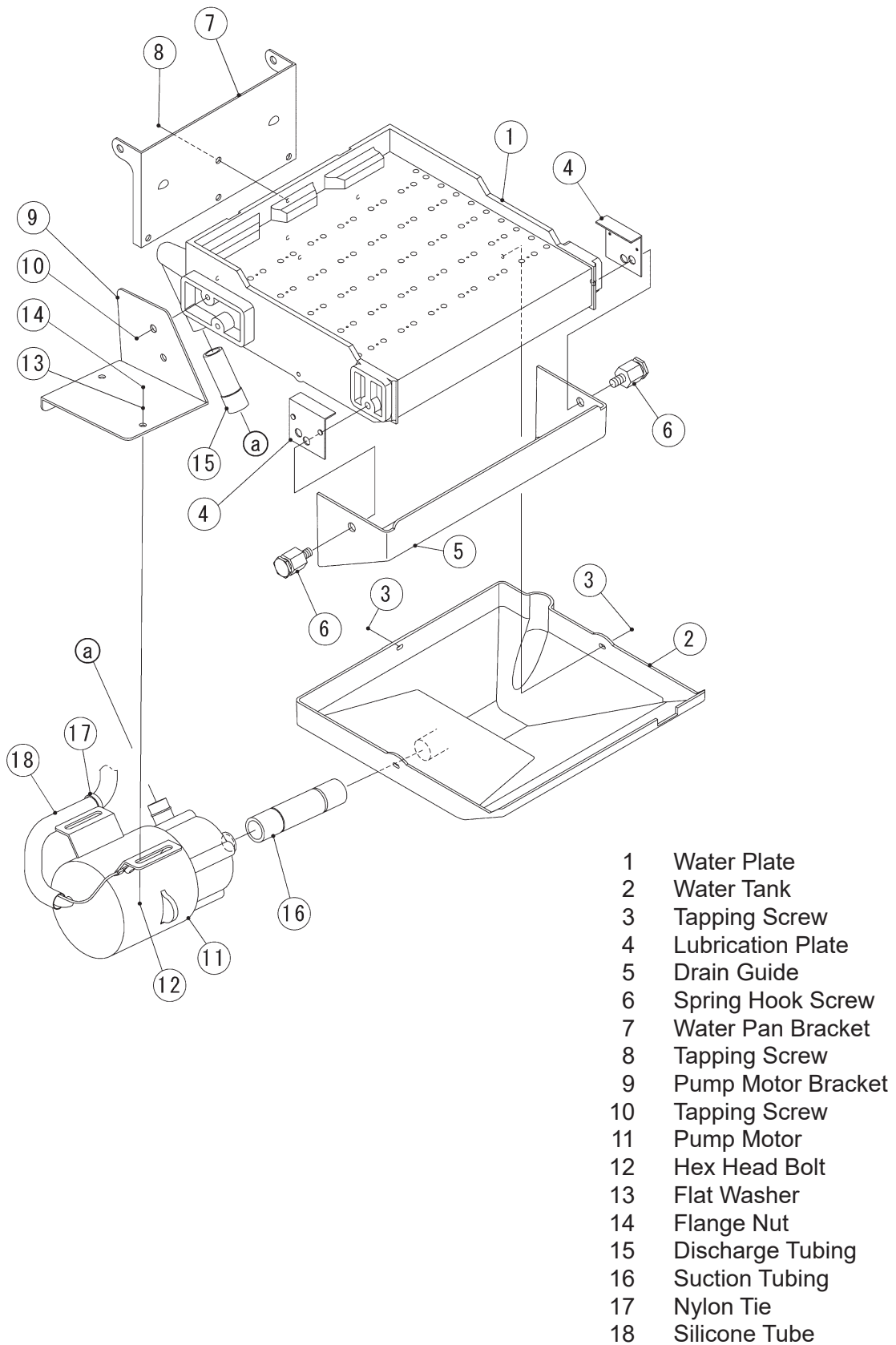

Fig. 15

9. PUMP MOTOR

- 1) Unplug the icemaker or disconnect the power source.
- 2) Remove the top panel and front panel.
- 3) Disconnect the pump motor leads in the wiring channel.
- 4) Unscrew and remove the pump motor from the bracket.
- 5) Disconnect the pump suction and discharge tubings.
- 6) Install the new motor in the reverse order of the removal procedure.
- 7) Plug in the icemaker or connect the power source, and check for leaks.
- 8) Replace the panels in their correct positions.

10. WATER VALVE

- 1) Close the water supply tap.
- 2) Unplug the icemaker or disconnect the power source.
- 3) Remove the top panel and front panel.
- 4) Disconnect the receptacle (leads) from the water valve.
- 5) Remove the valve outlet tubing by releasing the clamp.
- 6) Remove the inlet hose and water valve.
- 7) Install the new valve in the reverse order of the removal procedure.
- 8) Open the water supply tap.
- 9) Plug in the icemaker or connect the power source.
- 10) Check for leaks.
- 11) Replace the panels in their correct positions.

Note: When replacing parts, disassemble as shown in Fig. 7 and replace the defective parts.

11. ACTUATOR MOTOR

- 1) Remove the top panel and front panel.
- 2) Push the reset switch on the control box to open the water pan.
- 3) Unplug the icemaker or disconnect the power source.
- 4) Remove the extension spring (actuator motor side) from the cam.
- 5) Disconnect the actuator motor leads in the wiring channel.
- 6) Remove the actuator motor bracket.
- 7) Remove the spring pin securing the shaft to the cam.
- 8) Remove the actuator motor.
- 9) Install the new actuator motor in the reverse order of the removal procedure.
- 10) Check that the cam can move in the proper range.
- 11) Replace the panels in their correct positions.
- 12) Plug in the icemaker or connect the power source.

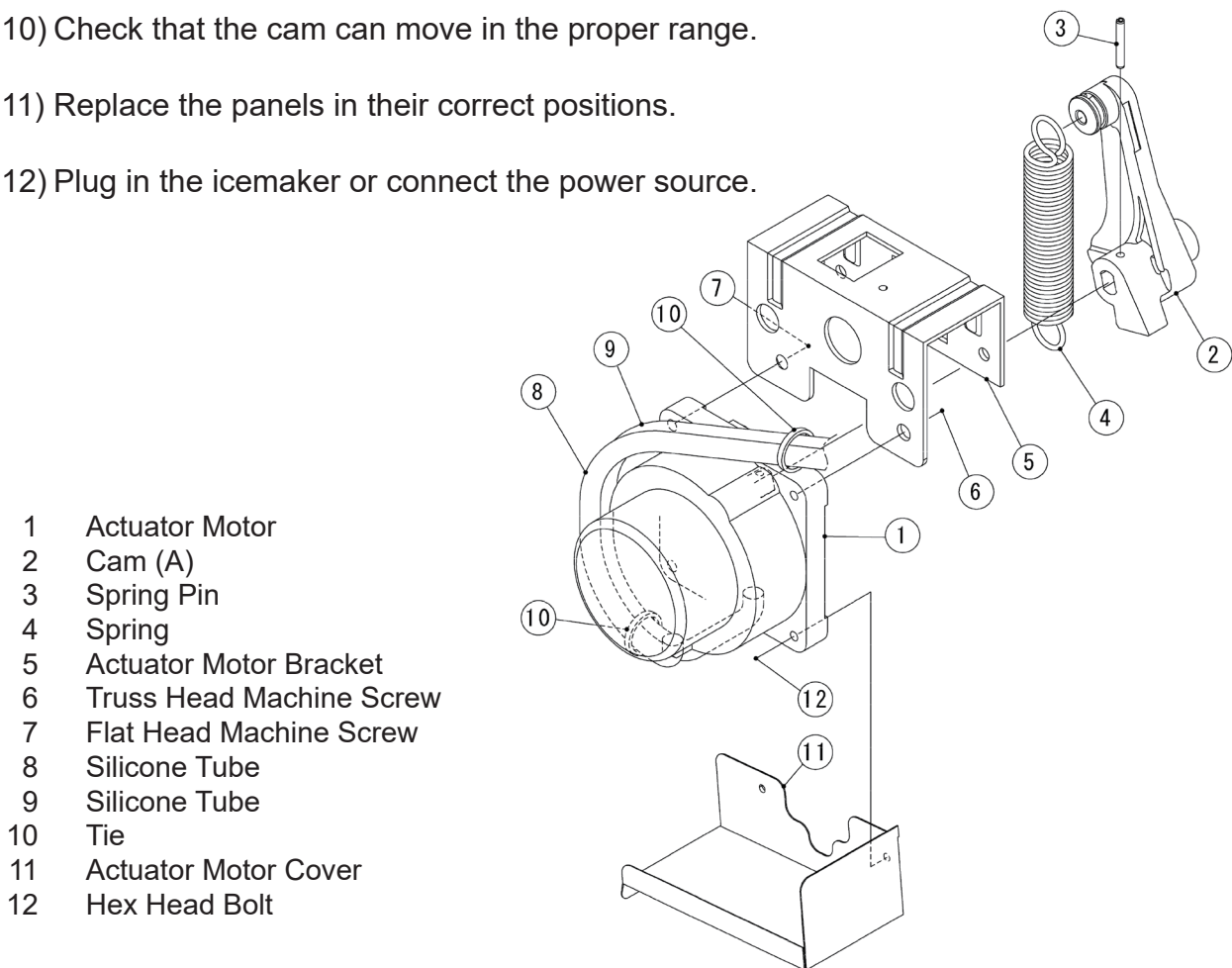

Fig. 16

12. CAM

[a] CAM (A) - ACTUATOR MOTOR SIDE

Refer to “11. ACTUATOR MOTOR”.

[b] CAM (B) - REAR SIDE

- 1) Remove the top panel and front panel.
- 2) Push the reset switch on the control box to open the water pan.
- 3) Unplug the icemaker or disconnect the power source.
- 4) Remove the extension spring from the cam (B).
- 5) Remove the split pin from the cam shaft.
- 6) Remove the cam (B).
- 7) Install the new cam in the reverse order of the removal procedure.
- 8) Replace the panels in their correct positions.
- 9) Plug in the icemaker or connect the power source.

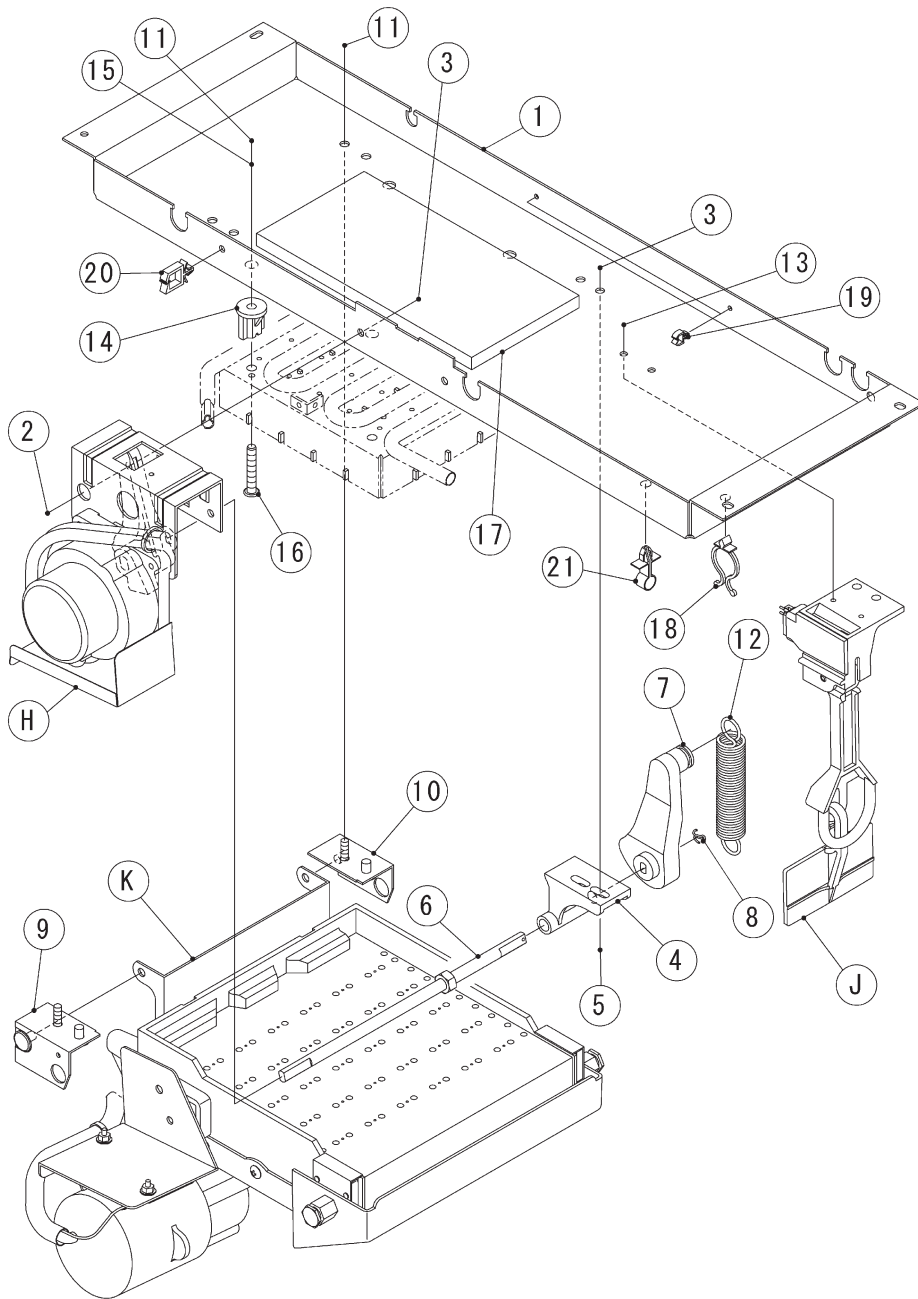

- H Actuator Motor Assembly
- J Bin Switch Assembly
- K Water Pan Assembly
- 1 Ice Making Mechanism Bracket
- 2 Machine Screw
- 3 Flange Nut
- 4 Cam Shaft Bearing
- 5 Machine Screw
- 6 Cam Shaft
- 7 Cam (B)
- 8 Cotter Pin
- 9 Water Pan Bearing (Front)
- 10 Water Pan Bearing (Rear)
- 11 Flange Nut
- 12 Spring
- 13 Tapping Screw
- 14 Spacer
- 15 Washer
- 16 Evaporator Screw
- 17 Insulation (D)
- 18 Clamp
- 19 Clamp
- 20 Wire Saddle
- 21 Clamp

Fig. 17

13. CONTROLLER BOARD

IMPORTANT

Some adjustment will be required for the controller board to fit the icemaker models. Do not repair any parts and electronic devices on the controller board in the field. Replace the whole board with a new service board.

- 1) Unplug the icemaker or disconnect the power source.
- 2) Remove the front panel.
- 3) Unscrew and remove the control box cover.
- 4) Disconnect all the connectors from the controller board.
- 5) Remove the controller board from the four board supports for connection to the control box.
- 6) Install the new controller board in the reverse order of the removal procedure.
- 7) Replace the front panel in its correct position.
- 8) Plug in the icemaker or connect the power source.
- 9) The icemaker restarts in the model setting mode. Set the model code according to the controller board service manual.

IM-21CNE, 30CNE/CWNE

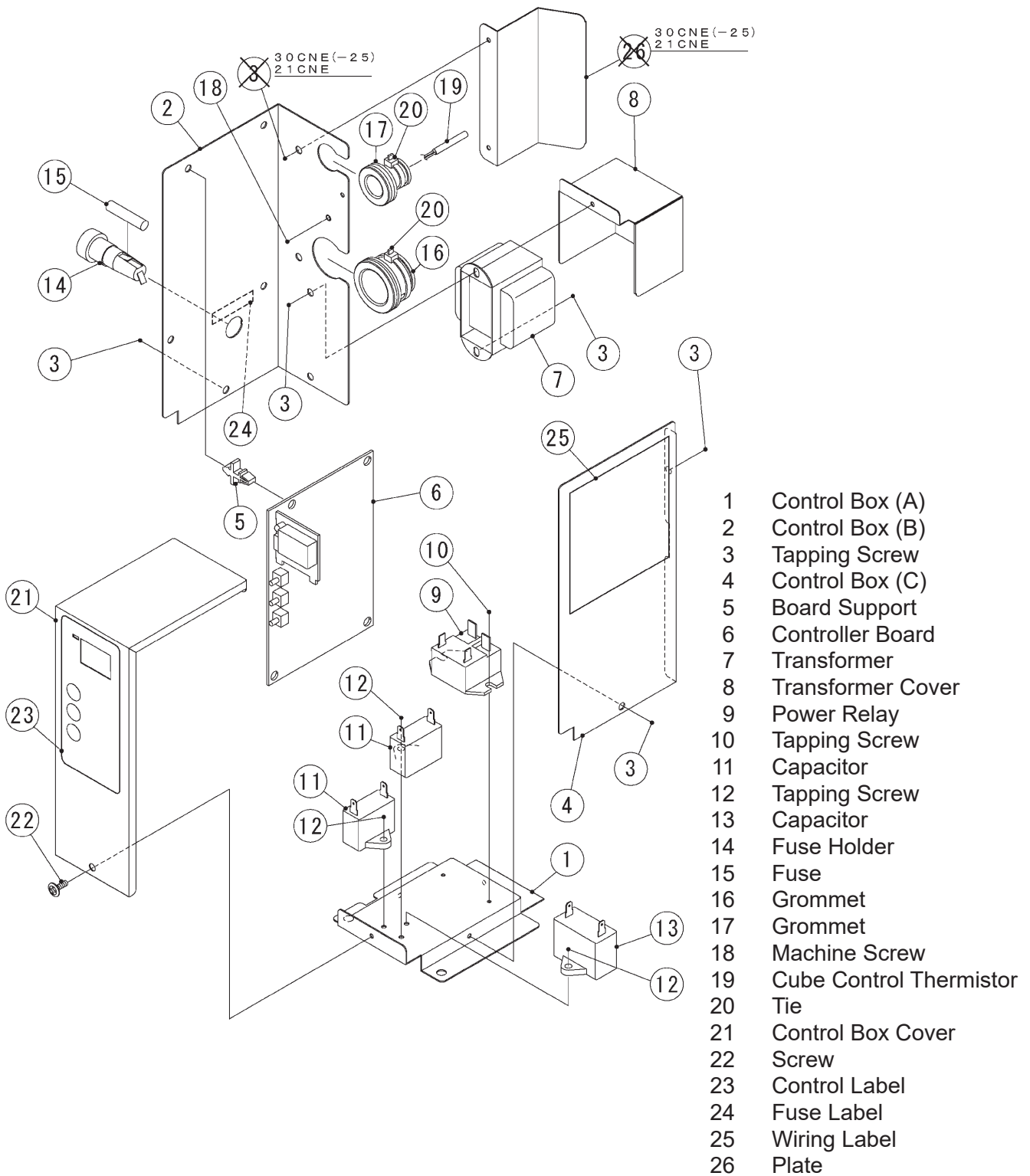
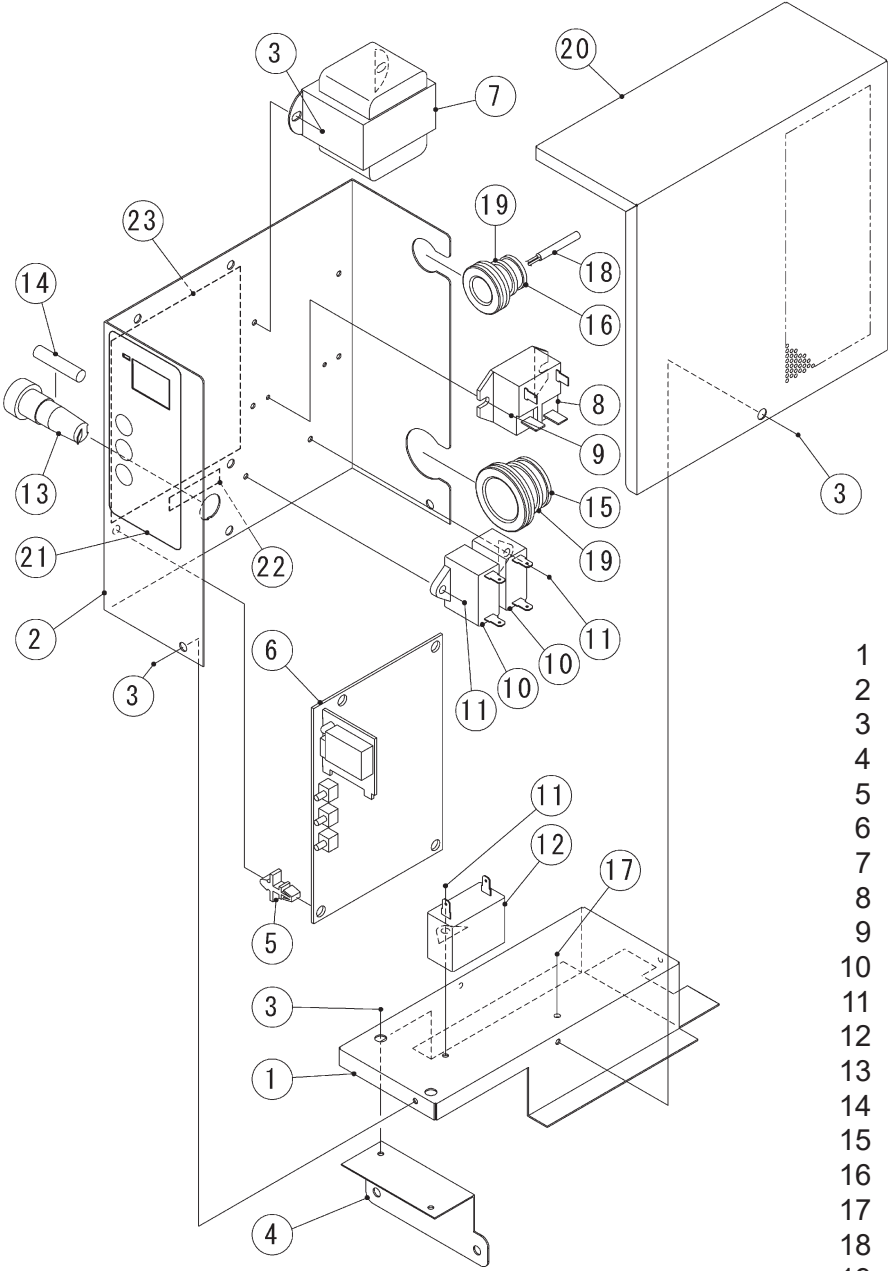

Fig. 18

IM-45CNE/NE/WNE, 65NE/WNE



- 1 Control Box (A)
- 2 Control Box (B)
- 3 Tapping Screw
- 4 Box Plate
- 5 Board Support
- 6 Controller Board
- 7 Transformer
- 8 Power Relay
- 9 Tapping Screw
- 10 Capacitor
- 11 Tapping Screw
- 12 Capacitor
- 13 Fuse Holder
- 14 Fuse
- 15 Grommet
- 16 Grommet
- 17 Machine Screw
- 18 Cube Control Thermistor
- 19 Tie
- 20 Control Box Cover
- 21 Control Label
- 22 Fuse Label
- 23 Wiring Label

Fig. 19

IM-100CNE/NE/WNE, 130NE/WNE

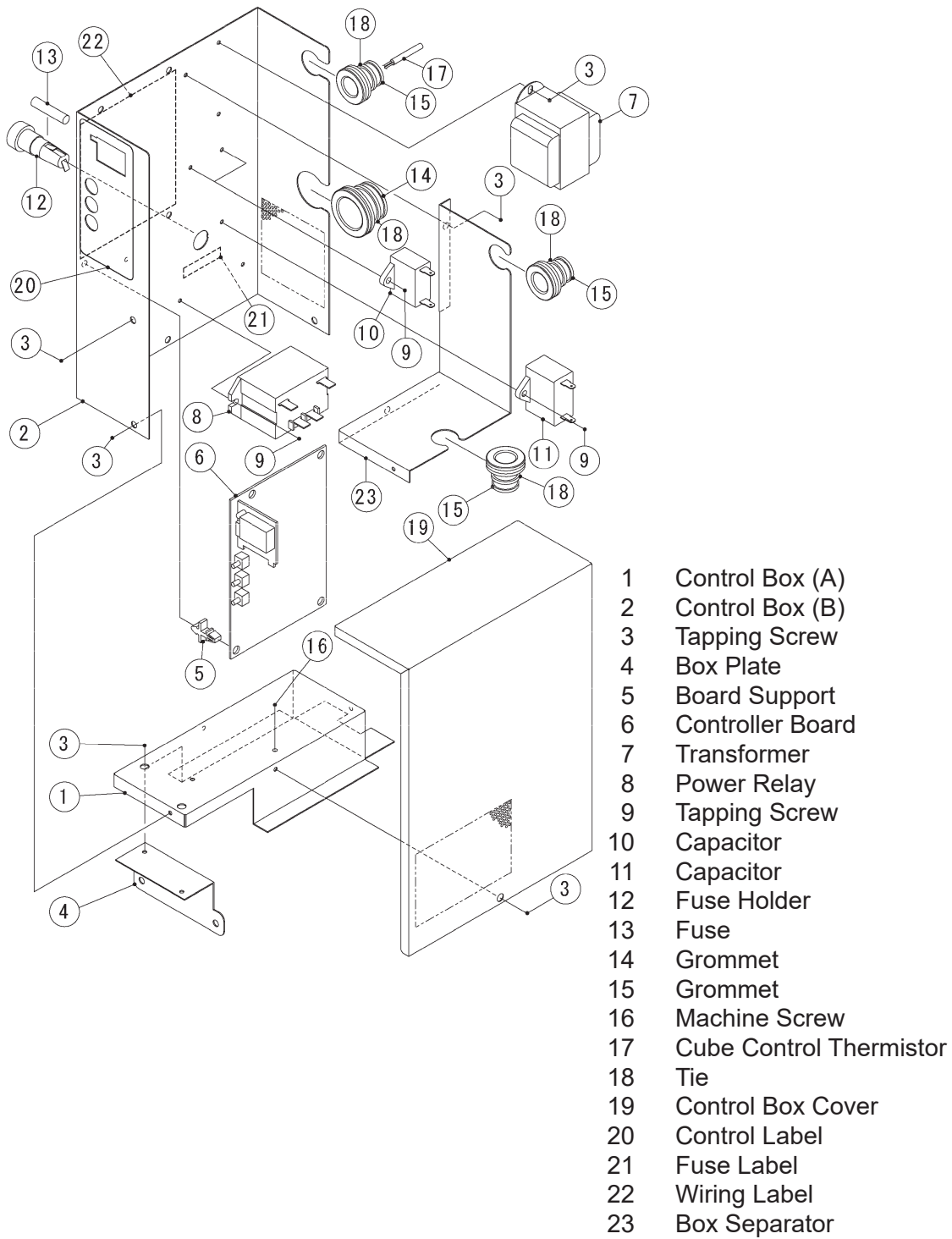
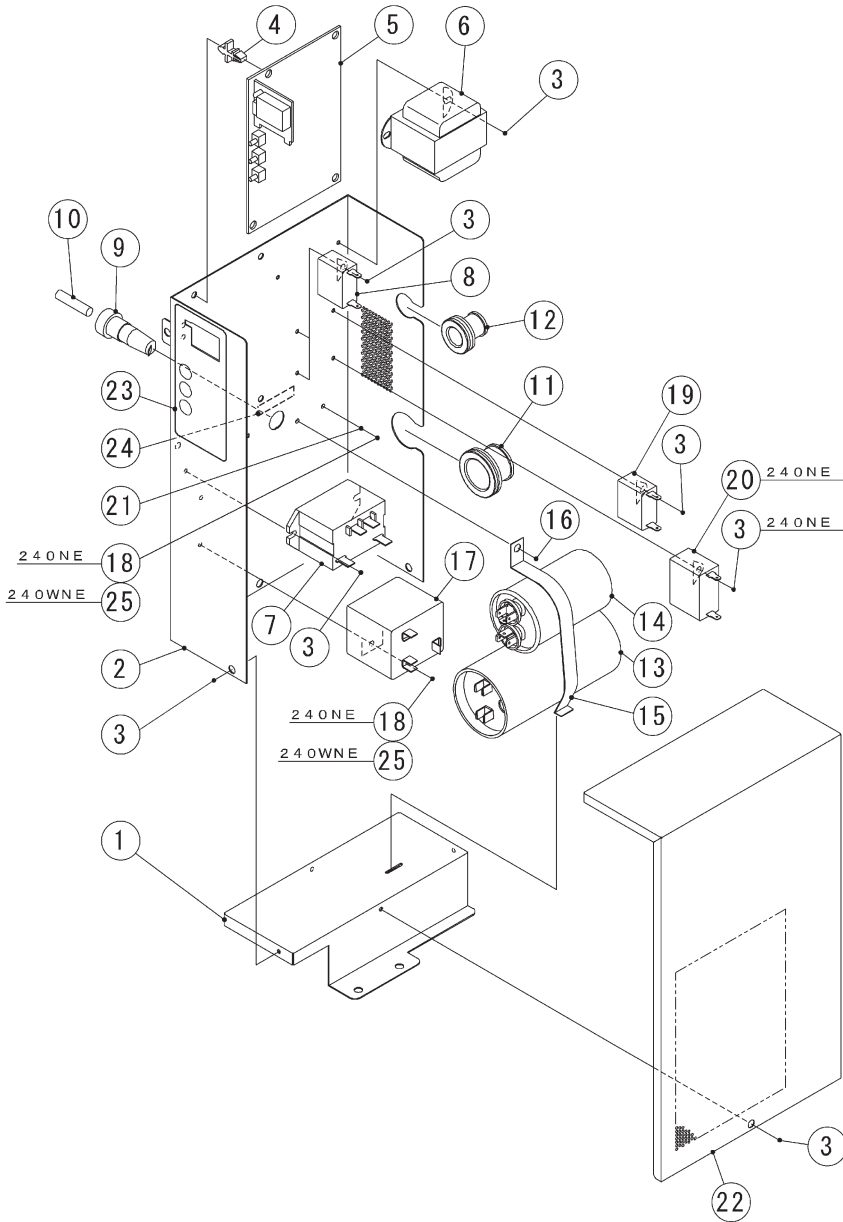

Fig. 20

IM-240NE/WNE



- 1 Control Box (B)
- 2 Control Box - Body (G)
- 3 Tapping Screw
- 4 Board Support
- 5 Controller Board
- 6 Transformer
- 7 Power Relay
- 8 Capacitor
- 9 Fuse Holder
- 10 Fuse
- 11 Grommet
- 12 Grommet
- 13 Start Capacitor
- 14 Run Capacitor
- 15 Band
- 16 Flange Bolt (S-TITE)
- 17 Starter
- 18 Tapping Screw (S-TITE) [IM-240NE]
- 19 Capacitor
- 20 Capacitor [IM-240NE]
- 21 Spring Washer
- 22 Control Box Cover
- 23 Control Label
- 24 Fuse Label
- 25 Machine Screw [IM-240WNE]

Fig. 21

14. THERMISTOR FOR CUBE CONTROL

- 1) Unplug the icemaker or disconnect the power source.
- 2) Remove the top and front panels.
- 3) Remove the connector CN13 on the controller board, referring to “13. CONTROLLER BOARD”.
- 4) Unscrew and remove the thermistor holder and thermistor, located on the evaporator (front side).
- 5) Install the new thermistor in the reverse order of the removal procedure, by using a sealant (high-thermal conduct type). See Fig. 22.

Note: Recommended sealant is KE4560RTV, manufactured by Shin-Etsu Silicones. When other type of sealant used, the cube size and performance will be changed. Do not use silicone sealant as this will insulate the thermistor.

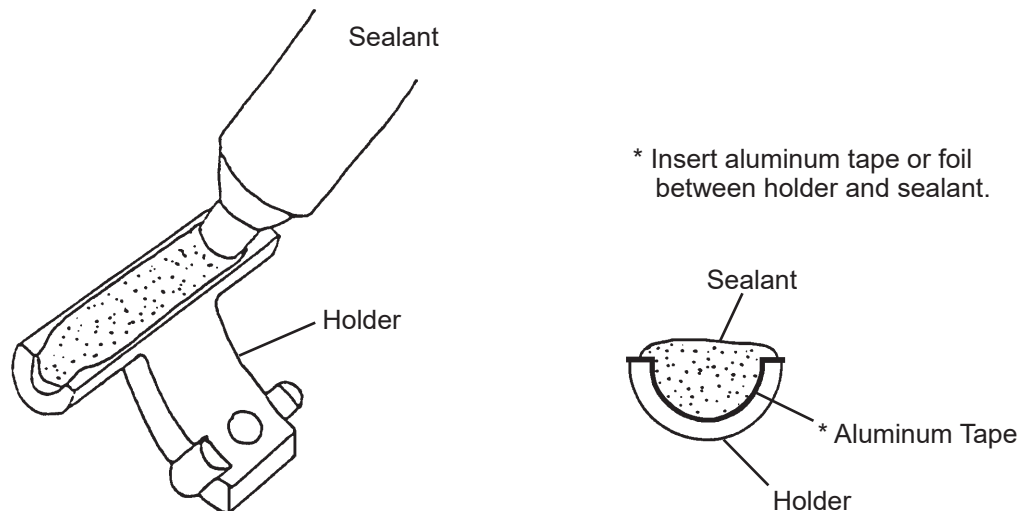

** Thermistor and leads are FRAGILE.
HANDLE WITH CARE.

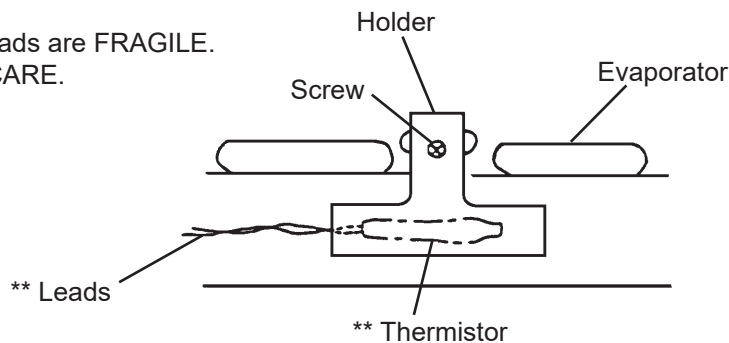

Fig. 22

15. FAN MOTOR - AIR-COOLED MODEL ONLY

- 1) Unplug the icemaker or disconnect the power source.
- 2) Remove the top and rear panels.
- 3) Disconnect the connector of the fan motor.
- 4) Remove the fan motor bracket and the fan motor.
- 5) Cut the leads of the fan motor allowing enough lead length to reconnect using closed end connectors.
- 6) Install the new fan motor in the reverse order of the removal procedure.
- 7) Refit the panels in their correct positions.
- 8) Plug in the icemaker or connect the power source.

16. WATER SUPPLY PIPE

- 1) Unplug the icemaker or disconnect the power source.
- 2) Remove the top panel.
- 3) Remove the screw from the pipe bracket.
- 4) Remove the silicone tube from the water supply pipe.
- 5) Pull the water supply pipe toward you to remove it from the mechanism base.
- 6) Install the new water supply pipe in the reverse order of the removal procedure.
- 7) Replace the top panel in its correct position.
- 8) Plug in the icemaker or connect the power source.

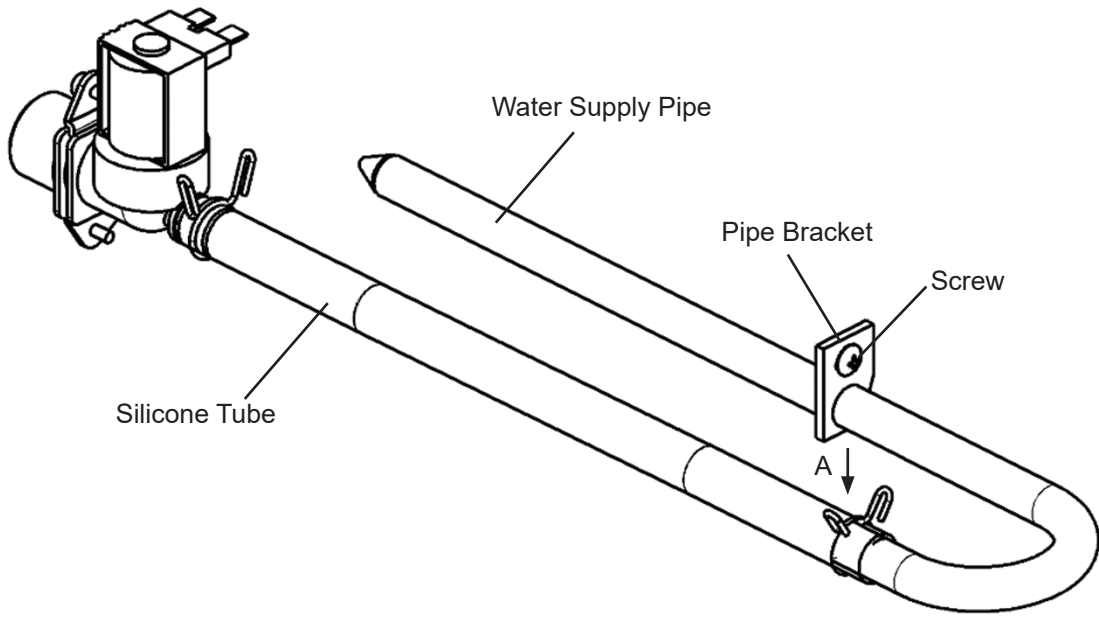

[Installation procedure]

1) Insert the water supply pipe into the hole in the mechanism base.

2) Insert the water supply pipe into the silicone tube by 20 mm.

Note: If the pipe is inserted too much, tensile stress may cause damage to the adhesive joint of the pipe bracket.

3) Secure the pipe bracket to the mechanism base using the screw.

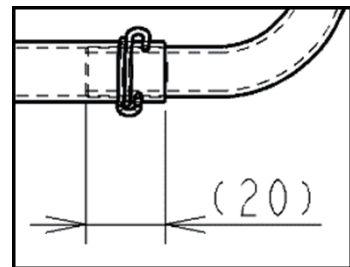

View A

Note: Tighten the screw last to reduce strain stress on the adhesive joint of the pipe bracket.