

1. Install the ice maker properly in accordance with the instructions on location, water supply/drain connections and electrical connections stated in the instruction and installation manuals provided. Allow 10mm extra space at the installation site to meet any installation requirements (additional spacing is also required for proper air flow and pipe connections).
2. The ice production depends on the ambient and water temperatures. Refer to the instruction manual.
3. Values for ice making water only. Use a cooling tower for cooling water.
4. Product Code: E1CL-D020  
(Auxiliary code: C-1 and later)

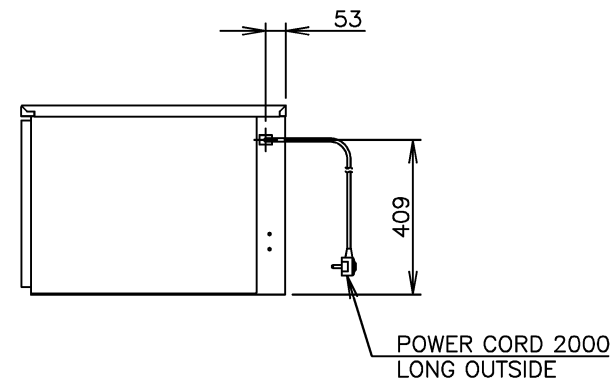
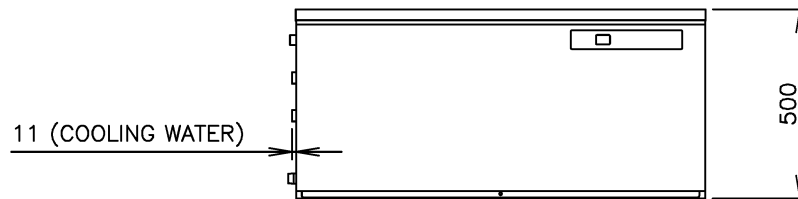
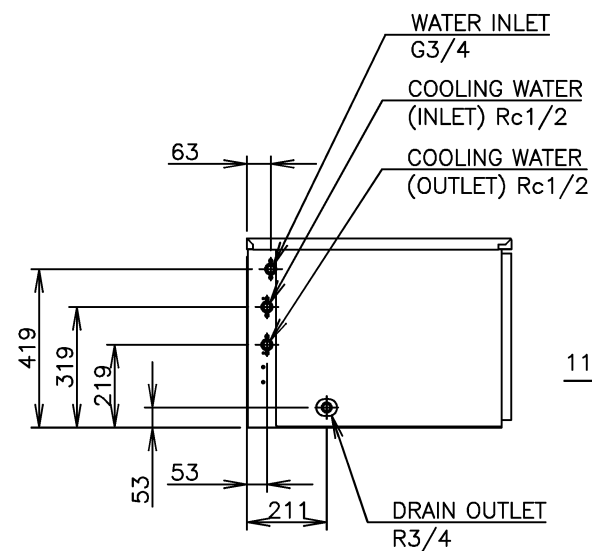
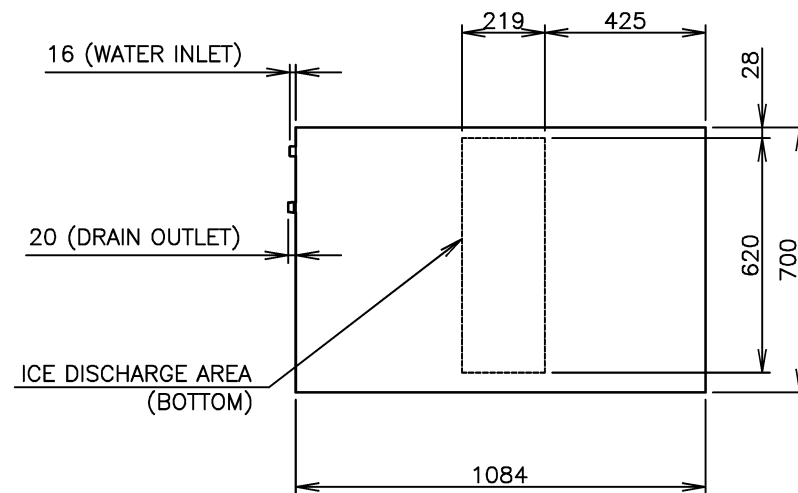

ITEM	Hoshizaki Cube Ice Maker	
MODEL	IM-240DWNE-23	
POWER SUPPLY	1 PHASE 220-230V 60Hz Capacity: Min. 2.9kVA (12.7A)	
AMPERAGE	Running: 5.5A Rated Motor: 5.5A Starting: 46A	
ELECTRIC CONSUMPTION	Rated Motor: 1130W (Power factor: 89%)	
ICE PRODUCTION PER 24h	Approx. 190 (5mm) / 220 (15mm) kg (Ambient Temp.10° C, Water Temp.10° C) Approx. 185 (5mm) / 200 (15mm) kg (Ambient Temp.21° C, Water Temp.15° C) Approx. 175 (5mm) / 190 (15mm) kg (Ambient Temp.32° C, Water Temp.21° C)	
WATER CONSUMPTION PER 24h *3	Approx. 0.84m <sup>3</sup> (Ambient Temp.10° C, Water Temp.10° C) Approx. 0.43m <sup>3</sup> (Ambient Temp.21° C, Water Temp.15° C) Approx. 0.40m <sup>3</sup> (Ambient Temp.32° C, Water Temp.21° C)	
SHAPE OF ICE	Cube Approx. 28x28x23mm	
FREEZE CYCLE TIME	Approx. 16min (5mm) (Ambient Temp.21° C, Water Temp.15° C)	
ICE PRODUCTION PER CYCLE	Approx. 2.38kg / 140pcs. (5mm) (Ambient Temp.21° C, Water Temp.15° C)	
OUTSIDE DIMENSIONS	1084mm(W)x700mm(D)x500mm(H)	
EXTERIOR	Stainless Steel	
CONNECTIONS-ELECTRIC	X-Type Con. (with CONT. Plug)	
CONNECTIONS-WATER SUPPLY	Inlet G3/4 (connected at left side)	
CONNECTIONS-DRAIN	Outlet R3/4 (connected at left side)	
CONNECTIONS-COOLING WATER	Inlet Rc1/2 (connected at left side) Outlet Rc1/2 (connected at left side)	
ICE MAKING SYSTEM	Cell type	
HARVESTING SYSTEM	Hot Gas Defrost	
COMPRESSOR	Hermetic	
CONDENSER	Water-Cooled, Tube in Tube type	
HEAT REJECTION	2385W (2050kcal/h) (Ambient Temp.32° C, Water Temp.21° C)	
EVAPORATOR	Tin-plated Copper Tube on Sheet and Cells	
REFRIGERANT CONTROL	Thermostatic Expansion Valve	
REFRIGERANT CHARGE	R404A/400g	
ICE MAKING CONTROL	Thermistor, Timer	Controller Board
HARVESTING CONTROL	Thermistor	
BIN CONTROL	Microswitch with Time Delay	
ICE MAKING WATER CONTROL	Timer, Water Pan's movement	
ELECTRICAL PROTECTION	Class I Appliance, 5A Fuse	
COMPRESSOR PROTECTION	Auto-reset Overload Protector	
ICE MAKER PROTECTION	Interlock by Controller Board	
NET WEIGHT	87kg (Gross 100kg)	
PACKAGE	Carton 1196mm(W)x825mm(D)x640mm(H)	
ACCESSORIES	Scoop, Installation Kit, Brace	
OPERATING CONDITIONS	Ambient Temp.: 1 - 40° C, Water Supply Temp.: 5-35° C Water Supply Pressure: 0.07-0.8MPa (0.7-8bar) Voltage Range: Rated Voltage±10%	

\*We reserve the right to make changes in specifications and design without prior notice.

# HOSHIZAKI CUBE ICE MAKER IM-240DWNE-23

APPROVED M.NOTSU	CHECKED MIYAZAKI	DESIGNED ISHITOMI	DRAWN A.KOBAYASHI	SCALE 1/20	TRIGONOMETRY
YAMASAKI	ISHITOMI	2016.08.10	DATE 2013.10.29	DRAWING NO. D13613	SYMBOL ⚠
APPROVED	DESIGNED	SYMBOL	DATE		